

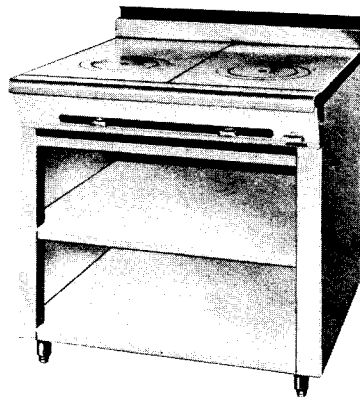

Model 136-9A

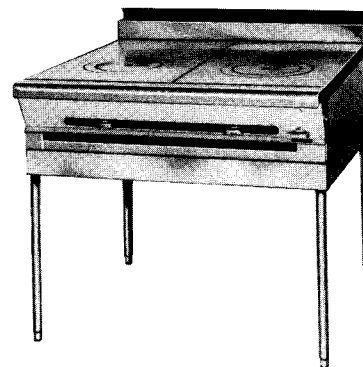

Model 36-9A



Model M36-9A

Model Variations:

136-9A — Oven model with 6" legs.

36-9A — Cabinet model with 6" legs.

M36-9A — Countertop model with 28" high modular stand with S/S tubular legs.

C36-9A — Counter model

(French-Type) Hot Tops: Two 18" wide x 31" deep cast iron Hot Tops with ring and cover. Each section is front fired with one Banjo-type burner rated at 35,000 BTU/HR. Constructed with specially designed conduction studs for improved heat transfer and 2" integral flanges on front and sides. Fire brick along the bottom of flue slopes upward toward rear vent. High temperature commercial-type burner valves and constant burning pilots are used for automatic lighting. An insulated partition to confine heat to each individual top configuration is furnished.

Oven Interior: The front venting oven is 26" wide x 28" deep x 15" high. Standard interior finish is porcelainized steel. Options, *(extra cost):

*Cast iron oven bottom

The 3-position rack guides and oven bottom are removable for major cleaning. The oven is heated by a cast iron burner rated at 40,000 BTU/HR. The oven cavity is completely encased in high density fiberglass insulation maximizing heat retention. One rack with bright nickel finish is furnished.

Oven Controls: Includes manual burner valve, heavy duty throttling type thermostat, 100% safety pilot and automatic lighting. Controls are located in an insulated and vented compartment for longer life. Thermostat located on front right side. Thermostat dial has a temperature range from low to 500°F (260°C).

Oven Doors: Weight counterbalanced without the use of springs. One piece offset tubular-type handle is used.

Finish: Satin finish stainless steel front, including 4" flue riser. Remaining exterior black. All painted surfaces have electrolytic zinc undercoating for corrosion protection and longer life. Additional S/S finish available, *(extra cost):

*S/S left side *S/S right side *S/S back panel
 *S/S lower shelves for cabinet base, (2 ea. required)
 NOTE: Black finish with S/S trim available.

Options, *(extra cost):

- | | S/S front | Black |
|---|--------------------------|--------------------------|
| <input type="checkbox"/> *18" High Back: | <input type="checkbox"/> | <input type="checkbox"/> |
| <input type="checkbox"/> *Single High Shelf: | <input type="checkbox"/> | <input type="checkbox"/> |
| <input type="checkbox"/> *Double High Shelf: | <input type="checkbox"/> | <input type="checkbox"/> |
| <input type="checkbox"/> *Doors for Cabinet Base: | <input type="checkbox"/> | <input type="checkbox"/> |
| <input type="checkbox"/> *Extra Oven Racks | | |
| <input type="checkbox"/> *42" Range Depth, suffix -40 | | |
| <input type="checkbox"/> *Left Rear Manifold with pressure regulator: | | |
| <input type="checkbox"/> *3/4" NPT, up to 165,000 BTU/HR | | |
| <input type="checkbox"/> *3/4" NPT, up to 320,000 BTU/HR | | |
| <input type="checkbox"/> * 1" NPT, up to 500,000 BTU/HR | | |
| <input type="checkbox"/> Cap, Manifold: <input type="checkbox"/> left side <input type="checkbox"/> right side | | |
| (Must specify when ordering.) | | |
| <input type="checkbox"/> *S/S Cover, Manifold: <input type="checkbox"/> left side <input type="checkbox"/> right side | | |
| <input type="checkbox"/> *Plate Shelf — 6" wide, S/S | | |
| <input type="checkbox"/> *Casters — set of 4, 5" wheel, 6" height | | |
| <input type="checkbox"/> *Flex Connector Kit — hose, disconnect and restraining device: <input type="checkbox"/> *3' x 3/4" <input type="checkbox"/> *4' x 3/4" <input type="checkbox"/> *5' x 3/4" | | |
| <input type="checkbox"/> *Security Options — i.e., prisons. Consult factory. | | |

Exterior Dimensions: 36" wide x 36-5/8" deep. See drawing on reverse side for heights. For 42" depth add 6" to overall depth of range.



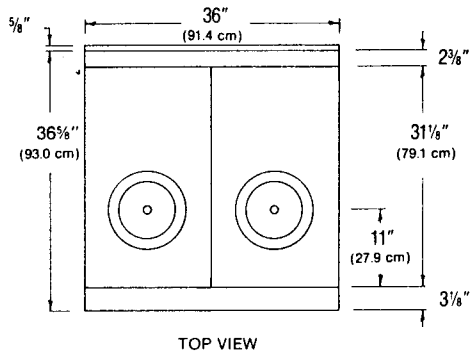

TOP VIEW

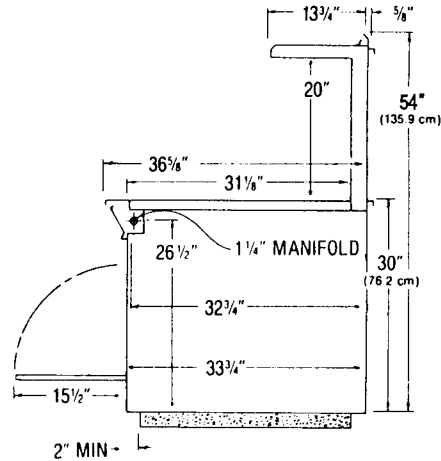

SIDE VIEW WITH SINGLE HIGH SHELF AND CURB MOUNT

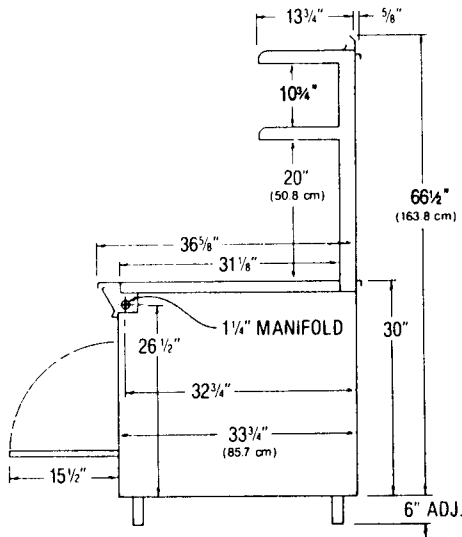

SIDE VIEW WITH DOUBLE HIGH SHELF AND ADJUSTABLE LEGS

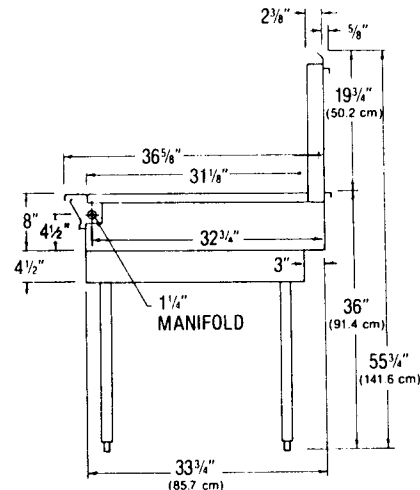

SIDE VIEW MODULAR MODEL WITH HIGH BACK

IMPORTANT:

Ranges must be installed in accordance with local codes or, in the absence of local codes, with the National Fuel Gas Code ANSI Z223.1. Compliance with codes is the responsibility of the Owner and Installer.

Adequate Ventilation System required. Refer to the National Fire Protection Association Standard No.96, "Vapor Removal from Cooking Equipment".

AGA Design Certified: in accordance with ANSI Z83.11 Gas Foodservice Equipment — Ranges. (Note: These appliances are intended for commercial use by professionally trained personnel. *NOT Intended For Household Use.*)

Minimum Clearances:	Combustible Construction	Noncombustible Construction
Back Wall:	2"	0"
Left & Right Side:	6"	0"
With 6" legs: suitable for installation on combustible floors.		
Without legs: For use only on noncombustible floors.		
Counter models: For use on noncombustible counters only.		

TYPE OF GAS		Natural 4.0" WC	Propane 10" WC
Model	# burners	BTU/HR	BTU/HR
136-9A	3	110,000	110,000
36-9A	2	70,000	70,000
C36-9A	2	70,000	70,000
M36-9A	2	70,000	70,000

GAS INLET SIZE (for all models):

1-1/4" front manifold with 1/2 union on each end provided for battery connection. Properly sized gas pressure regulator must be *Furnished By The Installer.*

Note: Specify type of gas Natural Propane
Specify elevation if installing above 2000 feet.

SHIPPING WEIGHT: *Class 77-1/2 **Class 85
136-9A *616 lbs. C36-9A **340 lbs.
36-9A **430 lbs. M36-9A **360 lbs.

ENTRY CLEARANCE: 30", all models, uncrated.

APPROX. CUBIC FT., (crated):

Cabinet base models. . . 27 Counter Models. . . 13

Montague's sole commitment to quality/product improvement can cause specification and design changes without prior notice.

