

# INSTRUCTION MANUAL

## MONTAGUE LEGEND

### Radiglo Heavy Duty Gas Fired Over Fired Broilers



**MODELS: 36W36, 43W36, 136W36, V136W36, 236W36, 243W36, C36,  
C45, C36 SHB, C45 SHB, C36SHBPL, C45SHBPL**

**These instructions should be read thoroughly before attempting installation.  
Set up and installation should be performed by qualified installation personnel.**

**Keep area around appliances free and clear from combustibles.**

**PLEASE RETAIN THIS MANUAL  
FOR FUTURE REFERENCE.**



**THE MONTAGUE COMPANY**

1830 Stearman Avenue

P.O. BOX 4954

Hayward, CA 94540-4954

TEL: (510) 785-8822 FAX: (510) 785-3342

# IMPORTANT

## TABLE OF CONTENTS

<b>Important (Cautions and Warnings)</b> .....	<b>Page 1</b>
<b>Introduction</b> .....	<b>Page 2 - 3</b>
<b>Installation</b> .....	<b>Page 4 - 10</b>
<b>Operation</b> .....	<b>Page 11 - 12</b>
<b>Maintenance</b> .....	<b>Page 13 - 15</b>
<b>Maintenance Schedule</b> .....	<b>Page 16</b>
<b>Service</b> .....	<b>Page 17 - 27</b>
<b>Orifice Size Chart - Drill Size</b> .....	<b>Page 28</b>
<b>Exploded View and Parts List</b> .....	<b>Page 29 - 32</b>

---

## SHIPPING DAMAGE CLAIM PROCEDURE

For your protection, please note that equipment in this shipment was carefully inspected and packed by skilled personnel before leaving the factory. The transportation company assumed full responsibility for safe delivery upon acceptance of this shipment.

### **If shipment arrives damaged:**

1. **VISIBLE LOSS OR DAMAGE** - Be certain this is noted on freight bill or express receipt, and signed by person making delivery.
2. **FILE CLAIM FOR DAMAGES IMMEDIATELY** - Regardless of the extent of damage.
3. **CONCEALED LOSS OR DAMAGE** - If damage is unnoticed until merchandise is unpacked, notify transportation company or carrier immediately, and file "concealed damage" claim with them. This should be done within fifteen (15) days of date that delivery was made to you. Be sure to retain container for inspection.

*We cannot assume responsibility for damage incurred in transit. We will, however, be glad to furnish you with the necessary documents to support your claim.*

# IMPORTANT

## FOR YOUR SAFETY



### **WARNING**

Improper installation, adjustment, alteration, service or maintenance can cause property damage, injury or death. Read the operating and maintenance instructions thoroughly before installing or servicing this equipment.



### **WARNING**

Do not store or use gasoline or other flammable vapors and liquids in the vicinity of this or any other appliance.

**NOTE:** This manual has been prepared for personnel qualified to install commercial equipment who should perform the initial field start-up and the adjustments of the equipment covered by this manual.

**NOTE:** Instructions to be followed in the event the user smells gas must be posted in a prominent location. This information may be obtained by consulting the local gas supplier.

# INTRODUCTION

## GENERAL

The Gas Broilers covered in this manual are manufactured for use with the type of gas indicated on the nameplate. Some models include a cabinet, conventional oven, or convection oven.

Montague Gas Broilers are produced with the best possible material and workmanship. Proper installation is essential for safe, efficient, trouble-free operation.

## MODELS

Model	Features
36W36	Cabinet Based Broiler with Warming Oven
43W36	Cabinet Based Broiler with Warming Oven
136W36	Broiler with Conventional Oven and Warming Oven
V136W36	Broiler with Convection Oven
236W36	Double Broiler
243W36	Double Broiler
C36	Broiler Only
C45	Broiler Only

## SERIAL NUMBER LOCATION

Always have the serial number of your unit available when calling for parts and service. The serial number is on the nameplate that also includes the model number. A typical identification plate is shown in Figure 1.

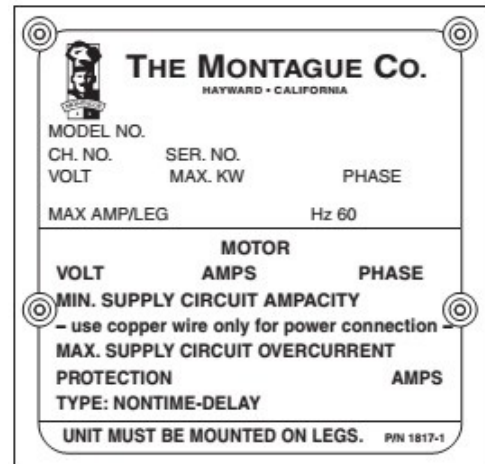

Typical I.D. Plate  
(Figure 1)

## RECEIVING & INSPECTING THE EQUIPMENT

Care should be taken during unloading so the equipment is not damaged while being moved into the building.

1. Visually inspect the exterior of the package and skid or container. Any damage should be noted and reported to the delivering carrier immediately.
2. If damaged, open and inspect the contents with the carrier.
3. In the event that the exterior is not damaged, yet upon opening, there is concealed damage to the equipment, notify the carrier. Notification should be made verbally as well as in written form.
4. Request an inspection by the shipping company of the damaged equipment. This should be done within 10 days from receipt of the equipment.
5. Freight carriers can supply the necessary damage forms upon request.
6. Retain all shipping materials until an inspection has been made or waived.

# INTRODUCTION

## ORIFICES

Fixed for specified Gas type:

Natural Gas: #33 DMS

Propan Gas: #48 DMS

<b>Manifold Pressure</b>	
Natural Gas	Propane Gas
6" W.C.	10" W.C.
Gas Inlet Size: 3/4" NPT at lower left rear (all models).	

<b>Model</b>	<b># Burners (Broilers Only)</b>	<b>Natural BTU/h</b>	<b>Propone BTU/h</b>	<b>Total BTU/h</b>
36W36	2	42,000 ea.	42,000 ea.	84,000
43W36	3	42,000 ea.	42,000 ea.	126,000
136W36	2	42,000 ea.	42,000 ea.	124,000
V136W36	2	42,000 ea.	42,000 ea.	129,000
236W36	4	42,000 ea.	42,000 ea.	168,000
243W36	6	42,000 ea.	42,000 ea.	252,000
C36	2	42,000 ea.	42,000 ea.	84,000
C45	3	42,000 ea.	42,000 ea.	126,000

# INSTALLATION

This manual has been prepared for personnel qualified to install gas equipment, who should perform the initial field start-up and adjustments of the equipment covered by this manual.

Qualified installation personnel are individuals, a firm, corporation, or company which either in person or through a representative are engaged in and are responsible for:

1. The installation or replacement of gas piping or the connection, installation, repair or servicing of equipment, who is experienced in such work familiar with all precautions required, and have complied with all requirements of state or local authorities having jurisdiction. reference: National Fuel Gas Code, ANSI Z223.1, section 1.4, latest addenda.
2. The installation of electrical wiring from the electric meter, main control box or service outlet to the electric appliance. Qualified installation personnel must be experienced in such work, be familiar with all precautions required and have complied with all requirements of state and local authorities having jurisdiction. Reference: National Electric Code, ANSI / NFPA No. 70, latest addenda.

## READ CAREFULLY AND FOLLOW THESE INSTRUCTIONS

The broiler(s) must be installed in accordance with local codes, or in the absence of local codes, with the national fuel gas code, ANSI Z223.1 latest addenda, including:

1. The appliance and its individual shutoff valve must be disconnected from the gas supply piping system during any pressure testing of that system at test pressures in excess of 1/2 psig (3.45 kpa).
2. The appliance must be isolated from the gas supply piping system by closing its

individual manual shutoff valve during any pressure testing of the gas supply piping system at test pressures equal to or less than 1/2 psig (3.45 kpa).

Post in a prominent location the instructions to be followed in the event the smell of gas is detected. This information can be obtained from the local gas supplier.

In the event of a power failure, do not attempt to operate this device.



### IMPORTANT

**IN THE EVENT A GAS ODOR IS DETECTED, SHUT DOWN UNITS AT MAIN SHUTOFF VALVE AND CONTACT THE LOCAL GAS COMPANY OR GAS SUPPLIER FOR SERVICE.**



### CAUTION

**PROVISIONS MUST BE MADE TO ASSURE ADEQUATE AIR SUPPLY TO UNIT FOR PROPER BURNER OPERATION.**

## CLEARANCES

The following are minimum clearances from combustible and noncombustible materials.

Location	Combustible Construction	Noncombustible Construction
Back Wall	6"	0"
Left Side	6"	0"
Right Side	6"	0"

With 6" Legs: Suitable for installation on combustible floors.

Without Legs: For use with special insulated base on noncombustible floors only.

# INSTALLATION

## VENTILATING HOOD

The broiler(s) must be installed under a properly designed ventilating hood. The hood should extend at least 6" beyond all sides of the unit. The hood should be connected to an adequate mechanical exhaust system.

Information on construction and installation of ventilating hoods may be obtained from the "Standard for the Installation of Equipment for the Removal of Smoke and Grease Laden Vapors from Commercial Cooking Equipment", NFPA No. 96-1987, available from the National Fire Protection Association, Batterymarch Park, Quincy, MA. 02269.

It is also necessary that sufficient room air ingress be allowed to compensate for the amount of air removed by the ventilating system. Otherwise, a subnormal atmospheric pressure will occur which may interfere with burner performance or may extinguish the pilot flame. In case of unsatisfactory broiler performance, check with the exhaust in the "OFF" position.

## ASSEMBLY

Uncrate broiler as near to final location as possible. For easier and lighter handling of broiler, remove grids, grid frame, drip tray and grease container. Remove all packing materials and accessories from broiler interior.

### Legs

Some broilers are mounted on legs.

Screw the legs into the modular stand.

Tightly screw the complete leg assembly into the mounting holes in the bottom of the broiler at each corner. If the unit is intended for curb installation, no legs are provided. The curb must be noncombustible material.

### Ceramic Radiants

Ceramic radiants, Figure 1 & 2, are located on each side of the burners. Ceramic end pieces are installed at both ends of each burner assembly. Five (5) ceramic radiants are installed on each side of each burner with the pointed side facing down and the holes facing up (See Figure 3).

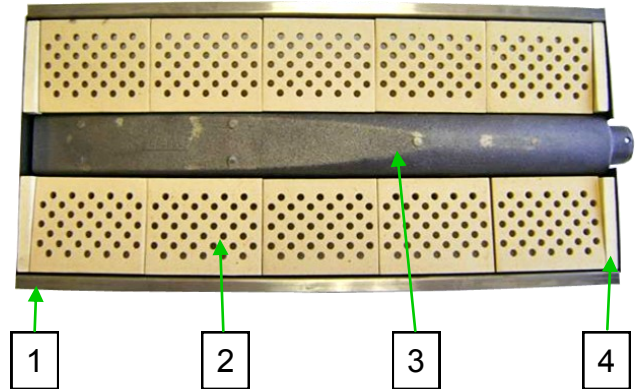

1	Frame
2	Ceramic Radiants
3	Burner
4	Ceramic Ends

Burner Assembly and Ceramic Radiants, Top View (Figure 1)



Burner Assembly and Ceramic Radiants, Front View (Figure 2)

# INSTALLATION

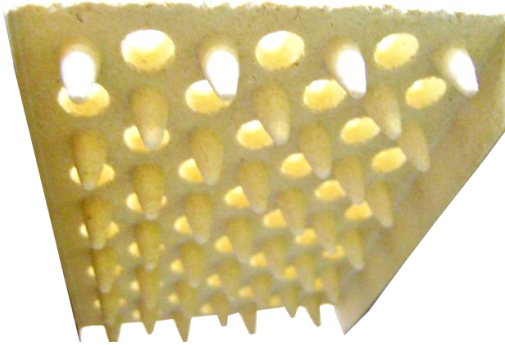

Ceramic Radiant  
(Figure 3)

1. Insert ceramic end pieces at front and rear of the burner frame. Four (4) are required for each burner.
2. Tilt ceramic radiants sideways to clear burner and frame assembly, then lower radiant into position with one flange resting on burner ledge and one flange resting on frame edge.
3. Install the remaining ceramic radiants so that five (5) ceramic radiants are located on each side of the burner.

## LOCATION

Adequate clearance for service and proper operation must be provided at the front, top, sides, and back. The combustion air openings are provided in the front of the unit and must not be obstructed.

## LEVELING

After broiler is positioned, check that appliance is level both side-to side and front-to back.

## BATTERY ARRANGEMENT

### Setting In Place

Model No's 36W36, 43W36, 136W36, and V136W36.

## Floor Mounted Ranges

1. Place the first unit in the exact position it will occupy in the battery.
2. Using a carpenter's level, level the unit front to rear and side to side. **An unlevelled unit will adversely affect performance.** Adjust as follows:

## FLOOR INSTALLATION ON LEGS

Level by turning foot on leg.

## CURB INSTALLATION

Place shim under the low side. This operation is important since variations in floors and curbs are common. Unless units are level, aligning the gas supply manifold will be difficult and the units will not fit together tightly.

3. Remove the valve panel from the broiler.
4. Move the unit into position.
5. Engage union nut on manifold with male fitting on next unit and draw up union nut hand tight. Be sure appliances meet together both front and rear. If manifolds do not align, then units are not level. In extreme cases it may be necessary to loosen manifold bolts and adjust.
6. Continue leveling and connecting gas supply manifolds together until all appliances in battery are connected.
7. Tighten manifold gas union. Use backup wrench to prevent manifold from rotating. **Failure to do this may result in damage to the pilots and gas valves.**

## GAS CONNECTION

Before connecting the broiler(s) to the gas supply line, be sure that all new piping has been cleaned and purged to prevent any foreign matter from being carried into the controls by the gas. In some cases, filters

# INSTALLATION

or drops are recommended. A separate gas shutoff valve must be installed upstream from the gas pressure regulator adjacent to the broiler and located in an accessible area.

It is important that adequately sized piping be run directly to the point of connection at the broiler with as few elbows and tees as possible. Consult your local gas company for proper piping size and gas pressure. Each broiler has a 3/4" NPT manifold input located at the lower left rear of the broiler, Figure 4. On dual broilers, each broiler must have a separate regulator.

**NOTE:** Pipe joint compound or thread sealant that is used should be resistant to action of liquefied petroleum gases.



3/4" NPT Gas Inlet

Gas Inlet  
(Figure 4)

Install the gas pressure regulator with gas flowing as indicated by the arrow on the regulator. The arrow must be pointing in toward the unit. Use pipe compound or thread sealant and carefully thread regulator to pipe so that there is no cross threading, etc., which could cause leakage.

1. Apply wrench only to the flat areas around the pipe tapping at the end being threaded to the pipe to avoid possible damage to the

regulator body which could result in leakage.

2. Connect the gas supply line from the service gas shutoff valve to the inlet side of the gas pressure regulator using 3/4" pipe. Avoid kinks or sharp bends that could restrict gas flow.

**NOTE:** If flexible or semi-flexible connectors are used, an AGA listed flexible connector with an I.D. equal to 3/4" pipe must be used.



## WARNING

**DO NOT USE A DOMESTIC TYPE FLEXIBLE GAS CONNECTOR.**

3. Turn gas shutoff valve on and carefully check for gas leaks immediately. Do this before attempting to operate the broiler.



## WARNING

**TEST ALL PIPE JOINTS FOR LEAKS BEFORE OPERATING BROILER. THIS INCLUDES ALL GAS CONNECTIONS THAT MAY HAVE LOOSENED DURING SHIPMENT. USE A RICH SOAP SOLUTION (OR OTHER ACCEPTED LEAK TESTER) AROUND ALL PIPE JOINTS. DO NOT USE AN OPEN FLAME. ABSOLUTELY NO LEAKAGE SHOULD OCCUR, OTHERWISE THERE IS A DANGER OF FIRE OR EXPLOSION DEPENDING UPON CONDITIONS. DO NOT USE UNIT IF LEAKAGE IS DETECTED.**

After piping has been checked for leaks, all piping receiving gas should be fully purged to remove air.

## GAS PRESSURE REGULATOR



## WARNING

**DO NOT INSTALL UNIT WITHOUT AN APPLIANCE REGULATOR.**

# INSTALLATION

**THE BROILER IS DESIGNED FOR USE WITH A PRESSURE REGULATOR. THE REGULATOR(S) SUPPLIED WITH THIS UNIT MUST BE USED.**

## For Natural Gas

This gas pressure regulator is factory adjusted for 6.0" W.C. manifold pressure. The rated inlet pressure to the regulators should not exceed 1/2 psig (3.45 kPa).

## For Propane Gas

This gas pressure regulator is factory adjusted for 10.0" W.C. manifold pressure. The rated inlet pressure to the regulator should not exceed 1/2 psig (3.45 kPa).

The broiler is equipped with fixed orifices for use with a manifold pressure of 6.0" W.C. for natural gas and 10.0" W.C. for propane gas.

Position the gas pressure regulator outside the broiler as near to the unit as possible.

### CAUTION

**THE GAS PRESSURE REGULATOR MUST BE LOCATED OUT OF THE HEAT ZONE TO PREVENT DAMAGE TO THE REGULATOR.**

### ADJUSTMENT PROCEDURE

### WARNING

**DO NOT ALLOW UNTRAINED PERSONNEL TO MAINTAIN OR SERVICE THE GAS PRESSURE REGULATOR.**

1. Before adjusting the regulator, check the incoming gas line pressure into the regulator. Incoming pressure must be 8.0" W.C. for natural gas, or 14" W.C. for propane gas.
2. If incoming pressure is not correct, have the gas source checked and adjusted.

3. Make sure that the regulator is mounted in the horizontal position with the arrow going in the direction of the gas flow.
4. Remove the main burner control valve knobs, Figure 5.

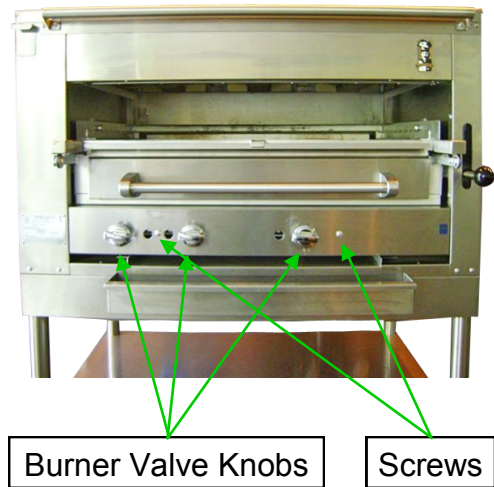

Control Valve Knobs  
(Figure 5)

5. Remove the control valve panel by removing two screws.
6. Connect a manometer to the pressure tap provided on the broiler unit gas piping manifold, Figure 6.
7. Check the manometer reading. The reading must be 6.0" W.C. for natural gas, or 10.0" W.C. for propane gas. (DYNAMIC)
8. If incoming line pressure is not correct, adjust the regulator. Remove the seal cap on the top of the regulator.
9. Insert a slot screwdriver into the top of the regulator.
10. Turn the adjust screw clockwise to increase the pressure, or counter clockwise to decrease the pressure.

While watching the manometer, turn the adjustment screw to set proper regulator outlet pressure to the manifold.

# INSTALLATION

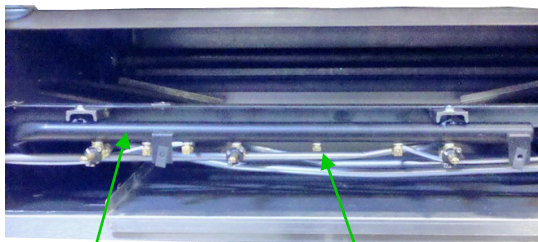

Manifold  
Manometer  
Connection Pressure  
Tap

Gas Pressure Tap  
(Figure 6)

## PILOT INITIAL ADJUSTMENT

Each burner has a separate pilot burner. The pilot flame is adjusted through access holes in the valve control panel, Figure 7. Pilot access is through the broiler panel opening.

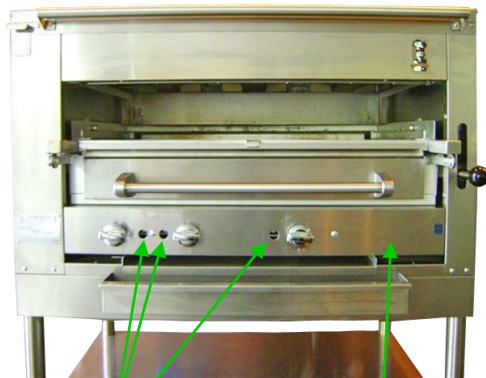

Pilot Valves  
Valve Panel

Pilot Valves  
(Figure 7)

1. Turn the main gas shutoff valve to the on position.

**NOTE:** Pilots are on at all times if main shutoff valve is in the on position and pilot adjustment valves are open.

2. Light each pilot.

3. Adjust pilot valve adjustment screw so that each pilot burner has a steady blue flame, Figure 8.

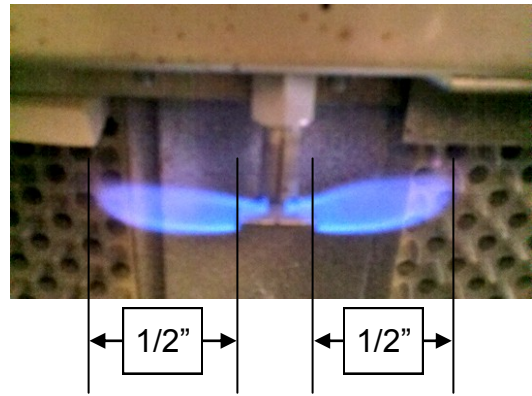

Pilot Burner  
(Figure 8)

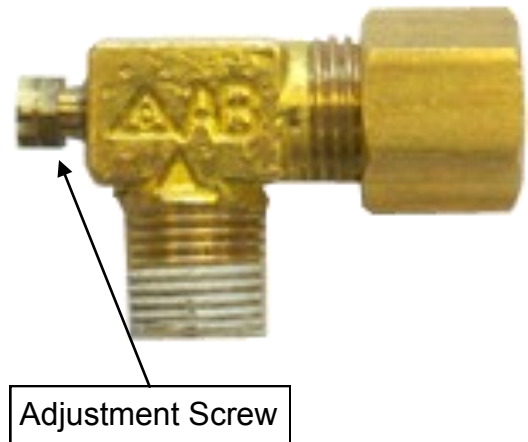

Adjustment Screw

Pilot Valve  
(Figure 9)

## BURNER ADJUSTMENT

The efficiency of the broiler depends on a delicate balance between the supply of air and the volume of gas at each main burner resulting in complete combustion. Whenever this balance is disturbed, poor operating characteristics occur. An air shutter, Figure 9, on the front of each main burner controls the air supply.

# INSTALLATION

**NOTE:** Pilots should be lit and properly adjusted before adjusting the main burners.

1. Lift off the manifold cover to access the air shutter for each main burner.
2. Turn main burner control valve on fully, (counterclockwise) in order to adjust burner flame.
3. Increase the air shutter openings until the flame on the burner begins to “lift”. Then close shutter until flame no longer floats, and lock in place. A yellow streaming flame indicates insufficient air. Correct this condition by increasing air shutter opening.

5. Turn all main burner control valves fully clockwise to turn the main burners off.

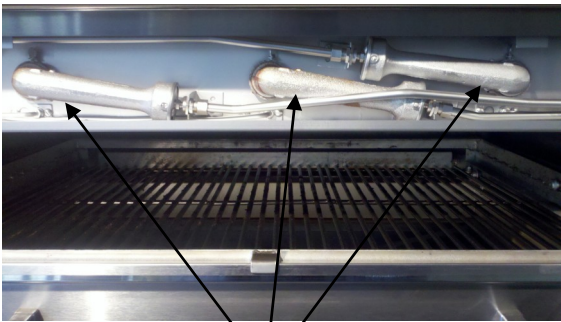

Main Burner Venturi w/ air mixer  
(Figure 10)

4. After all main burners are properly adjusted, reinstall the manifold cover.

# OPERATION

This appliance has been classified as commercial cooking equipment and must be operated by qualified and/or professional operating personnel.

## **WARNING**

**THE BROILER AND ITS PARTS ARE HOT. USE CARE WHEN OPERATING. CLEANING OR SERVICING THE UNIT.**

## **CAUTION**

**DO NOT OBSTRUCT THE FLOW OF COMBUSTION AND VENTILATION AIR TO THE BROILER. KEEP APPLIANCE AREA FREE AND CLEAR OF COMBUSTIBLES.**

### OPERATING CONTROLS

## **WARNING**

**IN THE EVENT A GAS ODOR IS DETECTED, SHUT DOWN UNITS MAIN GAS SHUTOFF VALVE AND CONTACT THE LOCAL GAS COMPANY OR GAS SUPPLIER FOR SERVICE.**

The following controls are used for operation of the broiler, Figure 11.

#### **Burner Control**

Used to turn the gas on or off. One control for each burner.

#### **Grid Height**

The grid is set to the desired cooking height by depressing the ball and adjusting the lever up or down.

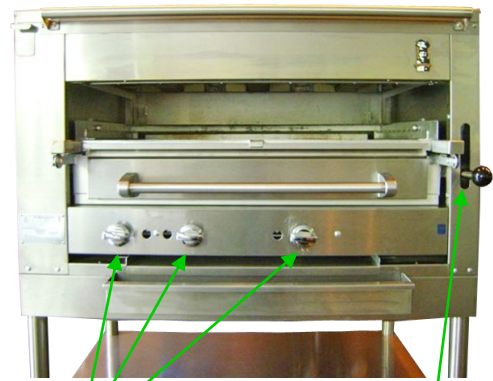

Burner Valve Knobs

Grid Height Control

Operating Controls  
(Figure 11)

### **Gas Control**

#### LIGHTING/RELIGHTING PILOT

1. Turn burner valve handle to off position and wait five (5) minutes.
2. Apply lighted match to pilot burner and/or check that pilot is burning.
3. Rotate burner valve handle counterclockwise to the full on position. Burner will ignite automatically.

## **IMPORTANT**

**DO NOT THROTTLE THE BURNER DOWN. BURNER MUST OPERATE FULLY OPEN AT ALL TIMES FOR PEAK PERFORMANCE**

4. If pilot becomes extinguished, turn main burner valve to the off position (fully clockwise) and wait five (5) minutes before relighting.

#### SHUTDOWN

1. Standby: To turn off, rotate main burner valve handle clockwise.

# OPERATION

2. Complete: Turn all gas main burner valves to off position and turn shutoff valve to broiler to the off position.



## ***IMPORTANT***

***NEVER THROTTLE THE BURNER DOWN.  
OPERATE BURNER IN FULL ON POSITION.***

### **Grid Height Adjustment**

Depress black ball and move lever up or down to desired cooking height. Figure 11.

# MAINTENANCE

## GENERAL CLEANING



### WARNING

**THE BROILER AND ITS PARTS ARE HOT. USE CARE WHEN OPERATING, CLEANING OR SERVICING THE UNIT.**

Lint and grease suspended in the air tend to collect in passages. Therefore, air openings, flue ways, and primary air openings, etc., should be periodically cleaned to prevent clogging. The entire broiler should be given a periodic general cleaning.

### Exterior

#### PAINTED SURFACE

Allow equipment to cool before cleaning exterior surfaces. Painted surfaces should be cleaned using a mild soap and warm water solution on a sponge or soft cloth.

Powder coated, copper, and other such painted or plated finishes are not covered under warranty. These finishes are subject to wear and may begin to discolor and/or chip within a short period of time. Caution should be taken when cleaning. Using a mild soap and water solution will help to maintain the look and finish.

#### STAINLESS STEEL SURFACES

Stainless steel is an alloy of iron which contains chromium. In the process of manufacturing stainless steel, chromium in the alloy is used to form the hard oxide coating on the surface. If this is taken off through corrosion or wear, it will rust like regular steel.

To remove dirt, grease or product residue from stainless steel, use water and a mild detergent if needed, applied with a sponge or lint-free cloth. Dry thoroughly with a lint-free cloth.

To remove grease and food splatter, or

condensed vapors that have baked on the equipment, you can use a (non-abrasive) commercial cream cleanser or baking soda and water, applied with a damp lint-free cloth or sponge. Rub cleanser as gently as possible (with grain) in the direction of the polished lines. **Do not rub in a circular motion**, it will damage the finish. Rinse surface after cleaning with a damp lint-free cloth and clean water. Dry thoroughly with a clean lint-free cloth. Drying thoroughly will prevent water spots which are harmful to the finish.



### CAUTION

**NEVER USE ABRASIVES, POWDERS, HARSH LIQUIDS, CAUSTICS, OR DYES AS THEY MAY LEAVE A FILM OR RESIDUE THAT WILL CLOG THE PORES OF THE SPECIAL COATING.**

### Precautions

- Strong bleaches tend to corrode many materials and should not come in contact with stainless steel sinks or utensils longer than 30 minutes. When these chemicals are used, the stainless should be rinsed thoroughly.
- Tincture of iodine or iron should not remain in contact with stainless surfaces. These solutions which cause stainless to discolor, should be rinsed off immediately after contact.

Some foods, such as mustard, mayonnaise, lemon juice, vinegar, salt or dressings containing these, will attack and corrode stainless. You should never store them in stainless containers.

- Ordinary steel wool pads should not be used to clean stainless; particles may lodge in the surface and rust. Allowing the steel wool pad to rest on a stainless surface may cause a rusty appearance. For difficult cleaning jobs such as removing

# MAINTENANCE

burned-on foods, nylon “sponges” or pads are recommended. When cleaning a highly polished, mirror finish, a nylon pad should be used to avoid scratching the finish.

- Gritty, hard abrasives will mar a stainless finish and are not recommended.
- Sharp knives or choppers usually have hard carbon steel edges and will leave their mark on stainless surfaces.

With only a little care, your stainless steel equipment and utensils will remain clean and bright for years to come. Stainless is hard, rust-resisting metal that adds beauty and luster to countless commercial products.

## Helpful Hints

- To remove streaks, rub stainless steel surface with olive oil.
- To clean and polish, simply moisten a lint-free cloth with undiluted white or cider vinegar and wipe clean. Vinegar can also be used to remove heat stains.
- Oil from fingerprints can etch or tarnish stainless steel, especially mirror-polished finishes. Wherever stainless steel is visible, use a glass cleaner to remove fingerprints at the end of the day, before the finish is permanently damaged.

## Daily

Remove grid racks, drip deflector (below grid rack), drip tray, and grease container. Thoroughly wash with mild detergent or soap. Excessive grease buildup may be removed by using a mildly abrasive cleanser.

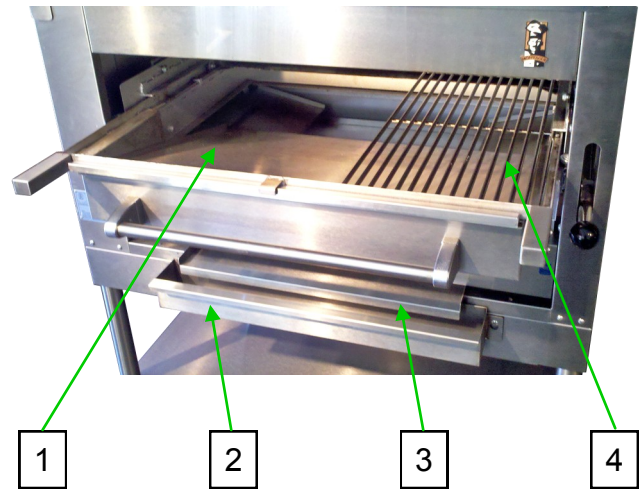

1	Drip Deflector
2	Grease Container
3	Drip Tray
4	Grid Rack

Items to Be Cleaned Daily  
(Figure 12)

## Griddle/Plancha

### SEASONING

Seasoning refers to the process of oil or lard being baked into the metal to create a non-stick surface for cooking on a new or recently cleaned griddle. If a griddle has been seasoned and food begins to stick, you should re-season your griddle.

To season follow these steps

1. Apply a coat of food grade oil and turn griddle on to a low setting (around 200 degrees F) for about 45 min to 1 hour.
2. Raise the temperature of the griddle (around 300 to 350 degrees F.) and apply additional layers until surface is slick and oil no longer seeps into griddle.

# MAINTENANCE

3. Repeat this process until griddle forms a non-stick surface. Once griddle reaches temperature turn griddle off and let cool.
4. Wipe off excess oil with lint-free cotton cloth.

## CLEANING

- After each use, scrape griddle clean with a griddle scraper when cooked food is removed to keep surface free of encrusted material and also prevent flavor transfer.
- After each day, while griddle is warm, clean surface with a griddle stone using a back and forth motion. For stainless steel, rub in the direction of the grain to not damage the surface. Clean grease trough thoroughly and empty grease container.
- Weekly, Allow griddle to cool completely and clean plate with a foodservice grade degreaser. Re-season griddle as needed, or apply a coating of cooking oil to prevent rust.
- A mixture of lemon juice and carbonated (soda) water can also be used while the griddle is warm. After applying mixture, rub griddle stone back and forth to clean surface. Dry thoroughly and re-season if needed, or apply a coating of cooking oil to prevent rust.

# MAINTENANCE

<b>Product Maintenance Schedule</b>												
Components	Jan	Feb	Mar	Apr	May	June	July	Aug	Sept	Oct	Nov	Dec
Pilots	1,2			1,2			1,2			1,2		
Burner						1,2						1,2
Regulator						1,2						1,2
Grease Container*	2	2	2	2	2	2	2	2	2	2	2	2
T-Couple (CE)	1,4			1,4			1,4			1,4		
Injectors	1,2			1,2			1,2			1,2		
Gaskets	1,4			1,4			1,4			1,4		
Bearings	1,5			1,5			1,5			1,5		
Valve (CE)	1,5			1,5			1,5			1,5		
Grid Iron*	2	2	2	2	2	2	2	2	2	2	2	2
Top Plate*	2	2	2	2	2	2	2	2	2	2	2	2
Air Mixer	1,2			1,2			1,2			1,2		
Interior	2			2			2			2		
Gear Mechanics	1,5			1,5			1,5			1,5		
Ceramics	1,2,4			1,2,4			1,2,4			1,2,4		
Drip Tray*	2	2	2	2	2	2	2	2	2	2	2	2

(1) Inspect      (2) Clean      (3) Adjust      (4) Replace (If needed)      (5) Lubricate

\*NOTE: Lack of maintenance may result in pre-mature failure of components.

\*NOTE: Parts marked with \* should be cleaned daily.

\*NOTE: Maintenance schedule may vary due to the gas heating value per country.

# SERVICE

## PARTS REMOVAL & REPLACEMENT PROCEDURES

Perform the following procedures to remove and replace parts. To eliminate mistakes when ordering parts, always provide the following information:

- Model Number
- Serial Number

These numbers are located on the nameplate.

### CAUTION

**TURN OFF THE BROILER GAS VALVE AND ALLOW BROILER TO COOL BEFORE REMOVING ANY COMPONENTS**

### Cover & Panels

### CAUTION

**TURN OFF THE GAS SUPPLY AT THE MANUAL SHUTOFF VALVE THAT IS NEXT TO THE BROILER BEFORE ATTEMPTING TO LOOSEN ANY GAS CONNECTIONS.**

### VENTURI COVER

Removal of the venture cover provides access to the air shutters, pilots, and main burner orifices.

1. Remove the two screws under the front edge of the venturi cover.
2. Lift the venturi cover from the broiler.

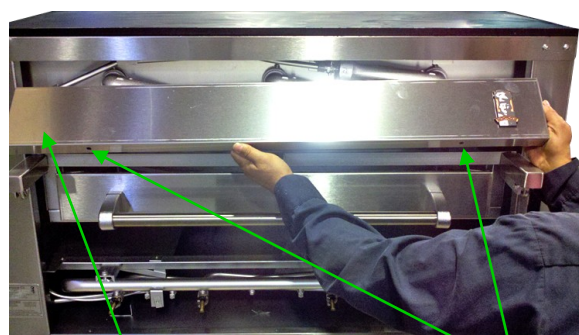

Venturi Cover

Screws

Venturi Cover  
(Figure 13)

### Control Panel Cover

Removal of the control panel cover provides access to the burner valves, pilot valves and carriage springs.

1. Turn the control valves to the full off position, then remove the control valve knobs.
2. Remove the two screws from the front of the control panel.

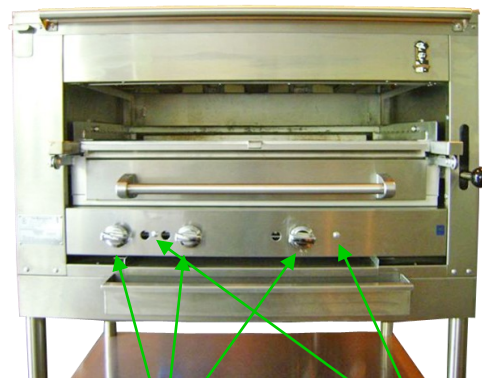

Burner Valve Knobs

Screws

Control Panel Cover  
(Figure 14)

# SERVICE

## Drip Deflector

The drip deflector is located below the grid frame and is angled toward the back of the broiler. Grease dripping onto the drip deflector runs off the back edge to the drip tray then flows forward into the horizontal grease container.

1. Pull the grid frame assembly forward to the stop.
2. Remove the grids from the frame assembly.
3. Lift the back edge of the drip deflector to disengage the drip deflector from the retaining latch.
4. Slide the drip deflector out at a downward angle.
5. When reinstalling the drip deflector, be sure to engage the front end under the retaining latch.

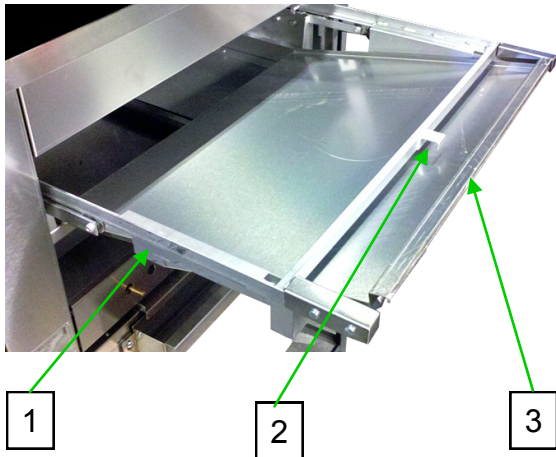

1	Grid Frame
2	Retaining Latch
3	Drip Deflector

Drip Deflector  
(Figure 15)

## Drip Tray and Horizontal Grease Container

The drip tray is located below the drip deflector. Grease dripping onto the drip deflector runs off the back edge to the drip tray then flows forward into the horizontal grease container.

1. Pull the drip tray straight out the front of the broiler.
2. Lift the horizontal grease container up and away from the broiler.

**NOTE:** When dumping the contents of the horizontal grease container, be sure to follow appropriate regulations for disposing of grease.

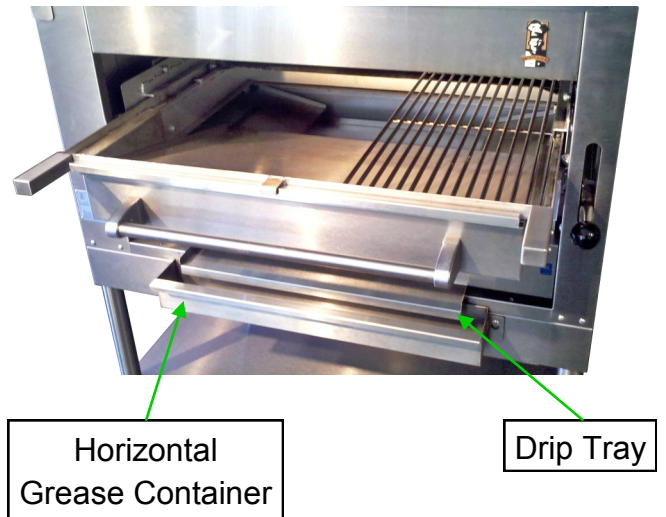

Drip Tray & Grease Container  
(Figure 16)

## Pilot

### ADJUSTMENT VALVE

The pilot adjustment valves are located on the manifold behind the control panel cover.



### CAUTION

**TURN OFF THE GAS SUPPLY AT THE MANUAL SHUTOFF VALVE THAT IS NEXT TO THE BROILER BEFORE ATTEMPTING TO LOOSEN ANY GAS CONNECTIONS.**

# SERVICE

1. Remove the control panel cover as described under **Covers and Panels** to access the pilot valve.
2. Disconnect the gas line from the back of the valve.
3. Unscrew the pilot valve from the manifold.
4. Install the new pilot valve with the adjustment screw facing the front of the broiler.

**NOTE:** Make sure that the pipe joint compound or pipe thread sealant that is being used is resistant to the corrosive actions of liquefied petroleum gases.

5. Connect the gas line to the back of the valve.
6. Turn the main gas shutoff valve to broiler to the “ON” position.



## WARNING

**ALL GAS JOINTS DISTURBED DURING SERVICING MUST BE CHECKED FOR LEAKS. CHECK WITH A SOAP AND WATER SOLUTION (BUBBLES). DO NOT USE AN OPEN FLAME.**

7. Light pilot and adjust pilot valve.
8. Reinstall control panel cover and control valve knobs.

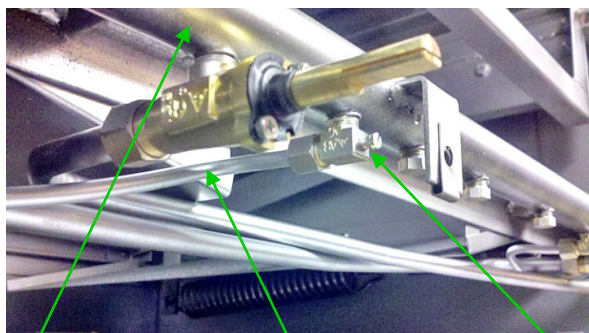

1

2

3

1	Manifold
2	Gas Line
3	Pilot Valve

Pilot Valve  
(Figure 17)

## PILOT ASSEMBLY AND ORIFICE

The pilot assembly is located adjacent to each burner. The connection for the pilot assembly is accessed by removing the venturi cover.

1. Remove the venturi cover as described in **Covers and Panels**.
2. Disconnect gas line from back of pilot assembly.
3. Unscrew the two screws securing the pilot assembly and pilot assembly bracket.

**NOTE:** Check condition of the pilot orifice and replace if damaged.

4. Install the new pilot assembly, orifice and pilot assembly bracket.
5. Connect the gas line to the back of the pilot assembly.

**NOTE:** Make sure that the pipe joint compound or pipe thread sealant that is being used is resistant to the corrosive actions of liquefied petroleum gases.

6. Turn the main gas shutoff valve to the broiler to the “ON” position.



## WARNING

**ALL GAS JOINTS DISTURBED DURING SERVICING MUST BE CHECKED FOR LEAKS. CHECK WITH A SOAP AND WATER SOLUTION (BUBBLES). DO NOT USE AN OPEN FLAME.**

# SERVICE

7. Light pilot and adjust pilot valve.
8. Reinstall venturi cover, heat shield, insulation and exterior top.

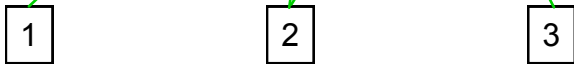
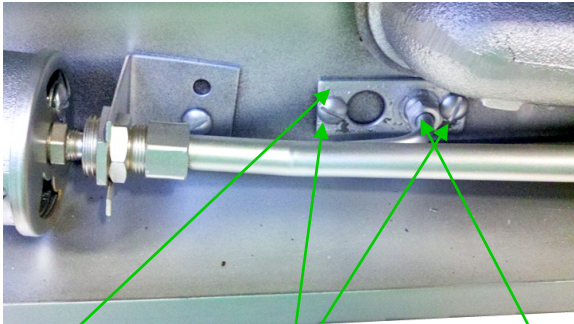

1	Pilot Bracket Assembly
2	Screws
3	Gas Line

Pilot Assembly Connection  
(Figure 18)

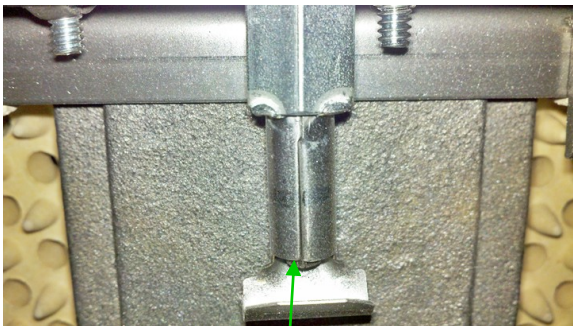

Pilot Assembly & Orifice

Pilot Assembly  
(Figure 19)

## Main Burners

The connection for the burners is accessed by removing the venturi cover. The burners are

accessed by removing the grids and carriage. The burner valves are accessed by removing the control panel cover.



### CAUTION

**TURN OFF THE GAS SUPPLY AT THE MAIN SHUTOFF VALVE THAT IS NEXT TO THE BROILER BEFORE ATTEMPTING TO LOOSEN ANY GAS CONNECTIONS.**

### BURNER ASSEMBLY, ORIFICE, AND VENTURI

1. Remove the venturi cover as described in Covers & Panels.
2. Remove the ceramic radiants from each side of the main burner to be replaced.
3. Loosen the set screw that attaches the main burner to the venturi assembly.
4. Slide the main burner out of the broiler.
5. If the venturi or orifice is to be replaced, disconnect the gas line to the venturi. Remove the gasket. Replace the gasket every time the venturi or burner is removed.
6. Loosen the lock nut so that the venturi can be removed from the orifice bracket.

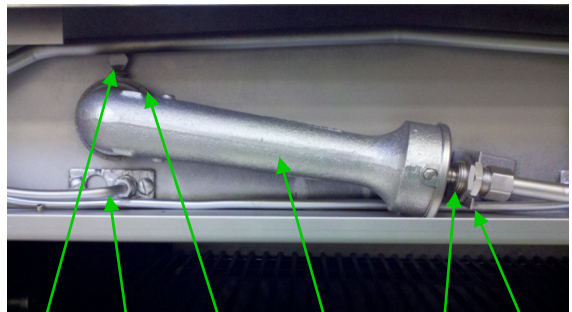

# SERVICE

1	Set Screw
2	Gas Input
3	Gasket
4	Venturi
5	Lock Nut
6	Bracket

Burner Pilot Assembly  
(Figure 20)

- Remove the orifice hex nut fitting from the venturi.
- Remove the orifice from the hex nut fitting.
- Reassemble by reversing procedure.



## WARNING

**ALL GAS JOINTS DISTURBED DURING SERVICING MUST BE CHECKED FOR LEAKS. CHECK WITH A SOAP AND WATER SOLUTION (BUBBLES). DO NOT USE AN OPEN FLAME.**

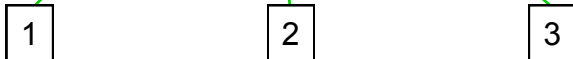
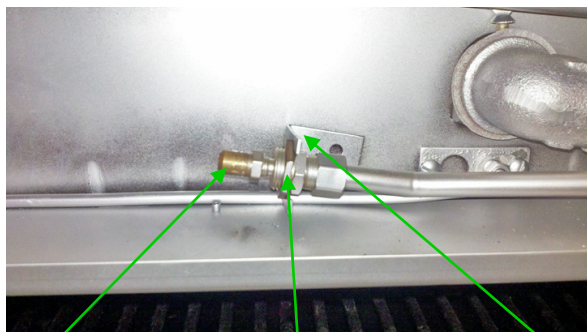

1	Orifice
2	Orifice Hex Fitting
3	Bracket

Orifice Assembly  
(Figure 21)

## BURNER VALVE

The burner valves are located on the manifold behind the control panel cover.



## CAUTION

**TURN OFF THE GAS SUPPLY AT THE MANUAL SHUTOFF VALVE THAT IS NEXT TO THE BROILER BEFORE ATTEMPTING TO LOOSEN ANY GAS CONNECTIONS.**

- Remove the control panel cover as described under Covers & Panels to access the burner valve.
- Disconnect the gas line from the back of the burner valve.
- Unscrew the burner valve from the manifold.
- Install the new burner valve.

**NOTE:** Make sure that the pipe joint compound or pipe thread sealant that is being used is resistant to the corrosive actions of liquefied petroleum gases.

- Connect the gas line to the back of the valve.
- Turn the main gas shutoff valve to the broiler to the "ON" position.



## WARNING

**ALL GAS JOINTS DISTURBED DURING SERVICING MUST BE CHECKED FOR LEAKS. CHECK WITH A SOAP AND WATER SOLUTION (BUBBLES). DO NOT USE AN OPEN FLAME.**

- Light pilot.
- Reinstall the control panel cover and control valve knobs.
- Turn burner valve full on and check that burner is properly lit.

# SERVICE

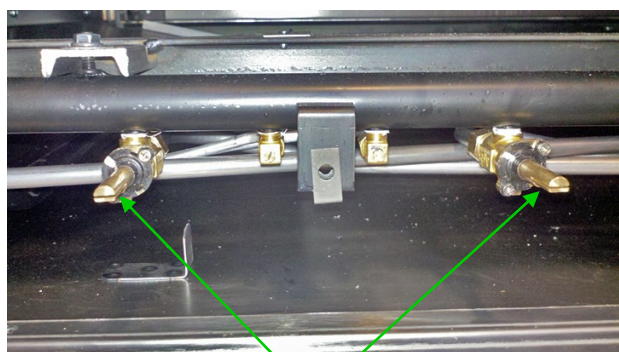

Burner Valves

Burner Valve  
(Figure 22)

## Carriage Position Handle

The carriage position handle consists of the parts shown in the following illustration and parts list.

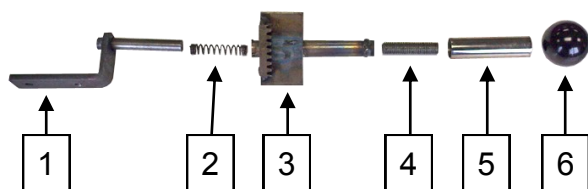

Item	Part #	Description
1	14442-8	Handle Bracket
2	32756-5	Compression Spring
3	03503-3	Gear & Tube Assembly
4	03506-8	Stud, Threaded
5	03504-1	Sleeve, Chrome
6	02033-8	Knob, Black Ball

Carriage Position Handle  
(Figure 11)

## Black Ball Knob

1. Remove the black ball knob by unscrewing it counterclockwise from the threaded stud.

2. Replace the black ball knob by screwing it clockwise onto the threaded stud.

## Chrome Sleeve

1. Turn off the burners.
2. Allow the broiler to cool to room temperature.
3. Remove the black ball knob by unscrewing it counterclockwise from the threaded stud.
4. Remove the sleeve from the tube/threaded stud assembly.
5. Replace the chrome sleeve by sliding the sleeve over the threaded stud.

## Threaded Stud

1. Turn off the burners.
2. Allow the broiler to cool to room temperature.
3. Remove the black ball knob by unscrewing it counterclockwise from the threaded stud.
4. Remove the chrome sleeve from the tube/threaded stud assembly.
5. Unscrew the threaded stud from the tube.
6. Reinstall the threaded stud by performing the above steps in reverse order. Screw the threaded stud about 1" into the threaded end of the tube.

## Gear and Tube Assembly

1. Turn off burners.
2. Allow the broiler to cool to room temperature.
3. Remove the black ball knob by unscrewing it counterclockwise from the threaded stud.

# SERVICE

4. Remove the chrome sleeve.
5. Remove 2 bolts and nuts from interior right side of carriage assy. Remove carriage release handle.
6. Slide the gear and tube assembly off the carriage release handle arm.
7. Replace the gear and tube assembly by performing the above steps in reverse order.

## Compression Spring

1. Turn off burners.
2. Allow the broiler to cool to room temperature.
3. Remove the black ball knob by unscrewing it counterclockwise from the threaded stud.
4. Remove the chrome sleeve.
5. Remove the threaded rod.
6. Remove the spring from the tube and gear assembly using needle nose pliers.
7. Replace the compression spring by performing the above steps in reverse order.

## Gear with Bracket

1. Turn off the burners.
2. Allow the broiler to cool to room temperature.
3. Raise grill to the top.
4. Remove all components of carriage position handle.
5. Remove the two screws and nuts that hold the gear with bracket to the right side panel.

6. Replace the gear with bracket by performing the above steps in reverse order.

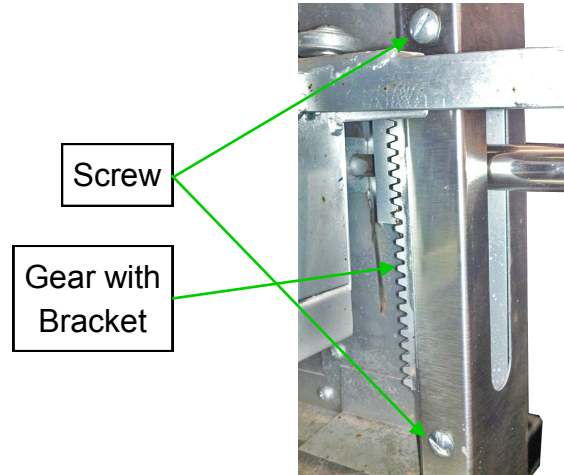

Gear with Bracket Assembly  
(Figure 23)

When service is needed, contact a local service company, dealer, or factory to perform mechanical maintenance and repairs. These instructions are intended for use by competent service personnel.



### CAUTION

**TURN OFF THE GAS SUPPLY AT THE MANUAL SHUTOFF VALVE THAT IS NEXT TO THE BROILER UNIT BEFORE ATTEMPTING TO LOOSEN ANY GAS CONNECTIONS.**

### GAS PRESSURE REGULATOR ADJUSTMENT PROCEDURE



### WARNING

**DO NOT ALLOW UNTRAINED PERSONNEL TO MAINTAIN OR SERVICE THE GAS PRESSURE REGULATOR.**

# SERVICE

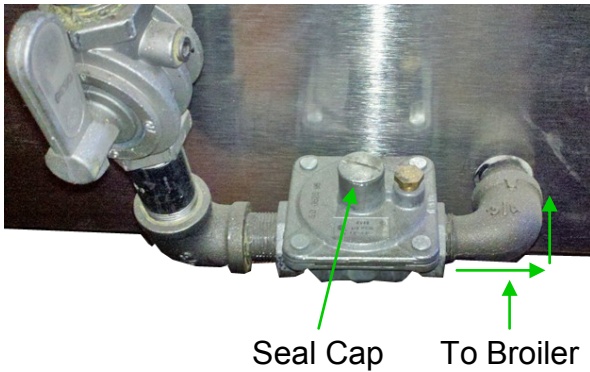

Gas Pressure Regulator  
(Figure 24)

1. Before adjusting the regulator, check incoming gas line pressure. Incoming pressure before the regulator should not exceed 1/2 psi.
2. If incoming pressure is not correct, have the gas source checked and adjusted as needed.
3. Make sure that the regulator is mounted in the horizontal position with the arrow pointing in the direction of the gas flow.
4. Connect a monometer to the pressure tap provided on the manifold between the regulator and the burner valves.
5. Check the manometer reading. The reading must be 6.0" W.C. for natural gas, or 10.0" W.C. for propane gas (dynamic).
6. If incoming line pressure is not correct, adjust the regulator. Remove seal cap on top of the regulator.
7. Insert a flat head screwdriver into the top hole of the regulator.
8. Turn the adjustment screw clockwise to increase the pressure, or counterclockwise to decrease the pressure.
9. While watching manometer, turn the adjustment screw to set proper manifold pressure.

## PILOT BURNER ADJUSTMENT PROCEDURE

1. Light the pilot burner as described in the Installation section on page 9.
2. If the pilot burner flame burns yellow, clean the pilot burner orifice and the pilot burner in order to ensure a steady blue flame. The orifice can be cleaned by washing it in a solvent such as trichloroethylene and/or blowing out with air.
3. If the pilot burner flame still burns yellow, replace the pilot burner orifice.
4. If the pilot flame does not extend 1/2" beyond the outer edges of the pilot shield, or if it extends more than 1/2" beyond the outer edges of the pilot shield, an adjustment is necessary.
5. Remove the control panel cover as described in Covers and Panels.
6. Turn the pilot adjustment valve screw until 1/2" flames are observed.

## CARRIAGE POSITION HANDLE ADJUSTMENT PROCEDURE

The carriage position handle can be placed in a number of vertical positions.

1. Grasp the black ball knob and press it in toward the front control panel.
2. Raise or lower the carriage assembly to the desired height.
3. Release pressure on the black ball knob to lock the carriage assembly at the desired height.

# SERVICE



Carriage Position Handle  
(Figure 25)

## Handle Tension Adjustment

If carriage is difficult to move or will not stay in place, the handle tension requires adjusting.

1. Remove black ball knob and chrome sleeve.
2. Turn threaded rod clockwise to increase tension; turn counter-clockwise to decrease tension.

## Carriage Tension Spring Adjustment Procedure

Carriage adjustments should be made with grid irons in place and allowance for product weight.

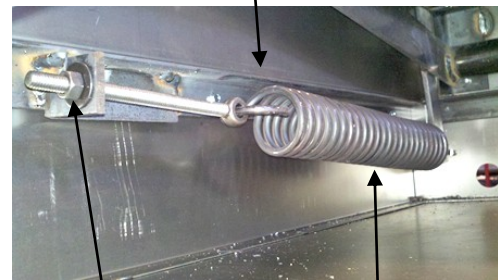

Adjustment  
Nut

Carriage  
Tension Spring

Carriage Tension Spring  
(Figure 26)

1. Remove Drip deflectors to locate the carriage tension spring adjustment nut. The adjustment nut is accessible from the front as follows:
  - Model #'s 36W36 and 43W36:** Through lower cabinet.
  - Model #'s 136W36 and V136W3:** Behind Valve Panel (Remove shields)
  - Model #'s C36, C45, 236W36 and 243W36:** Behind left and right front panels. (Remove drip shields)
2. Turn nut clockwise to increase tension or counterclockwise to decrease tension.
3. If one side of the grid is lower than the other side, turn the adjustment nut on the low side clockwise to level the grid.

# SERVICE

Symptom	Cause	Remedy
Pilot burner flames are burning yellow.	Gas too rich.	Perform the pilot burner adjustment procedure.
	Clogged pilot air passages.	Perform the pilot burner orifice removal and replacement procedure.
	Pilot not properly adjusted.	Perform the pilot adjustment valve adjustment procedure.
Pilot burner flames are less than or more than 1/2".	Pilot not properly adjusted.	Perform the pilot burner adjustment procedure.
	Clogged pilot burner.	Replace pilot burner.
One or more pilot burner flames cannot be adjusted.	Faulty pilot burner or orifice.	Perform the pilot burner removal and replacement procedure or orifice removal and replacement procedure as applicable.
	Faulty pilot valve.	Perform the pilot burner valve removal and replacement procedure.
Burner flames burning yellow.	Incorrect gas pressure or secondary air.	Check gas pressure. Adjust or clean air mixer.
One or more burner flames cannot be adjusted.	Dirty Venturi passage.	Perform the main burner orifice removal and replacement procedure.
	Incorrect gas pressure.	Check and adjust gas pressure.
	Ceramics cracked, broken or missing.	Replace damaged or missing ceramics. See Installation.
	Faulty burner valve.	Perform the main burner removal and replacement procedure.

# SERVICE

Symptom	Cause	Remedy
The heat of one or more burners is not uniform over the surface of the ceramic tiles.	Clogged burner ports.	Clean burner ports or perform the main burner removal and replacement procedure.
	Broken or missing ceramics.	Replace broken or missing ceramics.
	Dirty venturi passage.	Clean air mixer and venturi.
	Wrong gas pressure .	Check and adjust gas pressure.
Carriage assembly will not stay at a set height position.	Improper handle spring tension adjustment.	Perform the handle tension adjustment procedure.
	Worn or broken gear with bracket.	Perform the Gear with bracket removal and replacement procedure.
Carriage assembly moves up and down too easily or too hard.	Improper carriage spring tension adjustment.	Perform the carriage tension spring adjustment procedure.

# ORIFICE SIZE CHART - DRILL SIZE

**NOTE:** Orifice size may vary depending on country of destination and/or elevation.

<b>C36 &amp; C45</b>		
Nat. 6.0 W.C. (14.94 mbar)	Orifice #33	Part Number 6377-0
LP 10.0 W.C. (24.90 mbar)	Orifice #49	Part Number 2278-0
<b>136W36 Oven</b>		
Nat. 6.0 W.C. (14.94 mbar)	Orifice #37	Part Number 11700-5
LP 10.0 W.C. (24.90 mbar)	Orifice #49	Part Number 2278-0
<b>V136W36 Oven</b>		
Nat. 6.0 W.C. (14.94 mbar)	Orifice #36	Part Number 2361-2
LP 10.0 W.C. (24.90 mbar)	Orifice #47	Part Number 6151-4

# EXPLODED VIEW

C36 & C45

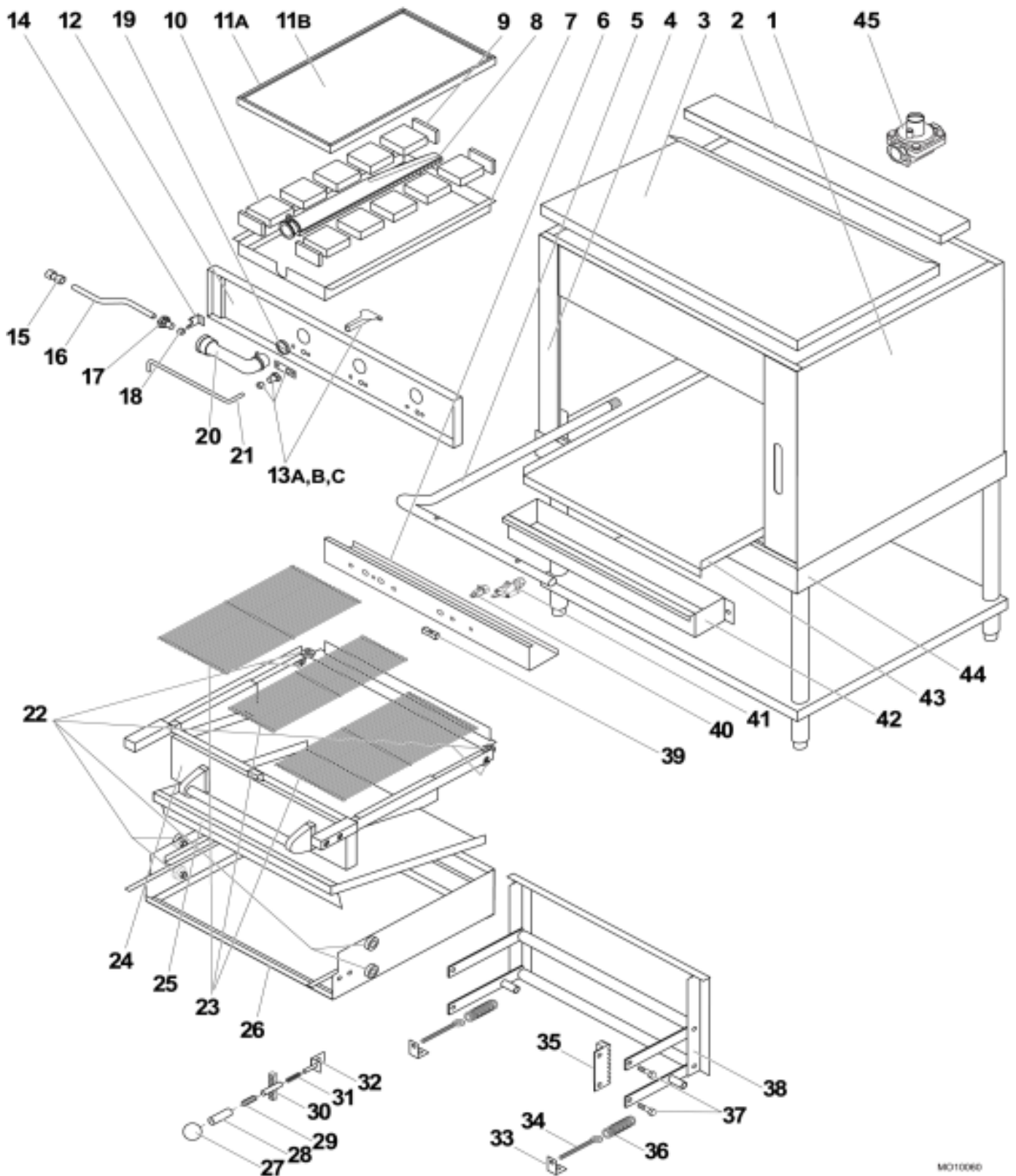

MO10060

# EXPLODED VIEW PARTS LIST

## C36 & 236W36

1	.....	12925-9	.....	Panel, Right Side	22	....	03396-0	.....	Bearing with Assembly
2A	....	25442-8	.....	Flue, Right Side	23A	..	01601-2	.....	Grid Iron, Left
2B	....	25440-1	.....	Flue, Left Side	23B	..	01600-4	.....	Grid Iron, Right
2C	....	12610-1	.....	Flue Deflector	23C	..	N/A	.....	Grid Iron, Center
3	.....	15355-9	.....	Exterior Top	24	....	38331-7	.....	Grid Frame Assembly
4	.....	12923-2	.....	Panel, Left Side	25	....	02549-1	.....	Drip Deflector
5	.....	01100-2	.....	Manifold	26	....	04655-8	.....	Carriage Assembly
6	.....	15367-2	.....	Valve Control Panel	27	....	02033-8	.....	Knob, Black Ball
7	.....	15211-0	.....	Frame, Burner Assembly	28	....	03504-1	.....	Handle, Sleeve
8	.....	03511-4	.....	Burner with Set Screw	29	....	03506-8	.....	Threaded Rod
9	.....	11614-9	.....	Insulator, Ceramic	30	....	03503-3	.....	Tube and Gear Assembly
10	....	11611-4	.....	Ceramic, Large	31	....	32756-5	.....	Spring, Handle
10A	..	28387-8	.....	Ceramic Kit (10 Ea. 11611-4) (4 Ea. 11614 ..... - 9)	32	....	14442-8	.....	Handle Assembly Bracket
11A	..	15352-4	.....	Heat Shield	33	....	15244-7	.....	Carriage Spring Mounting Bracket
11B	..	01430-3	.....	Insulation	34	....	01938-0	.....	Eye Bolt
12	....	15182-3	.....	Firebox Front Assembly	35	....	03507-6	.....	Gear, with Angle Bracket
13A	..	11769-2	.....	Pilot Burner Hex Compression Fitting	36	....	34258-0	.....	Carriage Spring
13B	..	02193-8	.....	Pilot Burner Orifice - Natural	37	....	28365-7	.....	Carriage Bolt
13C	..	02194-6	.....	Pilot Burner Orifice - Propane	38	....	13096-6	.....	Stabilizer Unit Assembly
14	....	03397-9	.....	Bracket, Orifice	39	....	02002-8	.....	Valve Handle with Set Screw
15	.....	01280-7	.....	Union, Tubing	40	....	01000-6	.....	Valve, Pilot
16	.....	01252-1	.....	Tubing, Steel	41	....	01007-3	.....	Valve, Burner
17	.....	06378-9	.....	Burner, Orifice Hex Compression Fitting	42A	..	06604-4	.....	Horizontal Grease Container - Painted
18A	..	04342-0	.....	Burner, Orifice - LP #49	42B	..	06603-6	.....	Horizontal Grease Container - Stainless ..... Steel
18B	..	17130-1	.....	Burner, Orifice - Nat #32	43	....	15246-3	.....	Drip Tray
19	.....	20923-6	.....	Gasket, Venturi	44	....	13064-8	.....	Stand, Modular - Painted
20	.....	15216-1	.....	Venturi, Air Mixer Assembly	45A	..	14605-6	.....	Gas Pressure Regulator - Natural
21	.....	01224-6	.....	Tubing, Aluminum	45B	..	01040-5	.....	Gas Pressure Regulator - Propane

## C45 & 243W36

1	.....	12925-9	.....	Panel, Right Side	22	....	03396-0	.....	Bearing with Assembly
2A	....	25442-8	.....	Flue, Right Side	23A	..	01601-2	.....	Grid Iron, Left
2B	....	25440-1	.....	Flue, Left Side	23B	..	01600-4	.....	Grid Iron, Right
2C	....	15391-5	.....	Flue Deflector	23C	..	01602-0	.....	Grid Iron, Center
3	.....	15385-0	.....	Exterior Top	24	....	38040-7	.....	Grid Frame Assembly
4	.....	12923-2	.....	Panel, Left Side	25	....	03548-3	.....	Drip Deflector
5	.....	01100-2	.....	Manifold	26	....	04657-4	.....	Carriage Assembly
6	.....	15392-3	.....	Valve Control Panel	27	....	02033-8	.....	Knob, Black Ball
7	.....	15211-0	.....	Frame, Burner Assembly	28	....	03504-1	.....	Handle, Sleeve
8	.....	03511-4	.....	Burner with Set Screw	29	....	03506-8	.....	Threaded Rod
9	.....	11614-9	.....	Insulator, Ceramic	30	....	03503-3	.....	Tube And Gear Assembly
10	....	11611-4	.....	Ceramic, Large	31	....	32756-5	.....	Spring, Handle
10A	..	28387-8	.....	Ceramic Kit (10 Ea. 11611-4) (4 Ea. 11614 ..... -9)	32	....	14442-8	.....	Handle Assembly Bracket
11A	..	15383-4	.....	Heat Shield	33	....	15244-7	.....	Carriage Spring Mounting Bracket
11B	..	01430-3	.....	Insulation	34	....	01938-0	.....	Eye Bolt
12	....	15295-1	.....	Firebox Front Assembly	35	....	03507-6	.....	Gear with Angle Bracket
13A	..	11769-2	.....	Pilot Burner Hex Compression Fitting	36	....	02034-6	.....	Carriage Spring
13B	..	02193-8	.....	Pilot Burner Orifice - Natural	37	....	28365-7	.....	Carriage Bolt
13C	..	02194-6	.....	Pilot Burner Orifice - Propane	38	....	13101-6	.....	Stabilizer Unit Assembly
14	....	03397-9	.....	Bracket, Orifice	39	....	02002-8	.....	Valve Handle with Set Screw
15	.....	01280-7	.....	Union, Tubing	40	....	01000-6	.....	Valve, Pilot
16	.....	01252-1	.....	Tubing, Steel	41	....	01007-3	.....	Valve, Burner
17	.....	06378-9	.....	Burner, Orifice Hex Compression Fitting	42A	..	06604-4	.....	Horizontal Grease Container - Painted
18A	..	04342-0	.....	Burner, Orifice - LP #49	42B	..	06603-6	.....	Horizontal Grease Container - Stainless ..... Steel
18B	..	17130-1	.....	Burner, Orifice - Nat #32	43	....	15366-4	.....	Drip Tray
19	.....	20923-6	.....	Gasket, Venturi	44	....	13056-6	.....	Stand, Modular - Painted
20	.....	15216-1	.....	Venturi, Air Mixer Assembly	45A	..	14605-6	.....	Gas Pressure Regulator - Natural
21	.....	01224-6	.....	Tubing, Aluminum	45B	..	01040-5	.....	Gas Pressure Regulator - Propane

# EXPLODED VIEW

36W36 & 43W36

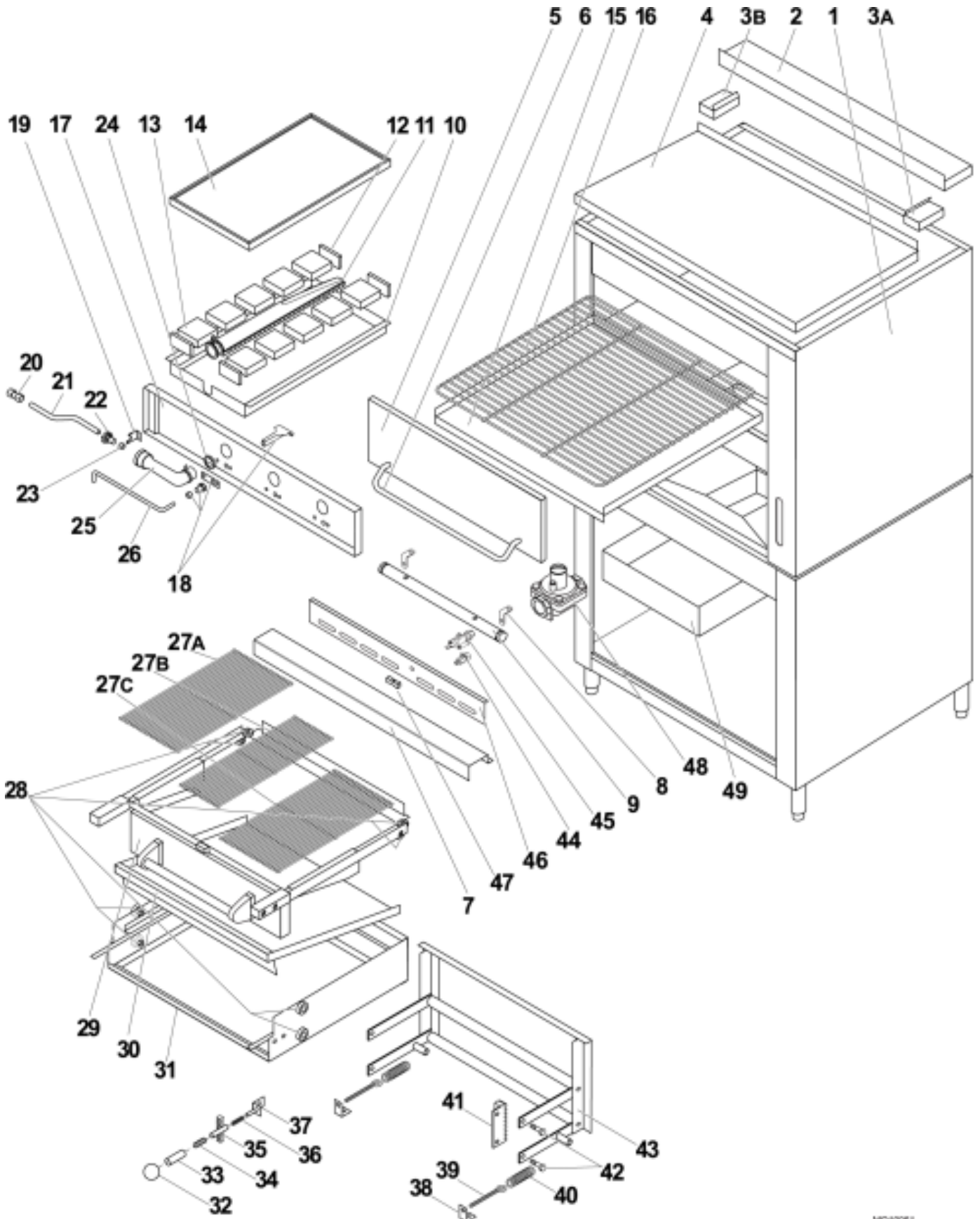

MD10261



## WARNING

**If not installed, operated and maintained in accordance with the manufacturer's instructions, this product could expose you to substances in fuel or in fuel combustion which can cause death or serious illness and which are known to the State of California to cause cancer, birth defects or other reproductive harm.**

The State of California enacted the California Safe Drinking Water and Toxic Enforcement Act of 1986, (Prop. 65), which "prohibits any person in the course of doing business from knowingly and intentionally exposing any individual to a chemical known to the State of California to cause cancer or reproductive toxicity without first giving clear and reasonable warning to such individuals." The Governor's Scientific Advisory Panel added carbon monoxide to the list of hazardous chemicals known to cause reproductive harm.

In order to establish full compliance with Proposition 65, we attached a yellow warning label to each gas fired unit manufactured by the Montague Company.

Carbon monoxide would not be present in concentrations that would pose a "significant risk" to the consumer when the equipment is installed, operated and maintained as follows:

1. Installed in accordance with all local codes, or in the absence of local codes, with the current National Fuel Gas Code Z223.1.
2. Installed under a properly designed and operating exhaust hood.
3. Connected to the type of gas for which the unit is equipped.
4. Proper appliance pressure regulator installed on the gas supply line and adjusted for the manifold pressure marked on the rating plate.
5. Adequate air supply to the unit.
6. The equipment is operated in the manner intended using the proper utensil for that type of appliance.
7. Keep the equipment clean and have it checked periodically.
8. Burner air adjustments, mechanical maintenance and repairs should be performed by qualified service personnel.

If the equipment is not installed, operated and maintained in accordance with the above, concentrations of carbon monoxide in excess of the established limits could present in the kitchen environment.

ALL PERSONNEL IN THE WORKPLACE WHO MAY BE SUBJECT TO ANY EXPOSURE OF CARBON MONOXIDE MUST BE WARNED OF SUCH POSSIBLE EXPOSURE. THIS WARNING SHOULD BE CONVEYED IN A MANNER SO THAT IT IS CLEARLY UNDERSTOOD BY THE EMPLOYEE, AND THE EMPLOYEE SHOULD BE ASKED IF IN FACT HE OR SHE UNDERSTANDS THE CORRECT METHOD OF OPERATION OF THE EQUIPMENT AND THAT A RISK OF EXPOSURE EXISTS IF THE EQUIPMENT IS OPERATED IMPROPERLY.



**The MONTAGUE COMPANY**

1830 Stearman Avenue, P.O. Box 4954 Hayward, CA 94540-4954

# IMPORTANT

When ordering parts, to eliminate mistakes and facilitate deliver, always give the following information:

Serial No. \_\_\_\_\_

Model No. \_\_\_\_\_

Change No. \_\_\_\_\_

## Name and Number of Part

<b>Model No.</b>	<b>Change No.</b>	<b>Serial No.</b>	
------------------	-------------------	-------------------	--

**The Montague Company**  
1830 Stearman Avenue  
P.O. Box 4954  
Hayward, CA 94540-4954

P/N: 40583-3 RD 4/13