



LEGEND™ Heavy-Duty 36" (914mm) Gas Range

Item No. _____

Project _____

Quantity _____

(-559S) Top Series



Model 136-559S

SHORT/BID SPECIFICATION

Range shall be a Montague **Legend** Model [Specify one]:

- 136-559S**, with front-vented 40,000 BTU/hr conventional oven with counterweighted door, porcelainized steel interior, three-position rack guides and one wire pan rack standard
- V136-559S**, with indirect-fired 45,000 BTU/hr convection oven with counterweighted door, porcelainized steel interior, five-position rack guides and three wire pan racks standard
- 36-559S**, with open front cabinet base with two shelves;
- M36-559S**, with 28" (711mm) high modular stand with stainless steel tubular legs;

...a 36" (914mm) wide heavy-duty gas-fired unit with three front heavy-duty cast iron, precision-ground open top grates, over 30,000 BTU/hr lift off star burners and (three) rear step-up 15,000 BTU/hr solid cast iron hot tops, with individual burner controls and automatic standing pilots; with stainless steel front and exterior bottom, black painted sides and back 4" (102mm) high flue riser and 3" (76mm) deep front rail standard; plus all the features listed and options/accessories checked:

RANGE TOP FEATURES:

Three 12" wide x 15-1/2" deep (305 x 354mm) combination open/hot burner tops in front, with:

- Heavily ribbed cast iron, surface-ground top grates
- Large diameter 30,000 BTU/hr lift off star burners with raised ports in front
- Solid hot top in back with 15,000 BTU/hr burner
- Automatic, standing pilots
- Drip pan positioned under open burners

MODEL GUIDE		
✓ Model No.	Base Style/Type	-559S Range Top
136-559S	With Standard Oven	
V136-559S	With Convection Oven	
36-559S	With Cabinet Base	
M36-559S	With Modular Stand	

STANDARD (136-559S MODEL) OVEN FEATURES:

- 26" wide x 28" deep x 15" high (660 x 711 x 381mm) cooking compartment
- Accepts 18" x 26" (457 x 660mm) pans sideways or lengthwise
- Front-venting oven design for more even cooking
- Heavy-duty counterweighted oven door — no springs
- Three-position adjustable nickel-plated rack supports, with one rack standard
- Interior panels and door porcelain lined for long life & easy cleaning
- Low-to-500°F (260°C) thermostat mounted in insulated cool zone
- 40,000 BTU/hr cast iron burner with automatic ignition safety pilot

CONVECTION (V136-559S MODEL) OVEN FEATURES:

- 26" wide x 22-1/4" deep x 15" high (660 x 565 x 381mm) cooking compartment
- Muffled, indirect-fired design with blower, for fast, even cooking
- Heavy-duty counterweighted oven door — no springs
- Five-position adjustable nickel-plated rack supports, with three racks standard
- Interior panels and door porcelain lined for long life & easy cleaning
- Low-to-500°F (260°C) thermostat mounted in insulated cool zone
- 45,000 BTU/hr cast iron burner with automatic ignition safety pilot
- 6' (1829mm) cord with 3-prong plug (grounding NEMA 5-15P)

STANDARD CONSTRUCTION FEATURES:

- Satin finish stainless steel front and exterior bottom with 3" (76mm) deep front rail
- Other surfaces painted black with electrolytic zinc undercoating
- Stainless steel 8" (204mm) rear flue riser standard
- 6" (152mm) adjustable stainless steel legs standard (Except M36-559S Model)
- 28" (711mm) stainless steel tubular legs standard with M36-559 Model
- Cabinet base with sides, back panel and two shelves on 36-559S Model
- 1-1/4" NPT front gas manifold with 1/2 union on each end

AGENCY APPROVALS:

- NSF Listed
- ETL Design Certified to ANSI Z83.11 • CSA 1.8
- CE Approved • EN 203-1



HDS-17 [Rev. 1/12]

Item No. _____

Project _____

Quantity _____

LEGEND™ Heavy-Duty 36" (914mm) Gas Range

(-559S) Top Series

Dimensions in brackets are millimeters

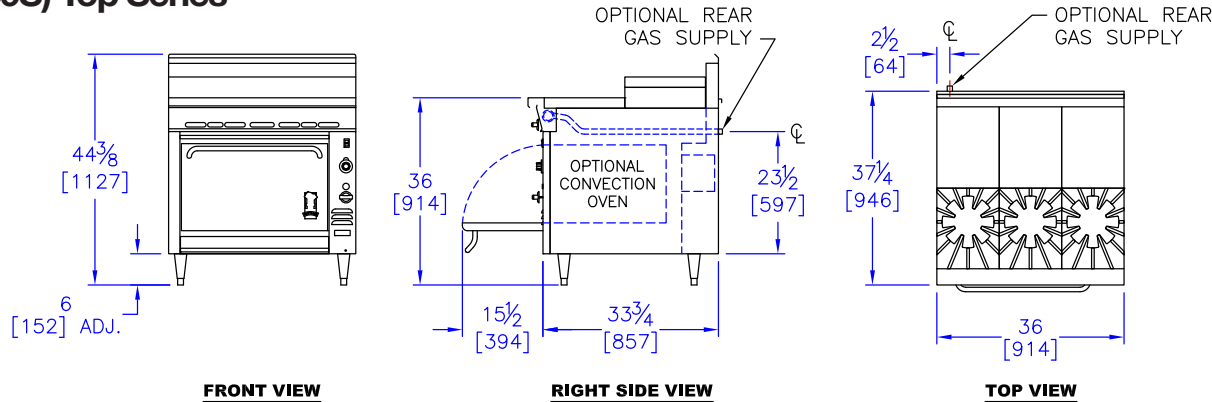

OPTIONS GUIDE:

Open Burners Top Section:

- 42" (1067mm) range depth [Add Suffix: -40]
- 304 stainless steel burner box assembly

Back Panels/Shelves:

- 18" (457mm) high back
- Single high shelf
- Double high shelf
- 6" (152mm) wide stainless steel plate shelf
- 8" (203mm) wide stainless steel plate shelf

Oven:

- Cast iron oven bottom
- Extra oven racks: ____ea.
- 650°F (343°C) finishing oven with cast iron oven bottom-*includes cast iron oven bottom option* [see Heavy Duty option page HDS-46]

Manifolds: [Left rear with pressure regulator]:

- 1" NPT up to 400,000 BTU/hr
- Manifold Cap: left side right side
- Stainless Manifold Cover: left side right side

Electrical (V136):

- 120 V, 1-phase, 60 Hz, 3.4 A (standard, with 6' (1.8m) NEMA 5-15P power cord)
- 208-240 V, 1-phase, 60 Hz, 1.7 A

Controls: [see Heavy Duty option page HDS-46]

- Electronic rangetop pilot ignition; electronic oven control (V136 & 136 ovens only)
- Flame failure rangetop safety valves
- Electronic rangetop pilot ignition & flame failure rangetop safety valves; electronic oven control (V136 & 136 ovens only)

Special Finish: [Consult Factory]

Finish:

- Stainless steel left side panel
- Stainless steel right side panel
- Stainless steel back panel
- Stainless steel shelves and sides [36-559S Cabinet Model]

General:

- Casters – set of four 5" (127mm) casters
- Flanged feet with holes

Flex Connector Kit [1"]NPT:

- 3' (914mm) 4' (1219mm)

Security Options/Prison Package

[Consult Factory]

International Approvals:

- CE - Conformance Européenne - EN203-1
Includes flame failure valve option
- Canadian Approval

INSTALLATION REQUIREMENTS & SHIPPING INFORMATION

- Ovens & ranges must be installed in accordance with local codes or in their absence with the National Fuel Gas Code: ANSI Z223.1; Natural Fuel Gas Code: CAN/CGA-B149.1 or Propane Installation Code: CAN/CGA-B149.2, as applicable. Compliance with codes is the responsibility of the Owner and Installer.
- An adequate ventilation system is required. Refer to National Fire Protection Association Standard No. 96, "Vapor Removal from Cooking Equipment."
- This appliance is intended for commercial use by professionally trained personnel. NOT intended for Residential Use.
- Specify installation elevation: _____ if above 2,000 ft (610m).
- GAS INLET SIZE (All Models): 1-1/4 (32mm) front manifold with 1/2 union on each end provided for battery connection. A properly sized gas pressure regulator must be furnished by the Installer.
- The incoming gas line pressure into the regulator should be 8"-14" w.c. for natural gas, and 12"-14" w.c. for propane gas.

Minimum Clearances	Combustible Construction	Noncombustible Construction
From Back Wall*	2" (51mm)	0"
Left & Right Side**	15" (152mm)	0"
With 6" (152mm) legs	Suitable for installation on combustible floors	
*V136 Models require 2" (51mm) for motor clearance at rear		

Specify Type of Gas:		<input type="checkbox"/> Natural	<input type="checkbox"/> Propane	Electrical	Shipping Weight	Shipping Class	Cube (Crated) ft ³ /m ³
Gas Delivery Pressure:		6.0" WC	10.0" WC	120V			
Models:	Burners	BTU/hr* (kW)	BTU/hr* (kW)	Amperage			
136-559S	7	175,000 (51.3)	175,000 (51.3)	---	580 lbs (263 kg)	85	32/.9
V136-559S	7	180,000 (52.8)	180,000 (52.8)	3.4	600 lbs (272 kg)	85	32/.9
36-559S	6	135,000 (39.6)	135,000 (39.6)	---	405 lbs (184 kg)	85	27/.75
M36-559S	6	135,000 (39.6)	135,000 (39.6)	---	342 lbs (155 kg)	85	18/.5

Entry Clearance: 30" (762mm) uncrated, with legs removed [All Models]

Due to continuous product improvements, specifications are subject to change without notice.



THE MONTAGUE COMPANY
 1830 Stearman Avenue, Hayward, CA 94545
 800 345-1830 • Fax: 510 785-3342
 www.montaguecompany.com



HDS-17 [Rev. 1/12]