

# MONTAGUE LEGEND

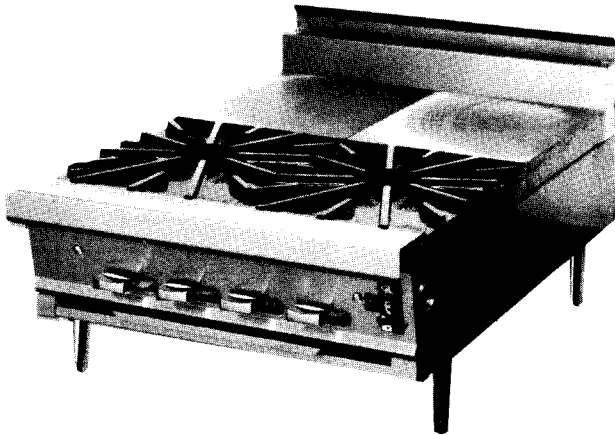

## Gas Heavy Duty Counter Ranges and Add-A-Units — Hot Tops



**C24-559 —**  
Two 12" Open / Hot Tops  
Shown with standard 4" S/S legs.

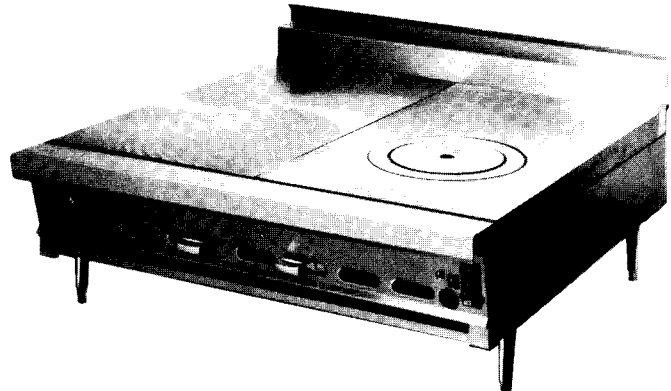

**C36-15 — One 18" Solid / One 18" Ring and Cover Hot Top(s)**  
Shown with standard 4" S/S legs.

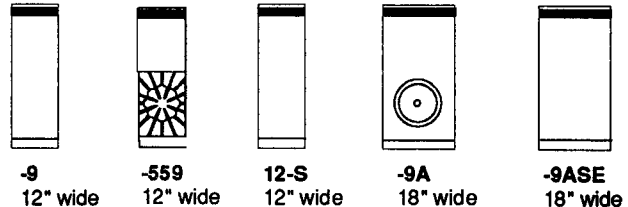

### GENERAL

12" and 18" wide Hot Tops have a machined cast iron surface with heat conduction studs on the bottom for more efficient heat transfer. Designed for installation on a *counter* or a *refrigerated base*. Various uses — from boiling water, to simmering, to cooking lower temperature foods such as cream-based soups, to keeping prepared food warm to sauteing with multiple pans. High volume cooking.

#### MODELS:

**C12-9, C24-9, C36-9 — Solid Front-Fired Hot Tops.**

12" wide x 31-1/8" deep. Each 12" Hot Top is front fired by one burner rated at 18,500 Btu/Hr.

OPTIONAL, (\*extra cost):

\***-9E, Even-Heat Hot Tops.** Each 12" top is heated by one burner rated at 20,000 Btu/Hr.

NOTE: When a 3/4" or 1" rear gas inlet is used, the Even-Heat burner(s) must be installed, (-3, -4 and -9 tops).

**-559, Combination Open Top / Hot Top** — (In-lieu-of 12" Hot Top.) Combination 20,000 Btu/Hr front open burner and 15,000 Btu/Hr rear burner under a solid Hot Top.

Located:  1, right  1, center  1, left

**C18-9A, C36-9A — French-type Hot Tops with Ring and Cover.** 18" wide x 31-1/8" deep, cast iron. Each 18" top is front fired by one Banjo burner rated at 35,000 Btu/Hr.

**C18-9ASE, C36-9ASE — Solid Even-Heat Hot Tops.** 18" wide x 31-1/8" deep, cast iron. Each 18" top is heated with two Even Heat burners rated at 20,000 Btu/Hr each.

**C12-S, C18-S, C24-S, C36-S — Work Tops.** Solid stainless steel, one piece sections replace range tops with a durable, easy to clean work surface:  12"  18"  24"  36"

### STANDARD FEATURES

- High temperature commercial type burner valves with constant burning pilots are used for automatic lighting.
- An insulated partition to confine heat to each individual top configuration is furnished.
- 4" flue riser.
- 4" S/S tapered legs.

### FINISH

#### EXTERIOR:

Standard — Satin finish stainless steel front, including 4" flue riser. Remaining exterior black. All painted surfaces have electrolytic zinc undercoating for corrosion protection and longer life.

OPTIONAL, (\*extra cost):

\*S/S left side  \*S/S right side  \*S/S back

### OPTIONS, (\*extra cost)

- \*18" HIGH BACK — S/S front.
- \*42" RANGE DEPTH — suffix **-40**. Add 6" to OA depth.
- \*LEFT OR RIGHT REAR MANIFOLD — with pressure regulator. (Specify left or right when ordering.)
  - \*3/4" NPT up to 165,000 Btu/Hr
  - \*3/4" NPT up to 320,000 Btu/Hr
  - \* 1" NPT up to 500,000 Btu/Hr
- CAP, MANIFOLD:  left side  right side (Must specify when ordering.)
- \*S/S COVER, MANIFOLD:  left side  right side
- \*PLATE SHELF — 6" wide, S/S.
- \*4" HIGH BASE — (no legs).  \*with 24" s/s legs. Prefix **M**.
- \*EQUIPMENT STANDS — Consult factory.
- \*UNITIZED CONSTRUCTION — Consult factory.
- \*SECURITY OPTIONS — i.e. prisons. Consult factory.



# MONTAGUE **LEGEND** Counter Ranges & Add-A-Units – Hot Tops

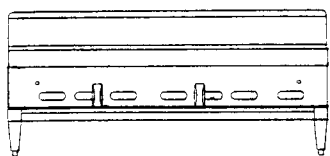

**C36-9 FRONT VIEW—**  
Shown with standard 4" legs.

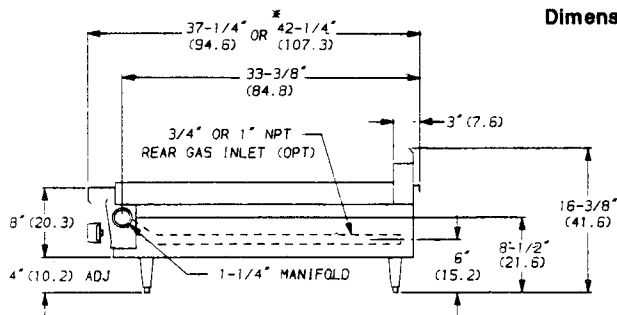

**SIDE VIEW—**  
Shown with standard 4" legs.  
Note dimensions for 42" depth.

Dimensions in parenthesis are centimeters.

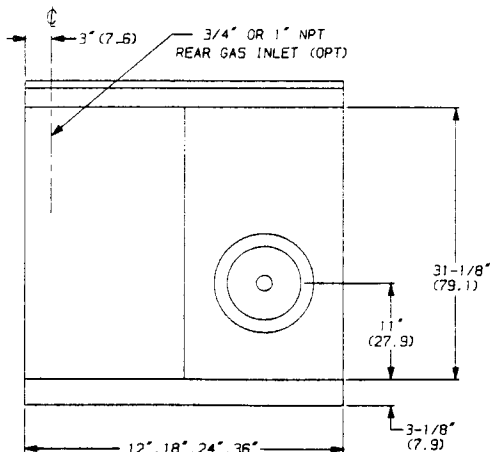

**C36-15 TOP VIEW —**  
Combination 18" Hot Top / 18" Hot Top  
with Ring and Cover shown . 36" wide.

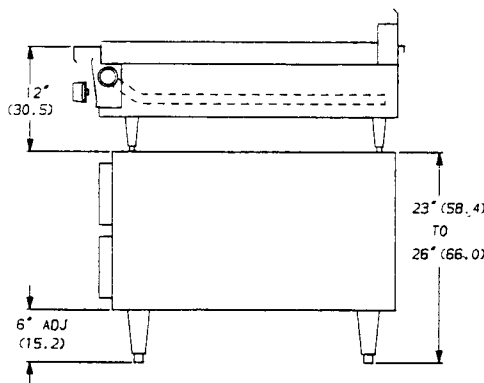

**SIDE VIEW—**  
Shown with standard 4" legs.  
Refrigerated base supplied by others.

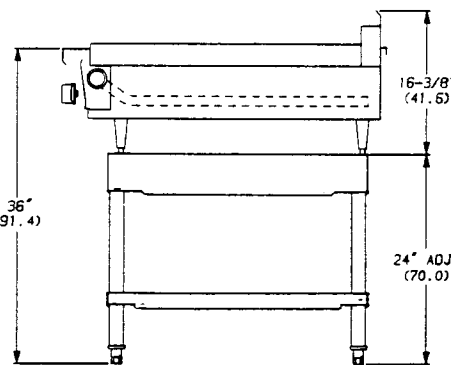

**SIDE VIEW—**  
Shown with standard 4" legs.  
Mounted on optional equipment stand.

## IMPORTANT

Gas ranges must be installed in accordance with local codes or, in the absence of local codes, with the National Fuel Gas Code ANSI Z223.1. Compliance with codes is the responsibility of the Owner and Installer.

*Adequate ventilation system required.* Refer to The National Fire Protection Association Standard No 96, "Vapor Removal from Cooking Equipment".

Minimum Clearances:	Combustible Construction	Noncombustible Construction
Back Wall:	2"	0"
Left & Right Side:	6"	0"

With or without 4" legs: Must be installed on noncombustible counters only.

**AGA Design Certified:** In accordance with ANSI Z83.11 Gas Foodservice Equipment — Ranges. Note: These appliances are intended for commercial use by professionally trained personnel. *NOT Intended For Household Use.*

*Montague's continuing commitment to quality / product improvement can cause specification and design changes without prior notice.*

TYPE OF GAS		Natural 4.0" WC	Propane 10" WC
Model	# burners	TOTAL BTU/HR	TOTAL BTU/HR
C12-9	1	18,500	18,500
C12-559	2	35,000	35,000
C12-9E	1	20,000	20,000
C18-9A	1	35,000	35,000
C18-9ASE	2	40,000	40,000
C24-9	2	37,000	37,000
C24-559	4	70,000	70,000
C24-9E	2	40,000	40,000
C36-9	3	55,500	55,500
C36-559	6	105,000	105,000
C36-9A	2	70,000	70,000
C36-9ASE	4	80,000	80,000

## GAS INLET SIZE (for all models):

1-1/4" front manifold with 1/2 union on each end provided for battery connection. Properly sized gas pressure regulator must be *Furnished By The Installer.*

Note: Specify type of gas  Natural  Propane  
Specify elevation if installing above 2000 feet.

SHIPPING WEIGHT, (Lbs.): Class 85

C12-9 ...134	C18-9ASE...192	C36-9 ...375
C12-9E ...134	C24-9 ...236	C36-559 ...325
C12-559...115	C24-9E ...236	C36-9A ...340
C18-9A ...220	C24-559 ...280	C36-9ASE...340

ENTRY CLEARANCE, (uncrated): All models ...12"

APPROX. CUBIC FT., (crated):

C12... 4      C18... 5      C24... 7      C36... 10

