

MONTAGUE LEGEND

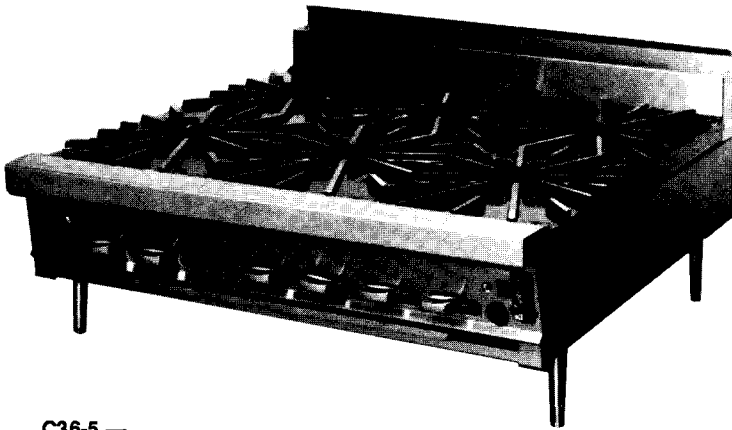

Gas Heavy Duty Counter Ranges and Add-A-Units — Open Tops



C36-5 —
Shown with standard 4" S/S legs.

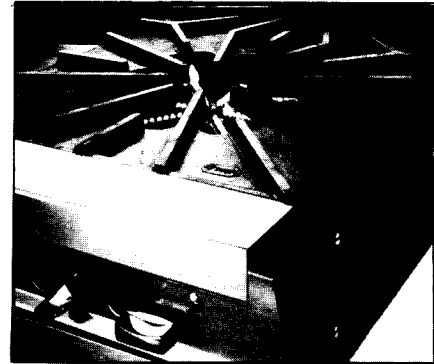

C18-5A



-5
12" wide



-559
12" wide

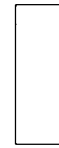

12-S
12" wide
Work Top



-5A
18" wide



**Optional
Ribbon
Grate**
12" wide

GENERAL

12" and 18" wide precision ground cast iron Open Tops provide smooth sliding of pots and pans without the fear of tipping. The heavily ribbed grates are acclaimed for their exceptional durability.

Recent tests at the Foodservice Technology Center, San Ramon, found this range easy to operate, clean and flexible enough to meet their preparation needs — from simmering to sauteing. Designed for installation on a *counter* or a *refrigerated base*.

MODELS:

C12-5, C24-5, C36-5 — One, two or three 12" wide x 31-1/8" deep Open Top sections are fired by two Star burners rated at 20,000 Btu/Hr each burner. 40,000 Btu/Hr total per section.

OPTIONS, *(extra cost):

-559 Combination Open Top / Hot Top — (In-lieu-of 12" Open Top). Combination 20,000 Btu/Hr front open burner and 15,000 Btu/Hr rear burner under a solid Hot Top.
Located: 1, right 1, center 1, left

***Ribbon Grate**, cast iron. (In-lieu-of 12" Open Top).
Note: Used for simmering in low heat applications. For use with 20,000 Btu/Hr burners.

Located: *1, right *1, center *1, left

***30,000 Btu/Hr Star open burner** for use with Natural gas:
Located: *front *back *front and back

C18-5A, C36-5A — One or two 18" wide x 31-1/8" deep heavily ribbed cast iron grates fired by two Star burners rated at 20,000 Btu/Hr each burner. 40,000 Btu/Hr total per 18" section. (Optional 30,000 Btu/Hr per burner is available. See above.)

C12-S, C18-S, C24-S, C36-S Work Tops. Solid stainless steel, one piece sections replace range tops with a durable, easy to clean work surface: * 12" * 18" *24" *36"

STANDARD FEATURES

- 12" to 36" wide x 36-5/8" deep x 12" high to top of range, (16" OA height including 4" flue riser.) 4" legs are standard.
- High temperature commercial type burner valves with constant burning pilots are used for automatic lighting.
- Each burner has raised ports to help prevent clogging from spillovers and for better combustion.
- Full width drip pan provided under all burners.

FINISH

EXTERIOR:

Standard — Satin finish stainless steel front, including 4" flue riser. Remaining exterior black. All painted surfaces have electrolytic zinc undercoating for corrosion protection and longer life.

OPTIONAL, *(extra cost):

*S/S left side *S/S right side *S/S back

OPTIONS, *(extra cost)

*18" HIGH BACK — S/S front.

*42" RANGE DEPTH — suffix **-40**. Add 6" to OA depth.

*BURNER BOX ASSEMBLY, S/S

*LEFT OR RIGHT REAR MANIFOLD —

with pressure regulator. (Specify left or right when ordering.)

*3/4" NPT up to 165,000 Btu/Hr

*3/4" NPT up to 320,000 Btu/Hr

* 1" NPT up to 500,000 Btu/Hr

CAP, MANIFOLD: left side right side

(Must specify when ordering.)

*S/S COVER, MANIFOLD: left side right side

*PLATE SHELF — 6" wide, S/S.

*4" HIGH BASE — (no legs). *with 24" s/s legs. Prefix **M**.

*EQUIPMENT STANDS — Consult factory.

*UNITIZED CONSTRUCTION — Consult factory.

*SECURITY OPTIONS — i.e. prisons. Consult factory.



MONTAGUE LEGEND

Counter Ranges & Add-A-Units—Open Tops

Dimensions in parentheses are centimeters.

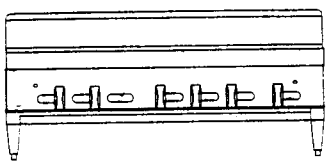

C36-5 FRONT VIEW—
Shown with standard 4" legs.

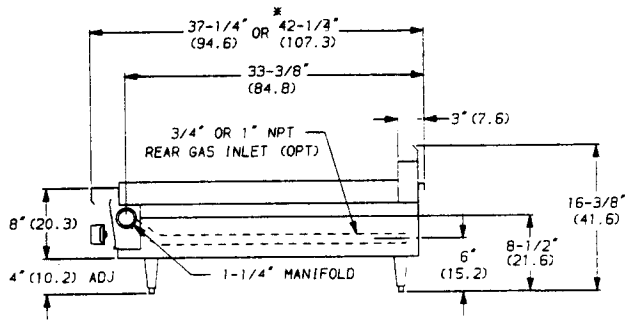

SIDE VIEW—
Shown with standard 4" legs.
Note dimensions for 42" depth.

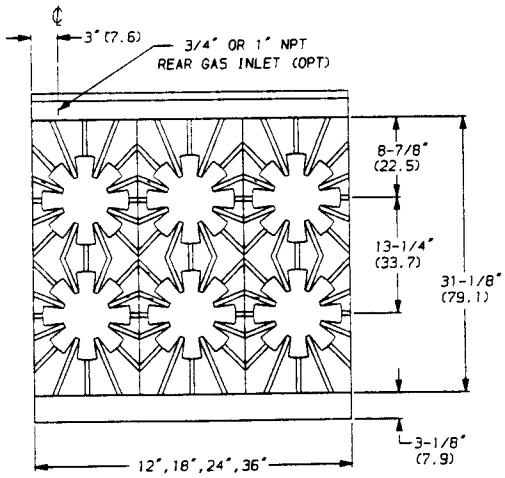

C36-5 TOP VIEW—
Shown: 6 open burners, 36" wide.

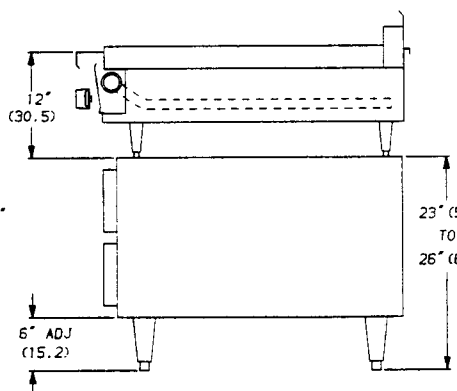

SIDE VIEW—
Shown with standard 4" legs.
Refrigerated base supplied by others.

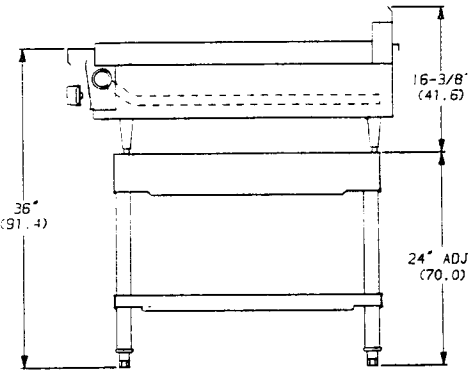

SIDE VIEW—
Shown with standard 4" legs.
Mounted on optional equipment stand.

IMPORTANT

Gas ranges must be installed in accordance with local codes or, in the absence of local codes, with the National Fuel Gas Code ANSI Z223.1. Compliance with codes is the responsibility of the Owner and Installer.

Adequate ventilation system required. Refer to The National Fire Protection Association Standard No 96, "Vapor Removal from Cooking Equipment".

Minimum Clearances:	Combustible Construction	Noncombustible Construction
Back Wall:	2"	0"
Left & Right Side:	6"	0"

With or without 4" legs: Must be installed on noncombustible counters only.

AGA Design Certified: In accordance with ANSI Z83.11 Gas Foodservice Equipment — Ranges. Note: These appliances are intended for commercial use by professionally trained personnel. *NOT Intended For Household Use.*

Montague's continuing commitment to quality / product improvement can cause specification and design changes without prior notice.

TYPE OF GAS		Natural 4.0" WC	Propane 10" WC
Model	# burners	TOTAL BTU/HR	TOTAL BTU/HR
C12-5	2	40,000	40,000
C12-559	2	35,000	35,000
C18-5A	2	40,000	40,000
C24-5	4	80,000	80,000
C24-559	4	70,000	70,000
C36-5	6	120,000	120,000
C36-559	6	105,000	105,000
C36-5A	4	80,000	80,000

GAS INLET SIZE (for all models):
1-1/4" front manifold with 1/2 union on each end provided for battery connection. Properly sized gas pressure regulator must be *Furnished By The Installer.*

Note: Specify type of gas Natural Propane
Specify elevation if installing above 2000 feet.

SHIPPING WEIGHT, (Lbs.): Class 85
C12-5 ...105 C24-5 ...260 C36-559 ...325
C12-559 ...115 C24-559 ...280 C36-5A ...272
C18-5A ...158 C36-5 ...300

ENTRY CLEARANCE, (uncrated): All models ...12"

APPROX. CUBIC FT., (crated):
C12 ... 4 C18 ... 5 C24 ... 7 C36 ... 10

