

MONTAGUE LEGEND



Heavy Duty Gas Chinese Range

GENERAL

All Chinese Ranges are custom designed. This specification covers the standard features and some of the options.

Model Designation:

Unit Prefix	Unit Suffix
CRM = Chinese Range, modular style	-1, -2, -3, etc. denotes number of woks.
CR = Chinese Range, enclosed base style	

Note: Ranges over 120" will be fabricated in two or more sections. Each section has a separate rear gas connection and 2" NPT rear drain. (Specify if range sections should drain to the left or the right.)

STANDARD FEATURES

RANGE TOPS:

- Stainless steel Top Plate and Fixed Cylinder, 10 ga. 304.
- Well Sections with double cylinder construction. Removable inner cylinder sets on retaining lugs inside the fixed cylinder. This unique well venting system carries escaping burner heat into a rear opening in the removable cylinder; ensures proper combustion and helps to prevent warping.
- One wok to fit each well section. (Bowls are 2" larger than the holes.) Specify wok size from left to right.
- 9" wide fixed Cutting Board / Plate Shelf, S/S.
- Full length Rear Drain Trough with Lift-out Strainer, 304 S/S.
- 12", 14", 16", 18" or 20" diameter Well Sections with pot supports may be used for SOUP POTS or woks. Used with 2-Ring burner rated @ 53,000 Btu/Hr. (Specify Soup Pot Well Section in-lieu-of wok.)
- Full length Perforated Copper Water line w/ Master Water Control Valve. (One valve required for each range section.)
- Swing Faucet, nickel plated brass, with Aerator. (One kit per wok). Use with cold water.
- 2" NPT Rear Drain is located on the left (unless otherwise specified).
- High temperature commercial-type burner valves and constant burning pilots used for automatic lighting. (Two valves / one pilot for 2-Ring Burner. Three valves / two pilots for 3-Ring Burner.)
- Master Gas Control Valve for Ring Burner (one per wok). Allows all 2-ring and 3-ring burners to be turned on / off simultaneously.
- S/S Pipe Overshelf for holding wok covers.
- Galvanized Drip Tray below each burner.

BURNERS:

- 2-Ring Cast Iron Burner, rated @ 53,000 Btu/Hr., furnished with 14", 16" and 18" diameter woks. (4-1/2" dia. Inner Ring: 15,000 Btu/Hr., 8" diameter Outer Ring: 38,000 Btu/Hr.)
- 3-Ring Cast Iron Burner, rated @ 107,000 Btu/Hr., furnished with 20", 22", 24", 26" and 28" diameter woks. (4-1/2" dia. Inner Ring: 15,000 Btu/Hr., 8" dia. Middle Ring: 38,000 Btu/Hr., 12" dia. Outer Ring: 54,000 Btu/Hr.)

Optional:

- Jet Burner - 20 Jet 80,000 Btu/Hr.
 32 Jet 120,000 Btu/Hr.

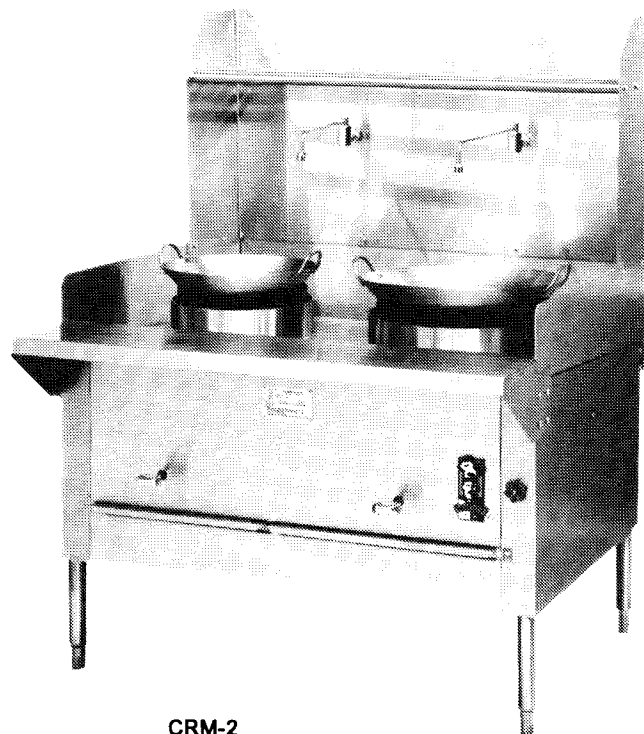

CRM-2
Shown with 14" and 16"
woks. Overall width 44".

STANDARD FEATURES, (cont.)

BASE:

- Modular Construction includes S/S Front, two sides, back. 12-1/2" S/S legs. (Specify prefix CRM).
- Optional:
 - Enclosed (cabinet-style). S/S Front, two sides, back and bottom shelf. 6" S/S legs. (Specify prefix CR).

FINISH

EXTERIOR:

All satin finish stainless steel exterior: Front, two sides, back and pipe shelf.

OPTIONS:

- Soup Pot well, in-lieu-of wok. (Specify well size.)
- Adaptor Ring for any size well section. (Reduces hole size for use with smaller woks.)
- S/S Spice Tray, 14" wide x 9-1/4" deep x 1-1/4" high. (fits over S/S cutting board/plate shelf.)
- Drip Tray, below each burner, 304, S/S.
- Woks, extra (Specify size)
- Wok Covers (Specify wok size)
- Knee level valve handle, (one per wok)
- Casters - 5" wheel, 6" height (for use w/standard modular construction or enclosed base.)
 - Set of 4 (Up to 48") Set of 6 (Up to 100")
 - Set of 8 (Up to 120")



Dimensions in parenthesis are centimeters.

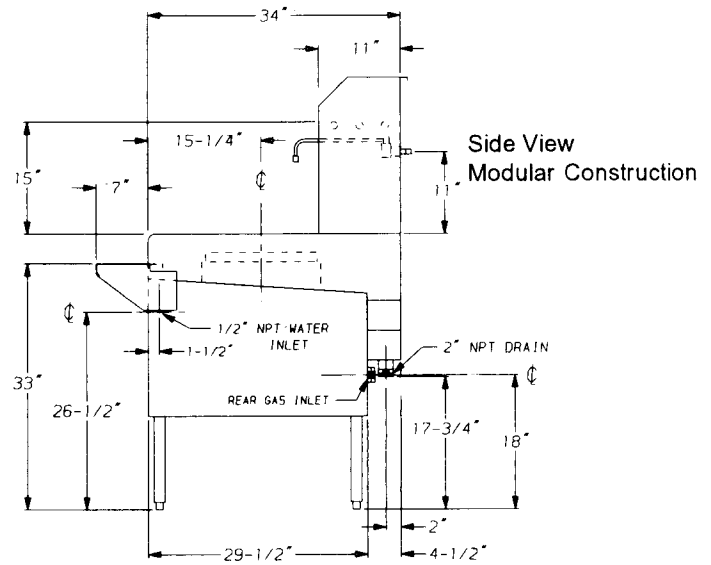
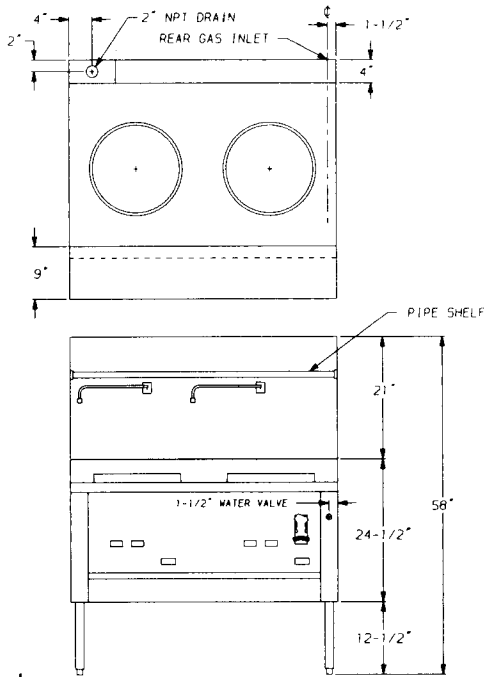

Top View

Side View
Modular Construction

Front View w/ Standard
Modular Construction

WOK SIZES (specify Left to Right)	14"	16"	18"	20"	22"	24"	26"	28"
Well Section, (Removable Cylinder)	12"	14"	16"	18"	20"	22"	24"	25"
Soup Pot Size	10"	12"	14"	16"	18"	N/A	N/A	N/A
Range Length per each Wok/Soup Pot	20"	22"	24"	26"	28"	30"	32"	34"
Ring Burner, standard	2-Ring	2-Ring	2-Ring	3-Ring	3-Ring	3-Ring	3-Ring	3-Ring
Btu/Hr - Wok	53,000	53,000	53,000	107,000	107,000	107,000	107,000	107,000
Btu/Hr - Soup Pot Well	53,000	53,000	53,000	53,000	53,000	N/A	N/A	N/A
Jet Burner, Optional	80,000	80,000	80,000	120,000	120,000	120,000	120,000	120,000

IMPORTANT

Commercial range(s) must be installed in accordance with local codes or, in the absence of local codes, with the National Fuel Gas Code ANSI Z223.1. Compliance with codes is the responsibility of the Owner and Installer.

Adequate Ventilation System required. Refer to the National Fire Protection Association Standard No.96, "Vapor Removal from Cooking Equipment".

AGA Design Certified: In accordance with ANSI Z83.11 Gas Foodservice Equipment - ranges. Note: These appliances are intended for commercial use by professionally trained personnel. *NOT Intended For Household Use.*

GAS CONNECTIONS:

REAR GAS INLET, with Gas Pressure Regulator properly sized, is provided:

Size	Btu/HR
1 - 3/4" NPT	Up to 360,000
1 - 1" NPT	Up to 560,000
2 - 1" NPT	Above 560,000

Note: Gas Pressure Regulator(s) are shipped loose and must be installed when appliance is connected to gas supply.

Note: Specify type of gas Natural Propane
Specify elevation if installing above 2000 feet.

ENTRY CLEARANCE: (all models, any length):
31-1/4" Uncrated

SHIPPING Weight: (class 85):
Approx. 150 lbs., per foot in length

Montague's continuing commitment to quality/product improvement can cause specification and design changes without prior notice.

Minimum Clearances:	Noncombustible Construction
Back Wall:	0"
Left & Right Side:	0"

