

Model 136-2

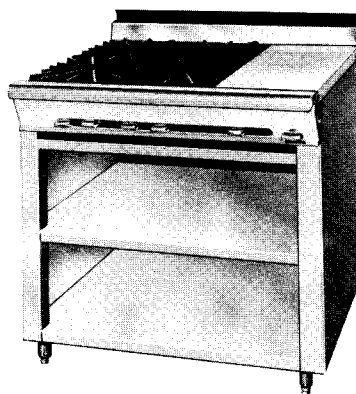

Model 36-2

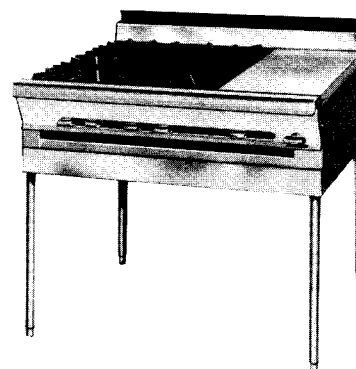

Model M36-2

Model Variations:

136-2 — Oven model with 6" legs.

36-2 — Cabinet model with 6" legs.

M36-2 — Countertop model with 28" high modular stand with S/S tubular legs.

C36-2 — Counter model

Open Tops: Two 12" wide x 31" deep heavily ribbed cast iron grates on left with four open burners. Each Star burner has individually raised ports to help prevent clogging from splillovers and for better combustion. Burners are rated at 20,000 BTU/HR each, with automatic constant burning pilots. Drip pan under open burners.

Options: *(extra cost):

- 59 top(s), rated @ 15,000 BTU/HR each, 12" wide x 31" deep cast iron top with heavily ribbed open burner grate across front and Solid Hot Top section across rear. Located:
 - 1, left 1, center 2, left and center

*Ribbon Grate, cast iron. (In-lieu-of 12" open burner grate.)

Note: For use with 20,000 BTU/HR burners. Located:

- *1, left *1, center *2, left and center
- *30,000 BTU/HR Star open burner for use with Natural gas:
 - *2, front *2, back *4, front and back

Solid Hot Top: One 12" wide x 31" deep cast iron Hot Top on right is front fired with one burner rated at 18,500 BTU/HR.

Optional:

- Even-Heat with one burner rated at 20,000 BTU/HR. Suffix E. Constructed with specially designed conduction studs for improved heat transfer and 2" integral flanges on front and sides. High temperature commercial-type burner valve and constant burning pilot is used for automatic lighting. An insulated partition to confine heat to each individual top configuration is furnished.

Oven Interior: The front venting oven is 26" wide x 28" deep x 15" high. Standard interior finish is porcelainized steel.

Options, *(extra cost):

- *Cast iron oven bottom

The 3-position rack guides and oven bottom are removable for major cleaning. The oven is heated by a cast iron burner

rated at 40,000 BTU/HR. The oven cavity is completely encased in high density fiberglass insulation maximizing heat retention. One rack with bright nickel finish is furnished.

Oven Controls: Includes manual burner valve, heavy duty throttling type thermostat, 100% safety pilot and automatic lighting. Controls are located in an insulated and vented compartment for longer life. Thermostat located on front right side. Thermostat dial has a temperature range from low to 500°F (260°C).

Oven Doors: Weight counterbalanced without the use of springs. One piece offset tubular-type handle is used.

Finish: Satin finish stainless steel front, including 4" flue riser. Remaining exterior black. All painted surfaces have electrolytic zinc undercoating for corrosion protection and longer life. Additional S/S finish available, *(extra cost):

- *S/S left side *S/S right side *S/S back panel
- *S/S lower shelves for cabinet base, (2 ea. required)

NOTE: Black finish with S/S trim available.

Options, *(extra cost):

- | | S/S front | Black |
|---|--------------------------|--------------------------|
| <input type="checkbox"/> *18" High Back: | <input type="checkbox"/> | <input type="checkbox"/> |
| <input type="checkbox"/> *Single High Shelf: | <input type="checkbox"/> | <input type="checkbox"/> |
| <input type="checkbox"/> *Double High Shelf: | <input type="checkbox"/> | <input type="checkbox"/> |
| <input type="checkbox"/> *Doors for Cabinet Base: | <input type="checkbox"/> | <input type="checkbox"/> |

*Extra Oven Racks

*42" Range Depth, suffix -40

*Left Rear Manifold with pressure regulator:

*3/4" NPT, up to 165,000 BTU/HR

*3/4" NPT, up to 320,000 BTU/HR

* 1" NPT, up to 500,000 BTU/HR

Cap, Manifold: left side right side

(Must specify when ordering.)

*S/S Cover, Manifold: left side right side

*Plate Shelf — 6" wide, S/S

*Casters — set of 4, 5" wheel, 6" height

*Flex Connector Kit — hose, disconnect and restraining device: *3' x 3/4" *4' x 3/4" *5' x 3/4"

*Security Options — i.e., prisons. Consult factory.

Exterior Dimensions: 36" wide x 36-5/8" deep. See drawing on reverse side for heights. For 42" depth add 6" to overall depth of range.



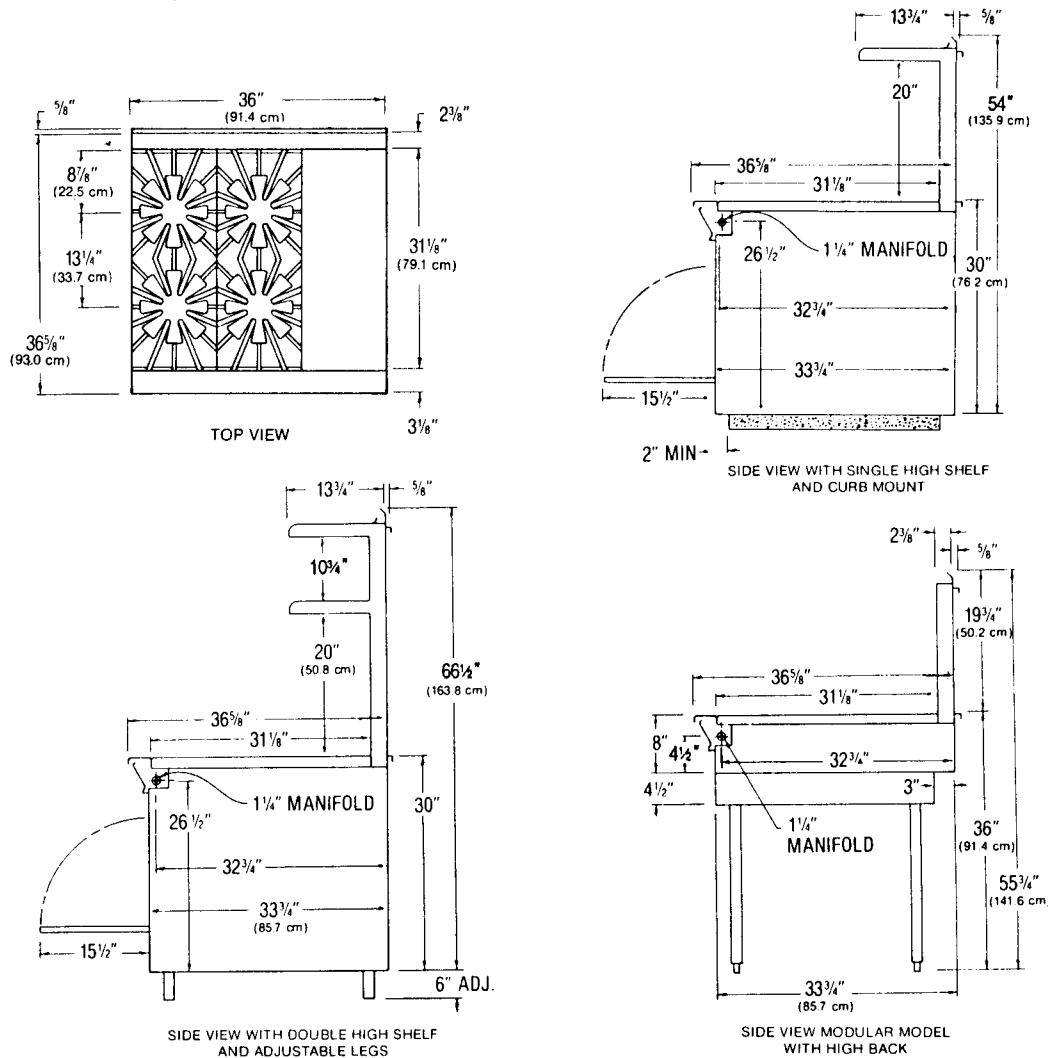

IMPORTANT:

Ranges must be installed in accordance with local codes or, in the absence of local codes, with the National Fuel Gas Code ANSI Z223.1. Compliance with codes is the responsibility of the Owner and Installer.

Adequate Ventilation System required. Refer to the National Fire Protection Association Standard No.96, "Vapor Removal from Cooking Equipment".

AGA Design Certified: in accordance with ANSI Z83.11 Gas Foodservice Equipment — Ranges. (Note: These appliances are intended for commercial use by professionally trained personnel. *NOT Intended For Household Use.*)

Minimum Clearances:	Combustible Construction	Noncombustible Construction
Back Wall:	2"	0"
Left & Right Side:	*6"	0"
With 6" legs: suitable for installation on combustible floors.		
Without legs: For use only on noncombustible floors.		
*15" when installed with 30,000 BTU/HR burners.		
Counter models: For use on noncombustible counters only.		

TYPE OF GAS		Natural 4.0" WC	Propane 10" WC
Model	# burners	BTU/HR	BTU/HR
136-2	6	138,500	138,500
36-2	5	98,500	98,500
C36-2	5	98,500	98,500
M36-2	5	98,500	98,500

Add 1,500 BTU/HR per Hot Top for Even-Heat option—suffix E. Add 10,000 BTU/HR for each 30,000 BTU/HR burner used. Deduct 5,000 BTU/HR for each -59 Open/Hot Top used.

GAS INLET SIZE (for all models):

1-1/4" front manifold with 1/2 union on each end provided for battery connection. Properly sized gas pressure regulator must be *Furnished By The Installer.*

Note: Specify type of gas Natural Propane
Specify elevation if installing above 2000 feet.

SHIPPING WEIGHT: *Class 77-1/2 **Class 85
136-2..... *566 lbs. C36-2.....**290 lbs.
36-2.....**390 lbs. M36-2.....**334 lbs.

ENTRY CLEARANCE: 30", all models, uncrated.

APPROX. CUBIC FT., (crated):

Cabinet base models. . . 27 Counter Models. . . 13

Montague's sole commitment to quality/product improvement can cause specification and design changes without prior notice.

