



Gas Heavy Duty Deluxe Griddle with Snap-Acting Thermostats



Deluxe Griddle
Model DG2448-SAT
Shown with optional
stand

GENERAL

A Heavy Duty gas-fired griddle designed for high production applications requiring rapid recovery and accurate temperature control. Units are available in widths of various increments from 24 inches to 72 inches.

STANDARD FEATURES/BENEFITS

Body: Modular chassis has welded angle and channel sub-frame for strength and rigidity. Exterior finish is stainless steel front and sides.

Griddle Plates: Standard plates are 1 inch thick ground and highly polished steel which requires no break-in. Actual cooking surface is 24 inches in depth. Stainless Steel splash is 4 inches high in the rear and the sides taper down level at the front. Stainless Steel trough is 3 ¼ inches in width.

Burners: One high capacity, 30,000 Btu, U shaped burner for every 12 inches of griddle plate enables rapid recovery. Each burner has a standing pilot equipped with a piezo igniter, is controlled by an individual thermostat and equipped with a safety pilot valve in the event of pilot outage.

Grease Drawer: Large 4 ½ quart capacity grease drawer with anti-splash baffle is accessible from the front of the unit. Units 48 inches and wider are equipped with two drawers.

Thermostats: One thermostat for each burner. Standard units with the SAT suffix are equipped with a "Snap-Action Thermostat". A SST suffix indicates the optional "Solid-State Thermostat".

Misc: ¾" NPT rear manifold connection, gas pressure regulator, 4 inch stainless steel adjustable legs and 6 foot power cord with 5-15 NEMA plug are standard.

TOP OPTIONS:

- Solid-State Thermostats (SST Model No. Suffix)
- Stainless Steel Back
- Chrome Finish Griddle Plate
- Integral Griddle Stand with S/S lower shelf and S/S legs
- Automatic pilot igniter- Electronically controlled spark ignites standing safety pilot.
- Open Burners: 2 (GC-2) or 4 (GC-4) 25,000 Btu burners available as a side-by-side unit with the griddle. Specify right or left.
- Casters



Dimensions in parenthesis are centimeters.

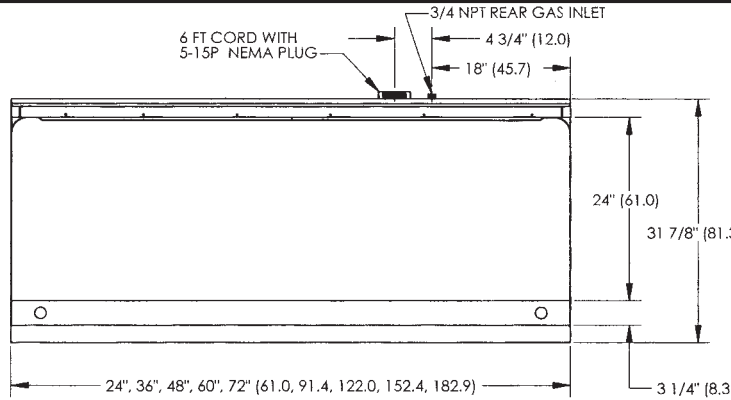

TOP VIEW

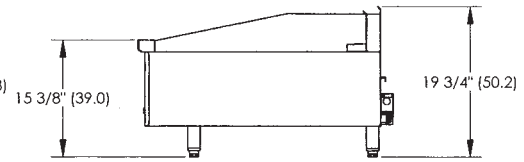

COUNTER MODEL w/4\"/>

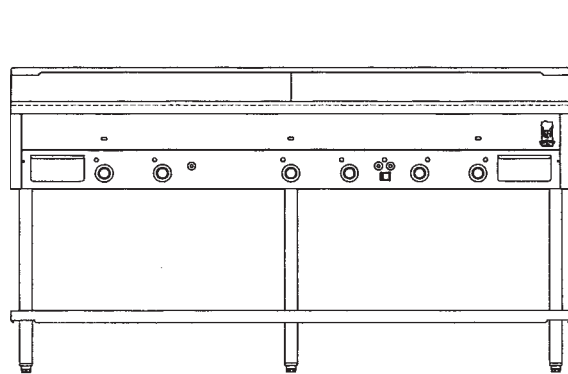

FRONT VIEW

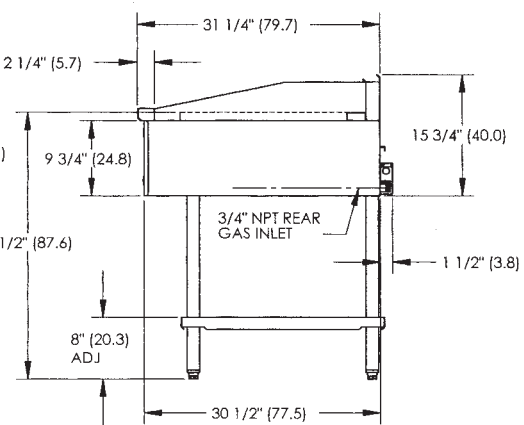

SHOWN W/OPTIONAL EQUIP STAND

IMPORTANT:

Commercial griddle(s) must be installed in accordance with local codes, or in the absence of local codes, with the National Fuel Gas Code, ANSI Z223.1, Natural Gas Installation Code, CAN/CGA-B149.1, or the Propane Installation Code, CAN/CGA-B149.2, as applicable. Compliance with codes is the responsibility of the Owner and Installer.

Adequate Ventilation System required. Refer to NFPA 96, Standard for Ventilation Control and Fire Protection of Commercial Cooking Operations.

Minimum Clearances:	Combustible Construction	Noncombustible Construction
Back	3"	0"
Left Side	2"	0"
Right Side	2"	0"
For installation on combustible floors with 24" high legs.		
For installation on non-combustible counters. with 4" high legs or custom stainless-steel base.		

AGA and CGA Design Certified: In accordance with ANSI Z83.11 CGA 1.8 - Food Service Equipment.

Note: These appliances are intended for commercial use by professionally trained personnel. *NOT Intended For Household Use.*

TYPE OF GAS	# of burners and T-stats	Natural 6.0" WC	Propane 10.0" WC	120V Power
		Total BTU/HR	Total BTU/HR	AMPS
DG2424-SAT	2	60,000	60,000	.2
DG2436-SAT	3	90,000	90,000	.4
DG2448-SAT	4	120,000	120,000	.5
DG2460-SAT	5	150,000	150,000	.6
DG2472-SAT	6	180,000	180,000	.7

GAS INLET SIZE (for all models):

3/4" (1.9 cm) NPT at right rear. 3/4" (1.9 cm) NPT gas pressure regulator is provided. Regulators must be installed when appliance is connected to gas supply.

NOTE: Specify type of gas Natural Propane
Specify elevation if installing above 2000 feet.

ENTRY CLEARANCE: 24" (61 cm) crated

SHIPPING WEIGHT: (Class 85)

DG2424-SAT	290 Lbs.	132 kg.
DG2436-SAT	402 Lbs.	182 kg.
DG2448-SAT	580 Lbs.	263 kg.
DG2460-SAT	692 Lbs.	314 kg.
DG2472-SAT	804 Lbs.	365 kg.

Montague's continuing commitment to quality/product improvement can cause specification and design changes without prior notice.



THE MONTAGUE COMPANY

1830 Stearman Avenue, P.O. Box 4954
Hayward, CA 94540-4954

Telephone: 800/345-1830 (outside CA)

510/785-8822 FAX: 510/785-3342

