



# LEGEND™ Heavy-Duty Gas Underfired Broilers — Radiant Style Free-Standing, Modular

Item No. \_\_\_\_\_

Project \_\_\_\_\_

Quantity \_\_\_\_\_

## UFSM-R Series



Model UFSM-30R shown

### SHORT/BID SPECIFICATION

Broiler shall be a Montague **Legend** Heavy-Duty Free-Standing, Modular Model:

UFSM- \_\_\_\_ R [Specify width]

...a gas-fired unit with 19,000 BTU/hr stainless steel tubular burners with individual controls, heating heavy-duty stainless steel radiant heat deflectors (radiants), with a full width debris screen under burners; two-position, reversible cast-iron ULTRA-FLOW top grates with both flat (wide) and narrow sides with ribbed grease troughs; a full width front grease trough and large capacity grease container located in cool zone; 4-1/2" (114mm) front/plate rail, 5-9/16" (141mm) high side and rear grease splash; mounted on a stainless steel stand with tubular legs; plus all the features listed and options/accessories checked:

### BURNER/RADIANT SYSTEM FEATURES:

- 19,000 BTU/hr stainless steel tubular burners
- Individual manual gas valves for zoned heat control
- Standing pilot for automatic ignition
- Heavy stainless steel radiants glow red for infrared broiling
- Removable self-cleaning radiants
- Full width debris screen under burners
- Full width removable drip tray
- Radiants and drip tray heat shields to reduce flare-ups

### TOP-GRATE FEATURES:

- Reversible ULTRA-FLOW cast iron grate sections
- Ribbed side for narrow marking, with side grease troughs
- Flat side for broiling fish and wide marking
- 1" (25mm) ribbed grate spacing for consistent grilling results
- Three-position grid frame for adjustment from flat to 3" (76mm) raised-rear
- Three-position easy-lift grate mechanism
- Sloped grates and side grate grease troughs reduce flare-ups

MODEL GUIDE				
✓	Model No.	Overall Width	Grates	Cooking Area
	UFSM-24R	24" (610mm)	3	18" x 24" (457 x 610mm)
	UFSM-30R	30" (762mm)	4	24" x 24" (610 x 610mm)
	UFSM-36R	36" (914mm)	5	30" x 24" (762 x 610mm)
	UFSM-48R	48" (1219mm)	6	36" x 24" (914 x 610mm)
	UFSM-60R	60" (1524mm)	8	48" x 24" (1219 x 610mm)
	UFSM-72R	72" (1829mm)	10	60" x 24" (1524 x 610mm)

### STANDARD CONSTRUCTION FEATURES:

- Satin finish stainless steel front & top trim with 4-1/2" (114mm) deep front rail
- 5-9/16" (141mm) high stainless steel side and rear splash
- Other surfaces painted black with electrolytic zinc undercoating
- Full width front grease trough for easy transfer
- Removable large capacity grease container
- 3/4" NPT rear gas manifold connection
- Stainless steel stand with tubular legs & adjustable bullet feet

### AGENCY APPROVALS

- NSF Listed
- CSA Design Certified to ANSI Z83.11 • CSA 1.8
- CE Approved EN 203-1



HDB-9 [Rev. 1/12]

# LEGEND™ Heavy-Duty Gas Underfired Broiler — Radiant Style Free-Standing, Modular

Item No. \_\_\_\_\_

Project \_\_\_\_\_

Quantity \_\_\_\_\_

## UFSM-R Series

Dimensions in brackets are millimeters

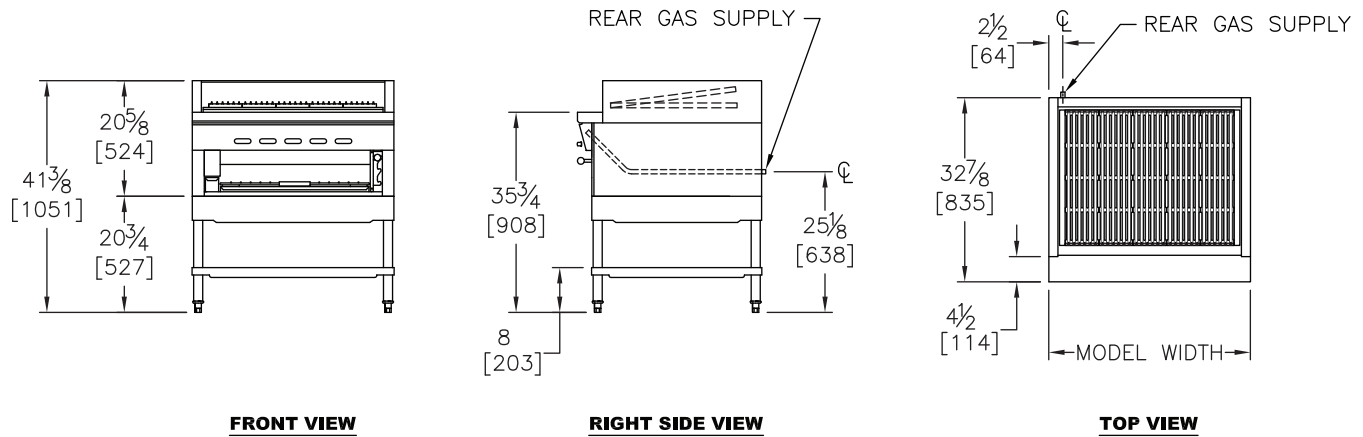

### OPTIONS GUIDE:

#### General:

- Removable splash guard, stainless steel
- Lower Warming Rack
- Casters — set of four/six 5" (127mm) casters
- Flex Connector Kit  
[3/4"] or [1"] NPT:

#### Grates & Radiants:

- Seafood grates, cast iron
- Round rod grates — 6" (152mm) sections:
  - Hard chrome
  - Cold rolled steel
- Scraper/cleaner for round rod grates
- Cast iron radiants — in place of stainless steel
- 3' (914mm) long  4' (1219mm) long

#### Finishes:

- Stainless steel left side panel
- Stainless steel right side panel

#### International Approvals:

- CE-Conformite Europeene  
*Includes Flame Failure Valve Option*
- Canadian Approval

### INSTALLATION REQUIREMENTS & SHIPPING INFORMATION

- Broilers must be installed in accordance with local codes or in their absence with the National Fuel Gas Code: ANSI Z223.1; Natural Fuel Gas Code: CAN/CGA-B149.1 or Propane Installation Code: CAN/CGA-B149.2, as applicable. Compliance with codes is the responsibility of the Owner and Installer.
- An adequate ventilation system is required. Refer to National Fire Protection Association Standard No. 96, "Standard for Ventilation and Fire Protection of Commercial Cooking Operations."
- This appliance is intended for commercial use by professionally trained personnel. NOT intended for Residential Use.
- Specify installation elevation: \_\_\_\_\_ if above 2000 feet (610m).
- GAS INLET SIZE (All Models): 3/4" NPT left rear inlet provided. A 3/4" NPT gas pressure regulator is provided and must be installed (by others) when unit is connected to gas supply.
- The incoming gas line pressure into the regulator should be 8"-14" w.c. for natural gas, and 12"-14" w.c. for propane gas.

Minimum Clearances	Noncombustible Construction
From Back Wall	0"
Left & Right Side	0"
<b>For use in noncombustible locations only.</b>	

Models:	Specify Type of Gas:	Manifold Pressure:		Shipping Weight	Shipping Class	Cube (Crated) ft <sup>3</sup> /m <sup>3</sup>
		6.0" WC	10.0" WC			
Burners		BTU/hr (kW)	BTU/hr (kW)			
UFSM-24R	<input type="checkbox"/> Natural	4	76,000 (22.3)	357 lbs (162 kg)	85	14/.4
UFSM-30R	<input type="checkbox"/> Propane	5	95,000 (27.8)	389 lbs (176 kg)	85	16/.5
UFSM-36R		6	114,000 (33.4)	420 lbs (190 kg)	85	21/.6
UFSM-48R		8	152,000 (44.6)	713 lbs (323 kg)	85	28/.8
UFSM-60R		10	190,000 (55.7)	775 lbs (351 kg)	85	35/1
UFSM-72R		12	228,000 (66.8)	838 lbs (380 kg)	85	41/1.2



## THE MONTAGUE COMPANY

1830 Stearman Avenue, Hayward, CA 94545

800 345-1830 • Fax: 510 785-3342

www.montaguecompany.com

Due to continuous product improvements, specifications are subject to change without notice.



HDB-9 [Rev. 1/12]