



LEGEND™ Heavy-Duty Gas Underfired Broilers – Radiant Style Range Match Cabinet Base

Item No. _____

Project _____

Quantity _____

UF-R Series



Model UF-24R shown, with optional lower warming rack

SHORT/BID SPECIFICATION

Broiler shall be a Montague **Legend** Heavy-Duty Range-Match Cabinet Base Model:

UF- ____ R [Specify width]:

...a gas-fired unit with 19,000 BTU/hr stainless steel tubular burners with individual controls, heating heavy-duty stainless steel radiant heat deflectors (radiants), with a full width debris screen under burners; two-position, reversible cast-iron ULTRA-FLOW top grates with both flat (wide) and ribbed sides (narrow with grease troughs); a full width front grease trough and large capacity grease container located in cool zone; 6" (152mm) front/plate rail, 5-9/16" (141mm) high side and rear grease splash mounted on a stainless steel cabinet base with 6" (152mm) legs as standard; plus all the features listed and options/accessories checked:

BURNER/RADIANT SYSTEM FEATURES:

- 19,000 BTU/hr stainless steel tubular burners
- Individual manual gas valves for zoned heat control
- Standing pilot for automatic ignition
- Heavy-duty stainless steel radiants glow red for infrared broiling
- Removable self-cleaning radiants
- Full width debris screen under burners
- Full width removable drip tray
- Radiants and drip tray heat shields to reduce flare-ups

MODEL GUIDE				
✓	Model No.	Overall Width	Grates	Cooking Area
	UF-18R*	18" (457mm)	3	12" x 24" (305 x 610mm)
	UF-24R	24" (610mm)	3	18" x 24" (457 x 610mm)
	UF-30R	30" (762mm)	4	24" x 24" (610 x 610mm)
	UF-36R	36" (914mm)	5	30" x 24" (762 x 610mm)
	UF-48R	48" (1219mm)	7	42" x 24" (1066 x 610mm)
	UF-60R	60" (1524mm)	8	48" x 24" (1219 x 610mm)
	UF-72R	72" (1829mm)	10	60" x 24" (1524 x 610mm)
*For battery installations only				

TOP-GRATE FEATURES:

- Reversible ULTRA-FLOW cast-iron grate sections
- Ribbed side for narrow marking, with side grease troughs
- Flat side for broiling fish and wide marking
- 1" (25mm) ribbed grate spacing for consistent grilling results
- Three-position grid frame for adjustment from flat to 3" (76mm) raised-rear
- Sloped grates and side grate grease troughs to reduce flare-ups

STANDARD CONSTRUCTION FEATURES:

- Satin finish stainless steel front & top trim with 6" (152mm) deep front rail
- 5-9/16" (141mm) high stainless steel side and rear splash
- Enclosed cabinet base with 6" (152mm) adjustable stainless steel legs
- Other surfaces painted black with electrolytic zinc undercoating
- Full width front grease trough for easy transfer
- Removable large capacity grease container
- 1-1/4" NPT front gas manifold with 1/2 union on each end
- UF-18R for battery installations only (Refer to page HDB-1 for features)

AGENCY APPROVALS

- NSF Listed
- CSA Design Certified to ANSI Z83.11 • CSA 1.8
- CE Approved EN 203-1



HDB-3 [Rev. 1/12]

LEGEND™ Heavy-Duty Gas Underfired Broilers — Radiant Style Range Match Cabinet Base

Item No. _____

Project _____

Quantity _____

UF-R Series

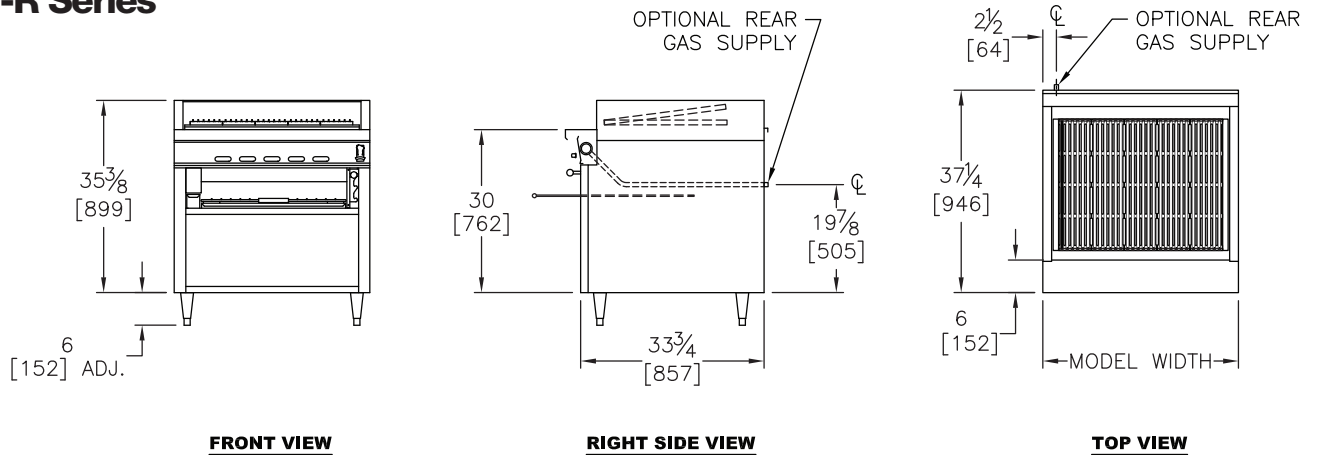

OPTIONS GUIDE:

General:

- 42" (1067mm) unit depth (Suffix -40)
[Same grid size]
- Casters — set of four/six 5" (127mm) casters
- Flex Connector Kit [1" NPT]:**
 - 3' (914mm) long
 - 4' (1219mm) long
- 15" (330mm) High Back
[Matches 18" (457mm) range back]:
 - stainless steel
 - black
- Curb Mounting
- Lower Warming Rack
- Removable splash guard, stainless steel

Manifolds: [Left rear, with pressure regulator]:

- 1" NPT
- Manifold Cap:** left side right side

Stainless Manifold Cover: left side right side

Grates, Radiants, Plate Shelves

- Seafood grates, cast iron
- Round rod grates — 6" (152mm) sections:
 - Hard chrome
 - Cold rolled steel
- Scraper/cleaner for round rod grates
- Cast iron radiants — in place of stainless steel
- Wider Plate Shelf:
 - 9" (229mm)
 - 11" (279mm)
- Plate Shelf Cutouts [for 11" (279mm) only]:

Specify: 1/6 pans or 1/4 pans or 1/9 pans number: __ ea.

Finish/Cabinet Upgrades:

- Stainless steel left side panel
- Stainless steel right side panel
- Stainless steel back panel
- Stainless steel bottom cabinet shelf
- Stainless steel cabinet base doors

International Approvals:

- CE-Conformite Europeene
Includes Flame Failure Valve Option
- Canadian Approval

INSTALLATION REQUIREMENTS & SHIPPING INFORMATION

- Broilers must be installed in accordance with local codes or in their absence with the National Fuel Gas Code: ANSI Z223.1; Natural Fuel Gas Code: CAN/CGA-B149.1 or Propane Installation Code: CAN/CGA-B149.2, as applicable. Compliance with codes is the responsibility of the Owner and Installer.
- An adequate ventilation system is required. Refer to National Fire Protection Association Standard No. 96, "Standard for Ventilation and Fire Protection of Commercial Cooking Operations."
- This appliance is intended for commercial use by professionally trained personnel. NOT intended for Residential Use.
- Specify installation elevation: _____ if above 2000 feet (610m).
- GAS INLET SIZE (All Models):** 1-1/4" NPT front manifold with 1/2 union on each end provided for battery connection. A properly sized gas pressure regulator must be furnished by the Installer. With 1" rear inlets, a gas pressure regulator is provided and must be installed (by others) when unit is connected to gas supply.
- The incoming gas line pressure into the regulator should be 8"-14" w.c. for natural gas, and 12"-14" w.c. for propane gas.

Minimum Clearances	Noncombustible Construction
From Back Wall	0"
Left & Right Side	0"
For use in noncombustible locations only.	

Models:	Specify Type of Gas: Manifold Pressure: Burners	<input type="checkbox"/> Natural	<input type="checkbox"/> Propane	Shipping Weight	Shipping Class	Cube (Crated) ft ³ /m ³
		6.0" WC	10.0" WC			
		BTU/hr (kW)	BTU/hr (kW)			
UF-18R	2	38,000 (11.1)	38,000 (11.1)	160 lbs (73 kg)	85	13/.4
UF-24R	4	76,000 (22.3)	76,000 (22.3)	372 lbs (169 kg)	85	21/.6
UF-30R	5	95,000 (27.8)	95,000 (27.8)	402 lbs (182 kg)	85	32/.9
UF-36R	6	114,000 (33.4)	114,000 (33.4)	432 lbs (196 kg)	85	32/.9
UF-48R	8	152,000 (44.5)	152,000 (44.5)	744 lbs (337 kg)	85	46/1.3
UF-60R	10	190,000 (61.2)	190,000 (61.2)	804 lbs (364 kg)	85	65/1.8
UF-72R	12	228,000 (55.7)	228,000 (55.7)	864 lbs (391 kg)	85	65/1.8

Due to continuous product improvements, specifications are subject to change without notice.



THE MONTAGUE COMPANY

1830 Stearman Avenue, Hayward, CA 94545

800 345-1830 • Fax: 510 785-3342

www.montaguecompany.com



HDB-3 [Rev. 1/12]