



MONTAGUE  
**TECHNOSTAR**

# Medium-Duty 72" (1829mm) Counter-Top Range Models

Item No. \_\_\_\_\_

Project \_\_\_\_\_

Quantity \_\_\_\_\_

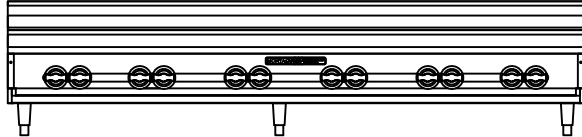

## SHORT/BID SPECIFICATION

Range shall be a Montague *Technostar* Countertop Model:

- TC-12**, with twelve 12" (305mm) cast iron open top grates, over two 30,000 BTU/hr cast iron burners each, with individual burner controls and automatic standing pilot
- TC-10-1FT**, with ten 12" (305mm) cast iron open top grates, over two 30,000 BTU/hr cast iron burners each and one 12" (305mm) wide 1/2" (13mm) thick frytop each with one 20,000 BTU/hr burner, with individual burner controls and automatic standing pilots
- TC-8-2FT**, with eight 12" (305mm) cast iron open top grates, over two 30,000 BTU/hr cast iron burners each, and one 24" (610mm) wide 1/2" (13mm) thick frytop with two 20,000 BTU/hr burner, individual burner controls and automatic standing pilots
- TC-6-3FT**, with six 12" (305mm) cast iron open top grates, over two 30,000 BTU/hr cast iron burners each, and one 36" (914mm) wide 3/4" (19mm) thick frytop with three 20,000 BTU/hr burner, individual burner controls and automatic standing pilots
- TC-4-4FT**, with four 12" (305mm) cast iron open top grates, over two 30,000 BTU/hr cast iron burners each, and one 48" (1219mm) wide 3/4" (19mm) thick frytop with four 20,000 BTU/hr burners, individual burner controls and automatic standing pilots
- TC-2-5FT**, with two 12" (305mm) cast iron open top grate, over two 30,000 BTU/hr cast iron burners each, and one 60" (1524mm) wide 3/4" (19mm) thick frytop with five 20,000 BTU/hr burners, individual burner controls and automatic standing pilots
- TC-6FT**, with one 72" (1829mm) wide 3/4" (19mm) thick frytop with six 20,000 BTU/hr burners, individual burner controls and automatic standing pilots;

...mounted on 8" (203mm) high base with stainless steel front and sides, 3" (76mm) deep front rail, 4" (102mm) high rear flue riser and 4" (102mm) stainless steel legs standard; plus all the features listed and options/accessories checked:

MODEL GUIDE		
✓	Model No.	Top Configuration
	TC-12	Twelve 12" (305mm) Open Burners
	TC-10-1FT	Ten 12" (305mm) Open Burners & 12" (305mm) Fry Top
	TC-8-2FT	Eight 12" (305mm) Open Burners & 24" (610mm) Fry Top
	TC-6-3FT	Six 12" (305mm) Open Burners & 36" (914mm) Fry Top
	TC-4-4FT	Four 12" (305mm) Open Burners & 48" (1219mm) Fry Top
	TC-2-5FT	Two 12" (305mm) Open Burners & 60" (1524mm) Fry Top
	TC-6FT	72" (1829mm) Fry top

## TECHNOSTAR TOP FEATURES:

*Open Burner Sections* are 12" wide x 27" deep (305 x 686mm) with:

- One-piece cast iron, surface-ground top grates
- Two 25,000 BTU/hr cast iron mushroom-head burners with side ports and spillover lip
- Automatic, standing pilots
- Drip pans positioned under burners

*Frytop (Griddle) Sections* are: 12" (305mm)[-1FT], 24" (610mm) [-2FT], 36" (914mm)[-3FT], 48" (1219mm) [-4FT], 60" (1524mm) [-5FT] or 72" (1829mm) [-6FT]: wide and 22" (559mm) deep, with:

- 1/2" (13mm) thick [-1FT & -2FT] or 3/4" (19mm) thick [-3FT and larger] precision-ground steel cook surface
- 2" (51mm) high backsplash and tapered side-splashes
- 2-5/8" (67mm) wide front grease gutter with drop to: built-in grease drawer
- One 20,000 BTU/hr gas burner with standing pilots & gas control valve, per 12" (305mm) section
- Adjusting bolts for changing top plate forward pitch

## STANDARD BASE CONSTRUCTION FEATURES:

- Satin finish stainless steel front and sides with 3" (76mm) deep front rail
- Stainless steel 4" (102mm) rear flue riser
- 4" (102mm) height-adjustable stainless steel legs
- 3/4" gas pressure regulator is provided as standard

## STANDARD WARRANTY:

- One Year, Parts & Labor

## AGENCY APPROVALS

- NSF Listed
- CSA Design Certified to ANSI Z83.11 • CSA 1.8
- CE Approved • EN 437



HDCS-5 [Rev. 7/11]

# Medium-Duty 72" (1829mm) Counter-Top Range Models

Item No. \_\_\_\_\_

Project \_\_\_\_\_

Quantity \_\_\_\_\_

Dimensions in brackets are millimeters

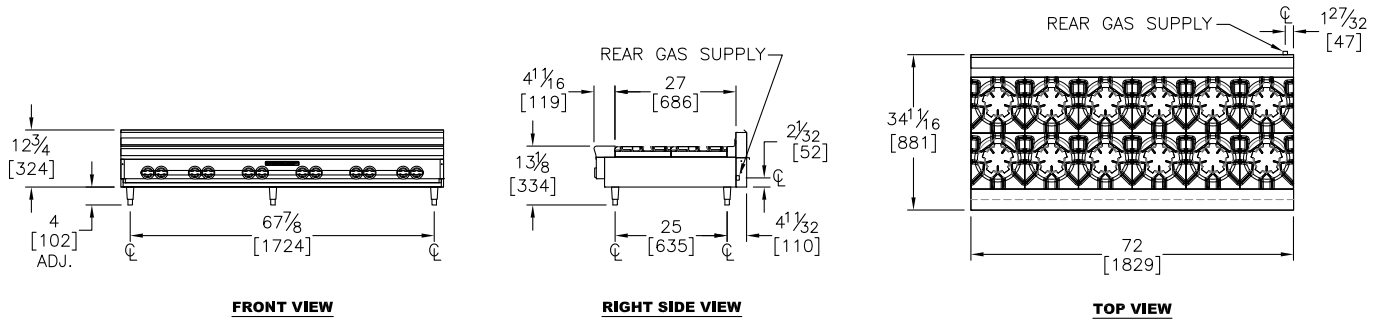

### OPTIONS GUIDE:

#### For Frytop (Griddle) Sections:

- Mount Frytop on left [Add to Suffix: -FTL] Adds 2" (51mm) to width for grease container
- 3/4" (19mm) thick plate for 1ft or 2 ft options
- 1" (25mm) thick plate
- Thermostat control(s) [Add to Suffix: -FTT]
- 4" (102mm) removable side splash:
  - left
  - right

#### General:

- Substitute Work Surface Top for Open Burners —  
Use Suffix: **-\_\_WS** [Specify number: 1, 2, etc.]
- Substitute Hot Top for Open Burners —  
Use Suffix: **-\_\_HT** [Specify number: 1, 2, etc.]
- Stainless steel back panel

#### International Approvals:

- CE - Conformance Européenne - EN203-1  
*Includes flame failure valve option*
- Canadian Approval

### INSTALLATION REQUIREMENTS & SHIPPING INFORMATION

- Range must be installed in accordance with local codes or in their absence with the National Fuel Gas Code: ANSI Z223.1. Compliance with codes is the responsibility of the Owner and Installer.
- An adequate ventilation system is required. Refer to National Fire Protection Association Standard No. 96, "Vapor Removal from Cooking Equipment."
- This appliance is intended for commercial use by professionally trained personnel. NOT intended for Residential Use.
- Specify installation elevation:** \_\_\_\_\_ if above 2000 feet (610m).
- GAS INLET SIZE (All Models):** 1" NPT at right rear. 1" NPT gas pressure regulator is provided. The gas supply pressure to the regulator must be 8"-14" WC for natural gas or 12"-14" WC for propane gas. Consult factory for different gas types and pressures.

Minimum Clearances	Combustible Construction	Noncombustible Construction
From Back Wall	2" (51mm)	0"
Left & Right Side	11" (279mm)	0"
With or without 4" (102mm) legs	Suitable for installation on non-combustible counters ONLY	

Models:	Specify Type of Gas: Manifold Pressure: Burners	<input type="checkbox"/> Natural	<input type="checkbox"/> Propane	Shipping Weight	Shipping Class	Cube (Crated) ft <sup>3</sup> /m <sup>3</sup>
		6.0" WC BTU/hr (kW)	10.0" WC BTU/hr (kW)			
TC-12	12	300,000 (87.9)	240,000 (87.9)	410 lbs (186 kg)	70	28/.8
TC-10-1FT	11	270,000 (79.1)	220,000 (79.1)	426 lbs (193 kg)	70	28/.8
TC-8-2FT	10	240,000 (70.3)	200,000 (70.3)	438 lbs (199 kg)	70	28/.8
TC-6-3FT	9	210,000 (61.5)	180,000 (61.5)	506 lbs (229 kg)	70	28/.8
TC-4-4FT	8	180,000 (52.7)	160,000 (52.7)	539 lbs (244 kg)	70	28/.8
TC-2-5FT	7	150,000 (43.9)	140,000 (43.9)	571 lbs (259 kg)	70	28/.8
TC-6FT	6	120,000 (35.2)	120,000 (35.2)	604 lbs (274 kg)	70	28/.8



## THE MONTAGUE COMPANY

1830 Stearman Avenue, Hayward, CA 94545  
 800 345-1830 • Fax: 510 785-3342  
[www.montaguecompany.com](http://www.montaguecompany.com)

Due to continuous product improvements, specifications are subject to change without notice.

