



VECTAIRE™ Double Deck, Full-Size Bakery Depth Electric Convection Ovens

Item No. _____

Project _____

Quantity _____

SLEK2-15 Series



Model SLEK2-15AP Shown with optional casters

SHORT/BID SPECIFICATION

Convection oven shall be a Montague *Vectaire* double deck full-size electric Model:

- SLEK2-15 bakery depth 15-kW** units with 6" (152mm) stainless steel legs
- [Specify controls]:
- AH, Cook-n-Hold Controls** with: solid state 150-500°F (66-260°C) thermostat with RTD platinum temperature sensor, 24-hour digital countdown timer with alarm, programmable HOLD feature and burner-ON indicator light
- AP, Programmable Controls** with: five-button menu pad, plus all Cook-n-Hold Controls including: solid state 150-500°F (66-260°C) thermostat with RTD platinum temperature sensor, 24-hour digital countdown timer with alarm, programmable HOLD feature and burner-ON indicator light

...with three tubular heating elements in one group of three (each deck); porcelainized steel oven interiors with one-speed [bakery] or two-speed [standard] fans; nine rack positions, five bright nickel racks with rack stops and no-tip guides standard; two 50-50 stainless steel doors with double pane viewing windows; plus all the features listed and options/accessories checked:

MODEL-PAN/RACK GUIDE (For Each Deck):

✓	Model No.	Oven Depth	Racks/Positions	Rack Spacing	
				5-racks	9-racks
	SLEK2-15	Bakery*	5/9	3-3/8" (86mm)	1-1/2" (38mm)

*18" x 26" (457 x 660mm) sheet pans length or sideways

OVEN INTERIOR CONSTRUCTION [EACH DECK]:

- Porcelainized steel cooking compartment
- Nine-position bright nickel rack guides
- Five bright nickel pan racks, with rack-stop and no-tip guides standard
- Two covered interior lights
- 4" (102mm) of insulation compressed to 2" (51mm) with metal sheathing

HEATING ELEMENTS & BLOWER SYSTEM [EACH DECK]:

- Six 2.5-kW heating elements grouped in two sets
- Blower with 3/4-horsepower single-speed motor

EXTERIOR CONSTRUCTION FEATURES:

- Satin finish stainless steel front, sides & top
- Black painted steel back
- Ball bearing mounted 50-50 double door
- Double pane thermal viewing windows
- Tubular grab-bar handle with insulated comfort grip
- Durable, adjustable door gasket
- 6" (152mm) legs stainless steel legs with adjustable bullet feet

CONTROL FEATURES [EACH DECK]:

- Power-ON switch
- Oven-ON indicator light
- Moisture vent
- Cook-n-Hold -AH Package:**
 - Solid state 150-500°F (66-260°C) thermostat
 - Programmable 140-200°F (63-93°C) HOLD feature
 - Precise RTD platinum temperature probe
 - 24-hour digital countdown timer with alarm
 - Up to 20 min. pulsed fan intervals (IFO)
- Programmable-AP Package:**
 - Five button programmable menu pad, plus:
 - Solid state 150-500°F (66-260°C) thermostat
 - Programmable 140-200°F (63-93°C) HOLD feature
 - Precise RTD platinum temperature probe
 - 24-hour digital countdown timer with alarm
 - Up to 20 min. pulsed fan intervals (IFO)

AGENCY APPROVALS

- NSF Listed
- UL Listed (ANSI/UL-197)



VC0-14 [Rev. 1/12]

VECTAIRE™ Double Deck, Full-Size Bakery Depth Electric Convection Ovens

Item No. _____

Project _____

Quantity _____

SLEK2-15 Series

Dimensions in brackets are millimeters

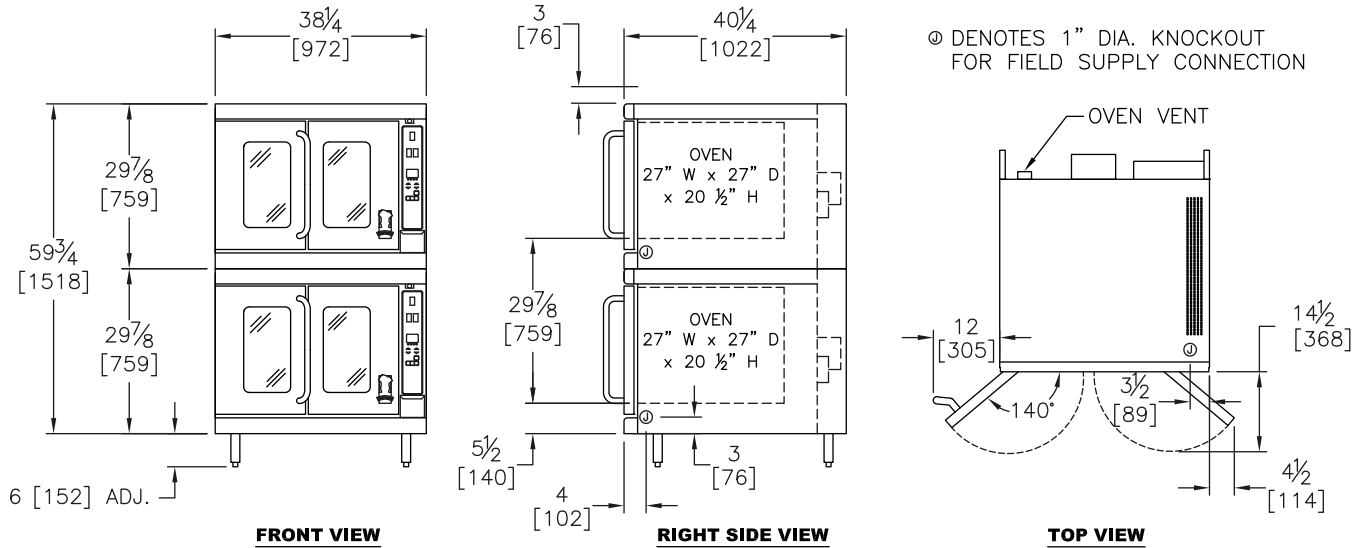

OPTIONS GUIDE:

Installation Alternatives:

- Casters [Set of four]:
 - 4" (102mm)
 - 6" (152mm)
- Casters [Set of four 5" (127mm) plate casters]
- 1" (25mm) Toe Base for curb mounting
- Heat Shield Kit -[see minimum clearances]

Controls & Motor Alternatives:

- Two speed fan motor [for SLEK2-15, 1-pH only]

Finish:

- Full stainless steel oven interiors [-ASC suffix]
- Stainless steel louvered back panel
- Stainless steel exterior bottom

Racks & Security:

- Stainless steel drip tray: ____ ea.
- Extra Racks: ____ ea. std.; ____ ea. heavy duty
- 11-position rack guides [set of two]: ____ ea.
- Solid Doors [in place of windows]
- Security Options [Consult Factory]

INSTALLATION REQUIREMENTS & SHIPPING INFORMATION

- Oven must be installed in accordance with local codes or in their absence with the National Electric Code: ANSI/NFPA 70. Compliance with codes is the responsibility of the Owner and Installer.
- Each oven deck requires a separate electric power connection. A 1" (25mm) knockout is provided.
- An adequate ventilation system is required. Refer to National Fire Protection Association Standard No. 96, "Vapor Removal from Cooking Equipment."
- This appliance is intended for commercial use by professionally trained personnel. NOT intended for Residential Use.

Minimum Clearances	Combustible Construction	Noncombustible Construction
From Back Wall	0"	0"
Left & Right Side*	0"	0"
Unit must be mounted on legs, cabinet or stand.		

Electric Requirements*

Voltage	Phase	Hz	Total kW	Nominal AMP/Line			Minimum Circuit Capacity
			SLEK2-15	L1	L2	L3	
208	1	60	12.00	78			98
240	1	60	12.00	69			98
208	3	60	12.00	43	43	41	54
240	3	60	12.00	40	40	36	54
480	3	60	12.00	22	22	19	27

*Other Voltage/Hz models available. Contact factory.

Shipping Information:

Models	Weight	Shipping Class	Cube (Crated) ft ³ /m ³
SLEK2-15 [all]	930 lbs (421 kg)	70	2 X 37/1
Entry clearance 30" (762mm) uncrated			

Due to continuous product improvements, specifications are subject to change without notice.



THE MONTAGUE COMPANY

1830 Stearman Avenue, Hayward, CA 94545
 800 345-1830 • Fax: 510 785-3342
 www.montaguecompany.com



VC0-14 [Rev. 1/12]