



LEGEND™ Heavy-Duty Range Match Gas Fryers

Item No. _____

Project _____

Quantity _____



Model RF40

SHORT/BID SPECIFICATION

Fryer shall be a Montague **Legend** Range Match Model [Specify one]:

- RF40**, an 18" (457mm) wide unit with a unique 110,000 BTU/hr burner and a single 40 pound oil capacity frypot
- RF240**, a 36" (914mm) wide unit with two 110,000 BTU/hr burners with twin 40 pound oil capacity frypots
- RD18**, an 18" (457mm) wide matching fry basket drain cabinet; ...with satin finished stainless steel front, cabinet access door(s), bottom and sides; two 5-1/2" (140mm) wide fry baskets per frypot and removable stainless steel basket hangers; 6" (152mm) height adjustable legs and 11" (279mm) high flue riser standard; plus all the features listed and options/accessories checked:

STANDARD CONSTRUCTION FEATURES:

- Satin finish stainless steel front, sides & bottom
- Hinged stainless steel door(s) provides easy access to controls
- Other surfaces painted black
- Welded stainless steel frypot with deep cool zone
- 1" (25mm) ball-type front drain valve, with extension pipe standard
- Twin wire fry baskets with insulated handles
- Sturdy, removable, stainless steel basket hangers
- 11" (279mm) high flue riser with insulated heat shield for cooler operation
- 6" (152mm) height-adjustable stainless steel legs
- 1-1/4" NPT front gas manifold with 1/2 unions for battery connection

MODEL GUIDE

✓	Model No.	Overall Width	Tanks	Shortening Capacity
	RF40	18" (457mm)	1	40 lb (18 kg)
	RF240	36" (914mm)	2	80 lb (36 kg)
	RD18	18" (457mm)	Basket Drain Cabinet	

BURNERS & CONTROLS:

- Stainless steel atmospheric 55,000 BTU/hr burners
- Self-powered 200-375°F (93-190°C) thermostat-gas valve
- Automatic ignition safety pilot
- High temp limit control & built-in gas pressure regulator

RD18 DRAIN CABINET [ONLY]

- Matching cabinet with hinged door
- Stainless steel perforated lift out top screen
- Stainless steel slide-out grease catch pan

AGENCY APPROVALS:

- NSF Listed
- ETL Design Certified to ANSI Z83.11 • CSA 1.8
- CE Approved • EN 203-1



HDS-47 [Rev. 1/12]

LEGEND™ Heavy-Duty Range Match Gas Fryers

Item No. _____

Project _____

Quantity _____

Gas Fryers

Dimensions in brackets are millimeters

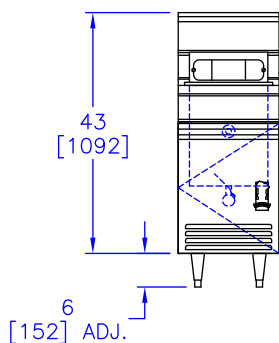

FRONT VIEW

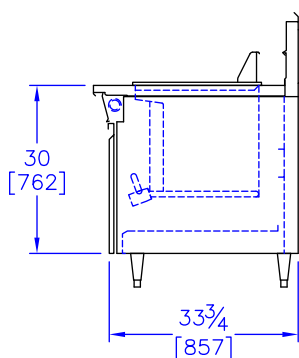

RIGHT SIDE VIEW

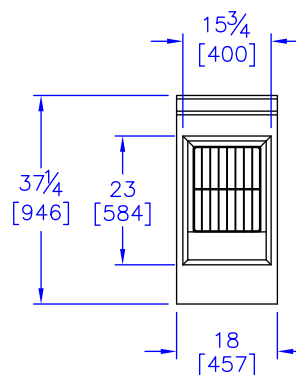

TOP VIEW

OPTIONS GUIDE:

General:

- Extra baskets, Twin: ___ ea.
- Extra baskets, Triple: ___ [set of three]
- Side Splash 8" (203mm) high [for left or right]
- Stainless steel back panel
- 18" (457mm) high-back flue riser
- Inset covers, stainless steel: ___ ea. [frypot]
- Portable filtering system [for use with RD18]
- Flanged feet with holes

Special finish: [Consult factory]

Manifolds: [Left rear with pressure regulator]:

- 1" NPT up to 500,000BTU/hr
- Manifold Cap:** left side right side
- Stainless Manifold Cover:** left side right side

International Approvals:

- CE - Conformance Européenne - EN203-1
- Includes flame failure valve option*
- Canadian Approval

INSTALLATION REQUIREMENTS & SHIPPING INFORMATION

- Fryers must be installed in accordance with local codes or in their absence with the National Fuel Gas Code: ANSI Z223.1; Natural Fuel Gas Code: CAN/CGA-B149.1 or Propane Installation Code: CAN/CGA-B149.2, as applicable. Compliance with codes is the responsibility of the Owner and Installer.
- An adequate ventilation system is required. Refer to National Fire Protection Association Standard No. 96, "Vapor Removal from Cooking Equipment."
- This appliance is intended for commercial use by professionally trained personnel. NOT intended for Residential Use.
- Specify installation elevation: _____ if above 2,000 ft(610m).
- GAS INLET SIZE (All Models):** 1-1/4 NPT front manifold with 1/2 union on each end provided for battery connection. A properly sized gas pressure regulator must be furnished by the Installer.
- The incoming gas line pressure into the regulator should be 8"-14" w.c. for natural gas, and 12"-14" w.c. for propane gas.

Minimum Clearances	Combustible Construction	Noncombustible Construction
From Back Wall	NA	6" (381mm)
Left & Right Side	6" (152mm)	0"
With 6" (152mm) legs	Suitable for installation on combustible floors	

Specify Type of Gas:		<input type="checkbox"/> Natural	<input type="checkbox"/> Propane	Shipping Weight	Shipping Class	Cube (Crated) ft ³ /m ³
Manifold Pressure:		4.0" WC	10.0" WC			
Models:	Burners	BTU/hr* (kW)	BTU/hr* (kW)			
RF40	1	110,000 (32.2)	110,000 (32.2)	251 lbs (114 kg)	85	18/5
RF240	2	220,000 (64.4)	220,000 (64.4)	423 lbs (192 kg)	85	36/1.0
RD18				238 lbs (108 kg)	85	15/4

*Total BTU Input/firing rate

RF240 Entry Clearance: 36-1/8" (918mm) uncrated.



THE MONTAGUE COMPANY
 1830 Stearman Avenue, Hayward, CA 94545
 800 345-1830 • Fax: 510 785-3342
www.montaguecompany.com

Due to continuous product improvements, specifications are subject to change without notice.



HDS-47 [Rev. 1/12]