



# VECTAIRE™ Half-Size Electric Convection Oven

Item No. \_\_\_\_\_

Project \_\_\_\_\_

Quantity \_\_\_\_\_

## EK8 Series



Model EK8A

### MODEL-DOOR SWING-PAN/RACK GUIDE:

✓	Model No.	Ovens	Door Swing	Pan Loading	Racks/Positions	Rack Spacing	
						5-racks	9-racks
	EK8(N)A	single	left	Lengthwise	5/9	3-3/8" (86mm)	1-1/2" (38mm)
	EK8(O)A	single	right	Lengthwise	5/9	3-3/8" (86mm)	1-1/2" (38mm)

18"x 13" (457 x 330mm) size pans

### EXTERIOR CONSTRUCTION FEATURES:

- Ball bearing mounted single door
- Double pane thermal viewing window
- Tubular grab-bar handle with insulated comfort grip
- Durable, adjustable door gasket
- Satin finish stainless front, sides, top and back

### CONTROL FEATURES (EACH DECK):

- Power/fan speed control (two speed fan)
- Snap-action electric thermostat with 200-500°F (93-260°C) range
- Power indicator light
- 60-minute electric countdown timer with alarm
- Moisture vent

### AGENCY APPROVALS

- NSF Listed
- UL Listed (ANSI/UL-197)

### SHORT/BID SPECIFICATION

Convection oven(s) shall be a Montague **Vectaire** half-size electric Model [Specify one]:

- EK8(N)A** a single countertop unit with left door swing  
 **EK8(O)A** a single countertop unit with right door swing

...with three tubular heating elements (per section); a stainless steel oven interior with two speed fan, nine rack positions, five bright nickel racks with rack stops and no-tip guides standard; ball bearing mounted single door with double pane viewing window; plus all the features listed and options/accessories checked:

### OVEN INTERIOR CONSTRUCTION:

- All stainless steel oven interior
- Nine-position bright nickel rack guides
- Five bright nickel pan racks, with rack-stop and no-tip guides standard
- 4" (102mm) of insulation compressed to 2" (51mm) with metal sheathing

### HEATING ELEMENTS & BLOWER SYSTEM:

- Three 2.6-kW heating elements
- Blower with 1/2 horsepower single speed motor



VCO-9 [Rev. 1/12]

Item No. \_\_\_\_\_

Project \_\_\_\_\_

Quantity \_\_\_\_\_

# VECTAIRE™ Half-Size Electric Convection Oven

**EK8**

Dimensions in brackets are millimeters

⊙ DENOTES TERMINAL BLOCK FOR FIELD SUPPLY CONNECTION

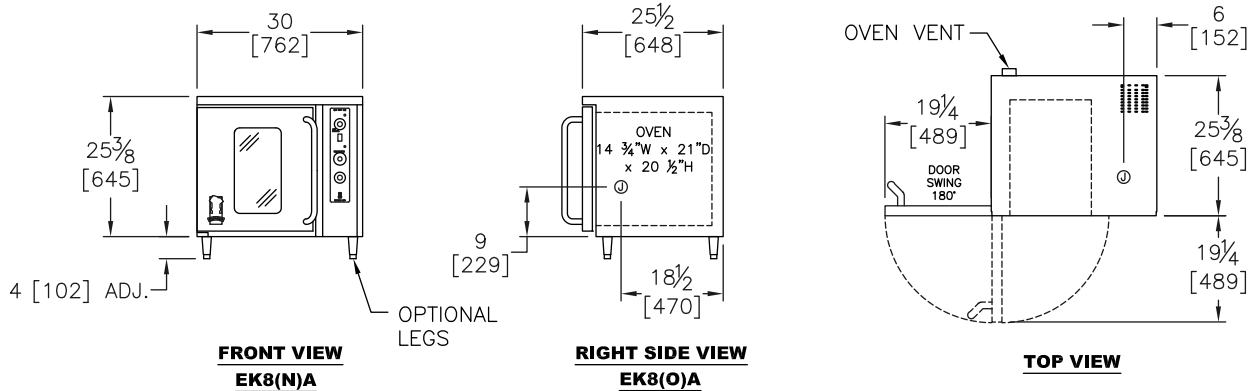

## OPTIONS GUIDE:

### Installation Alternatives:

- Set of four 4" (102mm) stainless steel legs

### Electric, Control & Motor Alternatives:

- Two speed fan motor [208/240]

### Finish:

- Stainless steel back

### Racks & Security:

- Extra Racks: \_\_\_\_\_ ea.
- Rack guide for Gastronomie Pans GN 1/1
- Solid Doors [in place of windows]
- Security Options [Consult Factory]
- 11-position rack guides
- Stainless Steel Drip Tray

## INSTALLATION REQUIREMENTS & SHIPPING INFORMATION

1. Oven must be installed in accordance with local codes or in their absence with the National Electric Code: ANSI/NFPA 70. Compliance with codes is the responsibility of the Owner and Installer.
2. An adequate ventilation system is required. Refer to National Fire Protection Association Standard No. 96, "Vapor Removal from Cooking Equipment."
3. This appliance is intended for commercial use by professionally trained personnel. NOT intended for Residential Use.

Minimum Clearances	Combustible Construction	Noncombustible Construction
From Back Wall	0"	0"
Left & Right Side*	0"	0"
*With or without 4" (102mm) legs, EK8 Models on non-combustible tables or counters only.		

### Electric Requirements\* — All Models — Per Oven/Deck

Voltage	Phase	Hz	Total kW	Nominal AMP/Line			Minimum Circuit Capacity
				L1	L2	L3	
208	1	60	7.9	38			48
240	1	60	7.9	33			48
208	3	60	7.9	26	26	24	33
240	3	60	7.9	23	23	21	33

\*Other Voltage/Hz models available. Consult factory.

### Shipping Information:

Models	Weight	Shipping Class	Cube (Crated) ft <sup>3</sup> /m <sup>3</sup>
<b>EK8 [all]</b>	229lbs (104 kg)	70	15/.4
Entry clearance 26" (660mm) uncrated			



## THE MONTAGUE COMPANY

1830 Stearman Avenue, Hayward, CA 94545  
 800 345-1830 • Fax: 510 785-3342  
 www.montaguecompany.com

Due to continuous product improvements, specifications are subject to change without notice.



VCO-9 [Rev. 1/12]