



LEGEND™ Heavy Duty Gas Deluxe Griddles

Item No. _____

Project _____

Quantity _____

DG24-SAT Series



Model DG2448-SAT shown, with optional equipment stand and 5" (127 mm) casters

MODEL GUIDE				
✓	Model No.	Overall Width	Zones	Cooking Area
	DG2424-SAT	24" (610mm)	2	24" x 24" (610 x 610mm)
	DG2436-SAT	36" (914mm)	3	36" x 24" (914 x 610mm)
	DG2448-SAT	48" (1219mm)	4	48" x 24" (1219 x 610mm)
	DG2460-SAT	60" (1524mm)	5	60" x 24" (1524 x 610mm)
	DG2472-SAT	72" (1829mm)	6	72" x 24" (1829 x 610mm)

AGENCY APPROVALS

- NSF Listed
- CSA Design Certified to ANSI Z83.11, CSA 1.8

SHORT/BID SPECIFICATION

Griddle shall be a Montague **Legend** Heavy-Duty Counter Model:

- DG24-SAT** [Specify width: 24" (610mm), 36" (914mm), 48" (1219mm), 60" (1524mm) or 72" (1829mm)]...gas-fired unit with individual 30,000 BTU/hr 'U' burners with snap-action thermostats; a 1" thick, 24" deep polished cook surface with 4" back splash and tapered side splashes; front grease trough with drop to large-capacity grease drawer(s); stainless steel front and sides with 4" (102mm) legs; plus all the features listed and options/accessories checked

GRIDDLE TOP FEATURES:

- 1" (25mm) thick precision-ground & polished steel cook top
- Full 24" (610mm) plate depth for maximum cook surface
- 4" (102mm) high backsplash and full tapered side-splashes
- 3-1/2" (89mm) wide front grease trough
- Large 4-1/2 quart grease drawer with anti-splash baffle [two on 48" (1219mm) and larger]

BURNERS & CONTROLS:

- One 30,000 BTU/hr aluminized steel 'U' burner for each 12" (305mm) of griddle width
- Individual snap-action thermostat for each heat zone
- Standing pilot for automatic ignition
- Safety pilot valve

STANDARD CONSTRUCTION FEATURES:

- Satin finish stainless steel front and sides
- Other surfaces painted black with electrolytic zinc undercoating
- 4" (102mm) stainless steel height-adjustable feet
- 6' (1829mm) 120-volt power cord with NEMA 5-15 Plug provided
- 3/4" NPT rear gas manifold connection



MISC-2 [Rev. 1/12]

Item No. _____

Project _____

Quantity _____

LEGEND™ Heavy Duty Gas Deluxe Griddles

DG24-SAT Series

Dimensions in brackets are millimeters

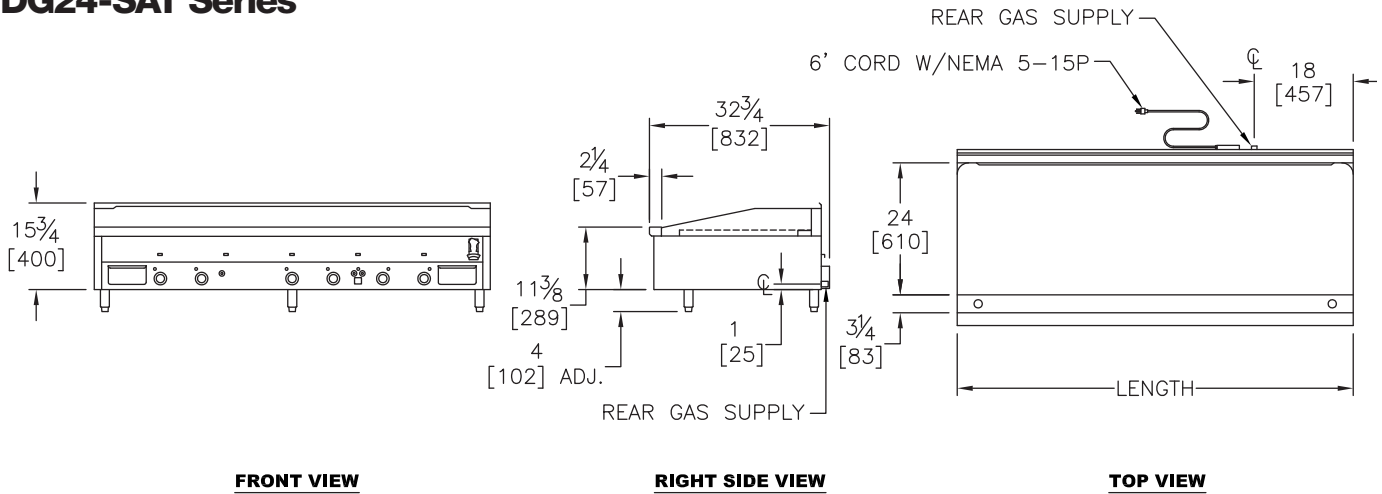

OPTIONS GUIDE:

General:

- Stainless steel back panel
- Stainless steel griddle stand with lower shelf
- Griddle stand casters — heavy-duty 5" (127mm)

Griddle Top & Controls:

- Polished chrome surface griddle plate
- Solid state thermostat controls [-SST suffix]
- Automatic pilot re-light

Burner Section Substitution:

- Substitute two 30,000 BTU/hr Open Burners for 12" (305mm) of Griddle:
2 OB (L or R) [36-72" (914-1829mm) models]
- Substitute four 30,000 BTU/hr Open Burners for 24" (610mm) of Griddle:
4 OB (L or R) [48-72" (914-1219mm) models]

International Approvals:

- Canadian Approval

INSTALLATION REQUIREMENTS & SHIPPING INFORMATION

- Griddles must be installed in accordance with local codes or in their absence with the National Fuel Gas Code: ANSI Z223.1. Compliance with codes is the responsibility of the Owner and Installer.
- An adequate ventilation system is required. Refer to National Fire Protection Association Standard No. 96, Standard for Ventilation Control and Fire Protection of Commercial Cooking Operations.
- This appliance is intended for commercial use by professionally trained personnel. NOT intended for Residential Use.
- Specify installation elevation: _____ if above 2000 feet (610m).
- GAS INLET SIZE (All Models): $3/4"$ NPT right-rear gas inlet. $3/4"$ NPT gas pressure regulator is provided and must be installed (by others) when unit is connected to gas supply.

Minimum Clearances	Combustible Construction	Noncombustible Construction
From Back Wall	3" (76mm)	0"
Left & Right Side	2" (51mm)	0"
For installation on combustible floors with 24" (610mm) high stand.		
For installation on non-combustible counter with 4" (102mm) high legs.		

Specify Type of Gas:		<input type="checkbox"/> Natural	<input type="checkbox"/> Propane	Electrical	Shipping Weight	Shipping Class	Cube (Crated) ft ³ /m ³
Manifold Pressure:		6.0" WC	10.0" WC	120V			
Models:	Burners	BTU/hr* (kW)	BTU/hr* (kW)	Amperage			
DG2424-SAT	2	60,000 (17.5)	60,000 (17.5)	0.2	290 lbs (132 kg)	85	54/1.5
DG2436-SAT	3	90,000 (26.4)	90,000 (26.4)	0.4	402 lbs (182 kg)	85	60/1.7
DG2448-SAT	4	120,000 (35.2)	120,000 (35.2)	0.5	580 lbs (263 kg)	85	64/1.7
DG2460-SAT	5	150,000 (43.9)	150,000 (43.9)	0.6	692 lbs (314 kg)	85	74/2.1
DG2472-SAT	6	180,000 (52.7)	180,000 (52.7)	0.7	804 lbs (365 kg)	85	80/2.3

*Add 10,000 BTU/hr (2.9 kWh) for each optional 25,000 BTU/hr star burner.

Entry clearance 24" (610mm) crated.

Due to continuous product improvements, specifications are subject to change without notice.



THE MONTAGUE COMPANY

1830 Stearman Avenue, Hayward, CA 94545
800 345-1830 • Fax: 510 785-3342
www.montaguecompany.com

