



LEGEND™ Heavy-Duty Gas Infrared Cheesemelters

Item No. _____

Project _____

Quantity _____

CM Series



Model CM36 Shown

MODEL GUIDE			
Model No.	Mounting	Shelf Width	Power BTU/hr (kW)
CM24*	24" (610mm)	21-1/2" (546mm)	20,000 (5.8)
CM36*	36" (914mm)	33-1/2" (851mm)	32,000 (9.4)
CM48*	48" (1219mm)	45-1/2" (1156mm)	40,000 (11.7)
CM60*	60" (1524mm)	57-1/2" (1461mm)	52,000 (15.2)
CM72*	72" (1829mm)	69-1/2" (1765mm)	64,000 (18.8)

*Also CM__-HB Range-Mounted Models

STANDARD CONSTRUCTION FEATURES:

- Satin finish stainless steel throughout
- 1" (25mm) high rear flue riser
- 3/4" NPT gas connection [location varies by model]

AGENCY APPROVALS

- NSF Listed
- CSA Design Certified to ANSI Z83.11 • CSA 1.8

SHORT/BID SPECIFICATION

Cheesemelter shall be a Montague **Legend** Heavy-Duty Model:

- CM24** 24" wide (610mm)
- CM36** 36" wide (914mm)
- CM48** 48" wide (1219mm)
- CM60** 60" wide (1524mm)
- CM72** 72" wide (1829mm)

[add **-HB** for High Back mounting on 136-, V136- or 36- Series Legend Range]

...a gas-fired infrared heated overfired unit with nickel-plated steel plate shelf with four-position side support racks; plus all the features listed and options/accessories checked:

RAPID-START INFRARED BURNER FEATURES:

- 20,000 and/or 32,000 BTU/hr ceramic tile burners [depending on model]
- Top-mounted ceramic burner ensures uniform infrared heating
- Full flow ON/OFF operation
- Standing pilot for automatic ignition

PLATE SHELF FEATURES:

- One piece nickel-plated plate shelf: 13-1/8" deep (333mm) x [See width chart]
- Four-position nickel-plated rack guides to adjust distance to burners
- Open design for easy a-la-carte use and cleaning

MOUNTING ALTERNATIVES:

- **CM__-HB Models** are High Back mounted on a 136-, V136- or 36-Series Legend Range
- **CM__ Models** are designed for (non-combustible) countertop mounting [See OPTIONS for 4" (102mm) legs or wall-mounting support brackets]



HDB-20 [Rev. 1/12]

LEGEND™ Heavy-Duty Gas Infrared Cheesemelter

Item No. _____

Project _____

Quantity _____

CM Series

Dimensions in brackets are millimeters

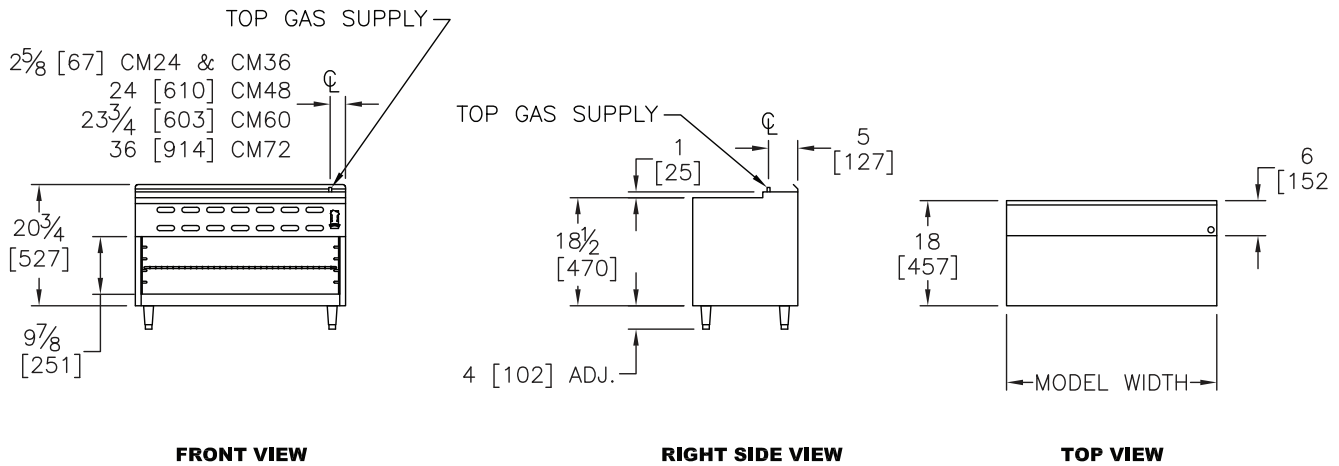

OPTIONS GUIDE:

Finish:

- Stainless steel back panel

Mounting:

- Wall mounting brackets
 4" (102mm) legs — satin finish stainless steel
 Note: Legs not can be added in the field.

General:

- Pass-thru Cheesemelter [Consult Factory]
 Interconnect to range available with high back option

INSTALLATION REQUIREMENTS & SHIPPING INFORMATION

- Broilers must be installed in accordance with local codes or in their absence with the National Fuel Gas Code: ANSI Z223.1; Natural Fuel Gas Code: CAN/CGA-B149.1 or Propane Installation Code: CAN/CGA-B149.2, as applicable. Compliance with codes is the responsibility of the Owner and Installer.
- An adequate ventilation system is required. Refer to National Fire Protection Association Standard No. 96, "Standard for Ventilation and Fire Protection of Commercial Cooking Operations."
- This appliance is intended for commercial use by professionally trained personnel. NOT intended for Residential Use.
- Specify installation elevation: _____ if above 2000 feet (610m).
- GAS INLET SIZE/LOCATION (All Models): 3/4" NPT:
 - CM24 & CM36: 2-5/8" (67mm) from right side
 - CM48 & CM72: centered
 - CM60: 23-3/4" (603mm) from right side
- A 3/4" NPT gas pressure regulator is provided and must be installed (by others) when unit is connected to gas supply.
- The incoming gas line pressure into the regulator should be 8"-14" w.c. for natural gas, and 12"-14" w.c. for propane gas.

Minimum Clearances	Noncombustible Construction
From Back Wall	0"
Left & Right Side	0"
For use in non-combustible locations ONLY	

Specify Type of Gas:		<input type="checkbox"/> Natural	<input type="checkbox"/> Propane
Manifold Pressure:		6.0" WC	10.0" WC
Models:	Burners	BTU/hr* (kW)	BTU/hr* (kW)
CM24 (-HB)	1	20,000 (5.8)	20,000 (5.8)
CM36 (-HB)	1	32,000 (9.4)	32,000 (9.4)
CM48 (-HB)	2	40,000 (11.7)	40,000 (11.7)
CM60 (-HB)	2	52,000 (15.2)	52,000 (15.2)
CM72 (-HB)	2	64,000 (18.8)	64,000 (18.8)

*Total - 20,000 and/or 32,000 burners

Unit Width	Shipping Weight lbs/(kg)		Shipping Class	Cube (Crated) ft ³ /m ³	
	CM-Models Counter/Wall	CM-HB Models with High Backs		CM	CM-HB
24" (610 mm)	130 (59)	216 (98)	85	13/.4	29/.8
36" (914 mm)	164 (74)	232 (105)	85	13/.4	32/.9
48" (1219 mm)	256 (116)	309 (140)	85	17/.5	38/1.1
60" (1524 mm)	300 (136)	387 (175)	85	20/.6	47/1.3
72" (1829 mm)	347 (157)	464 (210)	85	25/.7	56/1.6



THE MONTAGUE COMPANY

1830 Stearman Avenue, Hayward, CA 94545

800 345-1830 • Fax: 510 785-3342

www.montaguecompany.com

Due to continuous product improvements, specifications are subject to change without notice.



HDB-20 [Rev. 1/12]