



# LEGEND™ Heavy-Duty Gas 36" Counter-Top Open Top/Hot Top Models

Item No. \_\_\_\_\_

Project \_\_\_\_\_

Quantity \_\_\_\_\_



Model C36-5 shown

## SHORT/BID SPECIFICATION

Counter-Top unit shall be a Montague *Legend* Heavy Duty Open-Burner Model: C36\_\_ [Specify suffix]:

- 5** for three 12" x 31" (305 x 787mm) heavy cast iron, precision ground open top grates, each with two 30,000 BTU/hr lift off star burners; or
- 2E** or **-4E** for two 12" x 31" (305 x 787mm) heavy cast iron, precision ground open top grates, each with two 30,000 BTU/hr lift off star burners, plus one 18" wide x 31" (457 x 787mm) deep Hot Top, with cast iron precision ground plate and 15,000 BTU/hr burner; or
- 559** for three 12" x 15-1/2" (305 x 394mm) heavy cast iron, precision ground open top grates one 30,000 BTU/hr lift off star burner, plus three 12" wide x 15-1/2" (305 x 394mm) deep Hot Tops positioned behind the open burners, with cast iron precision ground plate and individual EVEN HEAT 20,000 BTU/hr burners; or
- 3E** or **-10E** for one 12" x 31" (305 x 787mm) heavy cast iron, precision ground open top grates, with two 30,000 BTU/hr lift off star burners, plus two 12" wide x 31" (305 x 787mm) deep Hot Tops positioned right, with cast iron precision ground plate and individual EVEN HEAT 20,000 BTU/hr burners; or
- 5A** for two 18" x 31" (457 x 787mm) heavy cast iron, precision ground open top grates, each with two 30,000 BTU/hr lift off star burners; or
- 11** or **-14** for one 18" x 31" (457 x 787mm) heavy cast iron, precision ground open top grates, with two 30,000 BTU/hr star burners, plus one 18" (457mm) wide French-Top with individual 35,000 BTU/hr burner with ring and cover in front of cast iron plate; or
- 11E** or **-14E** for one 18" x 31" (457 x 787mm) heavy cast iron, precision ground open top grate, with two 30,000 BTU/hr lift off star burners, plus one 18" wide x 31" (457 x 787mm) deep Hot Top positioned right, with cast iron precision ground plate and two individual EVEN HEAT 20,000 BTU/hr burners;

...mounted on a 36" (914mm) wide heavy duty base with stainless steel front, 4" (102mm) high flue riser, 3" (76mm) deep front rail and 4" (102mm) legs standard; plus all the features listed and options/accessories checked:

MODEL GUIDE				
✓	Model No.	Top Sections/Configuration		
		Overall Width	Open Tops	Hot Tops
	C36-5	36" (914mm)	Three 12"	
	C36-2E & -4E	36" (914mm)	Two 12"	One 12" EVEN HEAT
	C36-559/559S*	36" (914mm)	Three 12" in front	Three 12" in back
	C36-3E & -10E	36" (914mm)	One 12"	Two 12" (305mm) EVEN HEAT
	C36-5A	36" (914mm)	Two 18"	
	C36-11 & -14	36" (914mm)	One 18"	One 18" (457mm) French-Top
	C36-11E & -14E	36" (914mm)	One 18"	One 18" (457mm) EVEN HEAT

\*Model C36-559S is step-up model

## OPEN BURNER FEATURES:

12" or 18" wide x 31" deep (305 or 457 x 787mm) open burner top(s) with:

- Heavily ribbed cast iron, surface-ground top grate
- Two large diameter 30,000 BTU/hr lift off star burners with raised ports
- Individual burner controls
- Automatic, standing pilots
- Drip pan positioned under open burners

## EVEN HEAT HOT TOP FEATURES:

12" or 18" wide x 31" deep (305 or 457 x 787mm) Even Heat hot top(s) with:

- Heavy cast iron precision ground plate
- EVEN HEAT 20,000 BTU/hr burner
- Heat transfer studs cast in plate bottoms
- 2" (51mm) side and front flanges isolate heat under plate

## FRENCH-TOP FEATURES:

18" wide x 31" deep (457 x 787mm) French-Top with:

- Heavy cast iron precision ground plate with
- Front-positioned removable ring & cover
- Front fired, banjo-type 35,000 BTU/hr burner
- Heat transfer studs cast in plate bottom

## STANDARD BASE CONSTRUCTION:

- Satin finish stainless steel front, with 3" (76mm) deep front rail
- Stainless steel exterior bottom
- Stainless steel 4" (102mm) rear flue riser
- 4" (102mm) adjustable nickel finish legs
- 1-1/4" front gas manifold with 1/2 union on each end

## AGENCY APPROVALS

- NSF Listed
- ETL Design Certified to ANSI Z83.11 • CSA 1.8
- CE Approved • EN 203-1



HDCS-13 [Rev. 1/12]

# LEGEND™ Heavy-Duty Gas 36" (914mm) Counter-Top Open Top/Hot Top Models

Item No. \_\_\_\_\_

Project \_\_\_\_\_

Quantity \_\_\_\_\_

Dimensions in brackets are millimeters

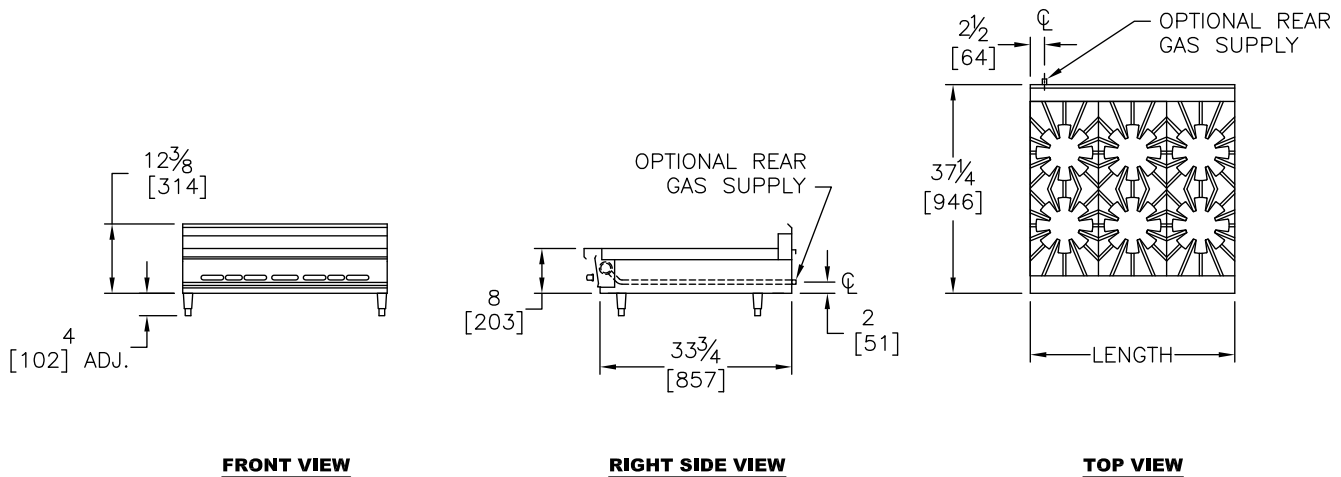

## OPTIONS GUIDE:

### General:

- 18" (457mm) high riser
- 6" (152mm) wide stainless steel plate shelf
- Equipment Stand [Consult Factory]

### Flex Connector Kit [1" NPT]:

- 3' (914mm)  4' (1219mm)

### Security Options/Prison Package

[Consult Factory]

### Manifolds:

[Specify left or right rear with pressure regulator]:

- 1" NPT up to 400,000 BTU/hr

### Manifold Cap:

- left side  right side

### Stainless Manifold Cover:

- left side  right side

### Open Burner Top Sections:

- 12" Cast Iron Ribbon Grate (requires thermostat) [In place of star grate section]
- 304 stainless steel burner box assembly
- 20,000 BTU/hr Star Burner

**Controls:** \*Options include 304 stainless steel burner box assembly and lift out 304 stainless steel drip pans. [see Heavy Duty option page HDS-44]

- \*Electronic rangetop pilot ignition
- \*Flame failure rangetop safety valves
- \*Electronic rangetop pilot ignition & flame failure rangetop safety valves

### Finish:

- Stainless steel back panel
- Stainless steel side panels:
  - left side  right side

### Special Finish

[Consult Factory]

### International Approvals:

- CE - Conformance Européenne - EN203-1  
*Includes flame failure valve option*
- AGA - Australian Gas Association - AS 4563  
*Includes flame failure valve option*
- Canadian Approval

## INSTALLATION REQUIREMENTS & SHIPPING INFORMATION

- Counter-Top Unit must be installed in accordance with local codes or in their absence with the National Fuel Gas Code: ANSI Z223.1; Natural Fuel Gas Code: CAN/CGA-B149.1 or Propane Installation Code: CAN/CGA-B149.2, as applicable. Compliance with codes is the responsibility of the Owner and Installer.
- An adequate ventilation system is required. Refer to National Fire Protection Association Standard No. 96, "Vapor Removal from Cooking Equipment."
- This appliance is intended for commercial use by professionally trained personnel. NOT intended for Residential Use.
- Specify installation elevation: \_\_\_\_\_ if above 2000 feet (610m).
- GAS INLET SIZE (All Models): 1-1/4" (32mm) front manifold with 1/2" union on each end provided for battery connection. A properly sized gas pressure regulator must be furnished by the Installer.
- The incoming gas line pressure into the regulator should be 8"-14" w.c. for natural gas, and 12"-14" w.c. for propane gas.

Minimum Clearances	Combustible Construction	Noncombustible Construction
From Back Wall	2" (51mm)	0"
Left & Right Side	6" (152mm)*	0"
With or without 4" (102mm) legs	Suitable for installation on non-combustible counters ONLY	
<b>*15" side clearance with open tops</b>		

Specify Type of Gas:		<input type="checkbox"/> Natural	<input type="checkbox"/> Propane	Shipping Weight	Shipping Class	Cube (Crated) ft <sup>3</sup> /m <sup>3</sup>
Manifold Pressure:		6.0" WC	10.0" WC			
Models:	Burners	BTU/hr (kW)	BTU/hr (kW)			
C36-5	6	180,000 (52.7)	180,000 (52.7)	300 lbs (136 kg)	85	14/.4
C36-2E & -4E	5	140,000 (41)	140,000 (41)	315 lbs (143 kg)	85	14/.4
C36-559/559S	6	135,000 (39.6)	135,000 (39.6)	325 lbs (147 kg)	85	14/.4
C36-3E & -10E	4	100,000 (29.3)	100,000 (29.3)	380 lbs (172 kg)	85	14/.4
C36-5A	4	120,000 (35.2)	120,000 (35.2)	272 lbs (123 kg)	85	14/.4
C36-11 & -14	3	95,000 (27.8)	95,000 (27.8)	306 lbs (139 kg)	85	14/.4

Due to continuous product improvements, specifications are subject to change without notice.



## THE MONTAGUE COMPANY

1830 Stearman Avenue, Hayward, CA 94545  
 800 345-1830 • Fax: 510 785-3342  
 www.montaguecompany.com

