



# LEGEND™ Heavy-Duty Gas 36" (914mm) Counter-Top Griddle Plus Models

Item No. \_\_\_\_\_

Project \_\_\_\_\_

Quantity \_\_\_\_\_



Model C36-12E shown

## SHORT/BID SPECIFICATION

Counter-Top unit shall be a Montague **Legend Heavy Duty Griddle Plus**  
Model: **C36\_\_** plus suffix:

- 0E** for 24" (610mm) wide griddle top with 3/4" (19mm) thick precision ground cook surface, plus a 12" wide x 31" (305 x 787mm) deep Hot Top, with cast iron precision ground plate and EVEN HEAT 20,000 BTU/hr burner;
- 1E** for 12" (305mm) wide griddle top with 3/4" (19mm) thick precision ground cook surface, plus two 12" wide x 31" (305 x 787mm) deep Hot Tops, with cast iron precision ground plates and EVEN HEAT 20,000 BTU/hr burners;
- 6** for 12" (305mm) wide griddle top with 3/4" (19mm) thick precision ground cook surface, plus two 12" (305mm) heavy-duty cast iron, precision ground open top grates, over four 30,000 BTU/hr lift off star burners;
- 7** for 24" (610mm) wide griddle top with 3/4" (19mm) thick precision ground cook surface, plus one 12" x 31" (305 x 787mm) heavy cast iron, precision ground open top grate with two 30,000 BTU/hr lift off star burners;
- 12** for 18" (457mm) wide griddle top with 3/4" (19mm) thick precision ground cook surface, plus one 18" wide French-Top with 35,000 BTU/hr burner with ring and cover in front of cast iron plate;
- 12E** for 18" (457mm) wide griddle top with 3/4" (19mm) thick precision ground cook surface, plus one 18" wide precision-ground EVEN HEAT hot top with (2) 20,000 BTU/hr burner,
- 13** for 18" (457mm) wide griddle top with 3/4" (19mm) thick precision ground cook surface, plus one 18" wide heavy-duty cast iron, precision ground open top grate, with two 30,000 BTU/hr lift off star burners;

...mounted on a 36" (914mm) wide heavy-duty base with stainless steel front, 4" (102mm) high flue riser, 3" (76mm) deep front rail and 4" (102mm) legs standard; plus all the features listed and options/accessories checked:

MODEL GUIDE*		
Model No.	Griddle Plate Size*	Additional Open Burners / Hot Tops
C36-0E	24" (610mm)	One 12" Hot Top (305mm)
C36-1E	12" (305mm)	Two 12" Hot Tops (305mm)
C36-6	12" (305mm)	Four 12" Open Tops (305mm)
C36-7	24" (610mm)	Two 12" Open Tops (305mm)
C36-12	18" (457mm)	One 18" Ring/One French Top (457mm)
C36-12E	18" (457mm)	One 18" Hot Top (457mm)
C36-13	18" (457mm)	Two 18" Open Tops (457mm)

\*Griddle sections are positioned left.

## STANDARD GRIDDLE FEATURES:

24" (610mm), 18" (457mm) or 12" (305mm) wide x 28" (711mm) deep fry top, *positioned left*, with:

- 3/4" (19mm) thick precision-ground steel cook surface
- 4" (102mm) high backsplash and tapered side-splashes
- 2-5/8" (67mm) wide front grease trough pitched to the grease drop
- Built-in one gallon capacity grease drawer
- 15,000 BTU/hr gas burner(s) with standing pilots & gas control valves
- Adjusting bolts for changing griddle forward pitch

## OPEN BURNER FEATURES [-6, -7 & -13 MODELS]:

12" or 18" wide x 31" deep (305 or 457 x 787mm) open burner top(s), *positioned right*, with:

- Heavy-duty ribbed cast iron, surface-ground top grate
- Two large diameter 30,000 BTU/hr lift off star burners with raised ports
- Individual gas control valves
- Automatic, standing pilots
- Drip pan positioned under open burners

## FRENCH-TOP FEATURES [-12 MODEL]:

18" wide x 31" deep (457 x 787mm) French-Top *positioned right*, with:

- Heavy-duty cast iron precision ground plate
- Front-positioned removable ring & cover
- Front fired, banjo-type 35,000 BTU/hr burner
- Heat transfer studs cast in plate bottom

## EVEN HEAT HOT TOP FEATURES [-0E, 1E & 12E MODELS]:

12" or 18" wide x 31" (305 or 457 x 787mm) deep Even Heat hot top(s) *positioned right*, with:

- Heavy cast iron precision ground plate
- EVEN HEAT 20,000 BTU/hr burner
- Heat transfer studs cast in plate bottoms
- 2" (51mm) side and front flanges isolate heat under plate

## STANDARD BASE CONSTRUCTION:

- Satin finish stainless steel front, with 3" (76mm) deep front rail
- Stainless steel exterior bottom
- Stainless steel 4" (102mm) rear flue riser
- 4" (102mm) adjustable nickel finish legs
- 1-1/4" front gas manifold with 1/2 union on each end

## AGENCY APPROVALS

- NSF Listed
- ETL Design Certified to ANSI Z83.11 • CSA 1.8
- CE Approved • EN 203-1



HDCS-11 [Rev. 1/12]

# LEGEND™ Heavy-Duty Gas 36" (914mm) Counter-Top Griddle Plus Models

Item No. \_\_\_\_\_

Project \_\_\_\_\_

Quantity \_\_\_\_\_

Dimensions in brackets are millimeters

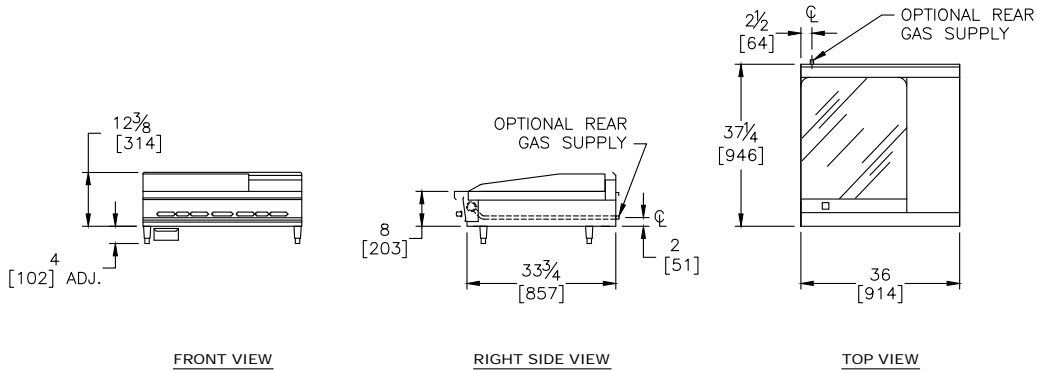

## OPTIONS GUIDE:

### General:

- 8" plate shelf
- 18" (457mm) high riser
- 6" (152mm) wide stainless steel plate shelf
- Equipment Stand [Consult Factory]

### Flex Connector Kit [1"] NPT:

- 3' (914mm)  4' (1219mm)

### Security Options/Prison Package

[Consult Factory]

### Griddle/Fry Top:

- 450° Thermostatic Control [one for 24" (610mm) top]
- 550° Thermostatic Control [one for 24" (610mm) top]
- 1" (25mm) thick griddle plate
- 1" (25mm) thick grooved griddle plate
- 34" (864mm) deep plate [Add Suffix -40]

- Reversed Frytop [Add Suffix -R]
- 1" Chrome Griddle (thermostats required)

### Manifolds:

[Specify left or right rear with pressure regulator]:

- 1" NPT up to 400,000 BTU/hr

### Manifold Cap:

- left side  right side

### Stainless Manifold Cover:

- left side  right side

### Open Burner Top Sections:

- 30,000 BTU lift off burner with a rear solid hot top 15,000 BTU/hr each [add -59 to suffix]
- Cast Iron Ribbon Grate
- 304 stainless steel burner box assembly
- 20,000 BTU burners [reqd w/ Ribbon Grate]

**Controls:** \*Options include 304 stainless steel burner box assembly and lift out 304 stainless steel

drip pans (Open tops only)[see Heavy Duty option page HDS-44]

- \*Electronic rangetop pilot ignition
- \*Flame failure rangetop safety valves
- \*Electronic rangetop pilot ignition & flame failure rangetop safety valves

### Finish:

- Stainless steel back panel
- Stainless steel side panels:
  - left side  right side

### Special Finish

[Consult Factory]

### International Approvals:

- CE - Conformance Européenne - EN203-1  
*Includes flame failure valve option*
- AGA - Australian Gas Association - AS 4563  
*Includes flame failure valve option*
- Canadian Approval

## INSTALLATION REQUIREMENTS & SHIPPING INFORMATION

- Counter-Top Unit must be installed in accordance with local codes or in their absence with the National Fuel Gas Code: ANSI Z223.1; Natural Fuel Gas Code: CAN/CGA-B149.1 or Propane Installation Code: CAN/CGA-B149.2, as applicable. Compliance with codes is the responsibility of the Owner and Installer.
- An adequate ventilation system is required. Refer to National Fire Protection Association Standard No. 96, "Vapor Removal from Cooking Equipment."
- This appliance is intended for commercial use by professionally trained personnel. NOT intended for Residential Use.
- Specify installation elevation: \_\_\_\_\_ if above 2,000 ft (610m).
- GAS INLET SIZE (All Models):** 1-1/4" (32mm) front manifold with 1/2" union on each end provided for battery connection. A properly sized gas pressure regulator must be furnished by the Installer.
- The incoming gas line pressure into the regulator should be 8"-14" w.c. for natural gas, and 12"-14" w.c. for propane gas.

Minimum Clearances	Combustible Construction	Noncombustible Construction
From Back Wall	2" (51mm)	0"
Left & Right Side	6" (152mm)*	0"
With or without 4" (102mm) legs	Suitable for installation on non-combustible counters ONLY	
<b>*15" clearance with open burners.</b>		

Models:	Burners	Specify Type of Gas:		Shipping Weight	Shipping Class	Cube (Crated) ft <sup>3</sup> /m <sup>3</sup>
		<input type="checkbox"/> Natural	<input type="checkbox"/> Propane			
Manifold Pressure:		6.0" WC				
		10.0" WC				
		BTU/hr (kW)	BTU/hr (kW)			
<b>C36-0E</b>	4	65,000 (19)	65,000 (19)	380 lbs (172 kg)	85	14/.4
<b>C36-1E</b>	3	55,000 (16.1)	55,000 (16.1)	350 lbs (159 kg)	85	14/.4
<b>C36-6</b>	5	135,000 (39.6)	135,000 (39.6)	330 lbs (150 kg)	85	14/.4
<b>C36-7</b>	5	105,000 (30.8)	105,000 (30.8)	370 lbs (168 kg)	85	14/.4
<b>C36-12</b>	3	65,000 (19)	65,000 (19)	478 lbs (217 kg)	85	14/.4
<b>C36-12E</b>	4	70,000 (20.5)	70,000 (20.5)	478 lbs (217 kg)	85	14/.4
<b>C36-13</b>	4	90,000 (26.4)	90,000 (26.4)	512 lbs (232 kg)	85	14/.4

Due to continuous product improvements, specifications are subject to change without notice.



## THE MONTAGUE COMPANY

1830 Stearman Avenue, Hayward, CA 94545  
800 345-1830 • Fax: 510 785-3342  
www.montaguecompany.com

