



LEGEND™ Heavy-Duty Gas Steakhouse Infrared Broiler With Top Sear Plate

Item No. _____

Project _____

Quantity _____

C36SHB or C45SHB Model



Model C45SHB shown
with optional stainless steel sides and casters

SHORT/BID SPECIFICATION

Broiler shall be a Montague **Legend** Heavy-Duty, **Steakhouse** Broiler with Top Sear Plate [Specify Model]

- C36SHB 36" (914mm) Wide
- C45SHB 45" (1143mm) Wide

...a gas-fired, infrared heated unit with 42,000 BTU/hr cast iron burners with individual controls, heating ceramic radiants mounted below a 1/2" (13mm) polished steel searing plate with 4" (102mm) rear and side splash and above; a counter-balanced, height-adjustable, chrome-plated steel cooking grid that is drawer-mounted for easy pull-out access, with a full width grease deflector and large capacity front-mounted grease container; enclosed in an insulated cabinet with stainless steel front and mounted on 25" (635mm) high stainless steel modular stand with bottom shelf; plus all the features listed and options/accessories checked:

TOP SEAR-PLATE FEATURES:

- 1/2" (13mm) thick polished steel searing plate
- 4" (102mm) high sides and rear splash
- 2-7/8" (73mm) wide left-side grease trough
- Left-front mounted removable grease container, 4-3/4 quart capacity

BURNER/RADIANT SYSTEM FEATURES:

- 42,000 BTU/hr cast iron burners
- Ceramic radiants for uniform infrared heating
- Individual burner controls
- Standing pilot for automatic ignition

MODEL GUIDE

✓	Model No.	Overall Width	Grids	Cooking Area	
				Broiler	Griddle
	C36SHB	36" (914mm)	2	27" x 27" (686 x 686mm)	33" x 28" (838 x 711mm)
	C45SHB	45" (1143mm)	3	35" x 27" (889 x 686mm)	42" x 28" (1067 x 711mm)

ROLL-OUT GRID FEATURES:

- Chrome plated steel grid sections: two on C36 & three on C45
- Counter-balanced grid assembly for easy height adjustment
- Infinite grid height adjustment from 2" to 5" (51 to 127mm)
- Positive locking lift handle with cool ball-style grip
- Quiet, ball bearing mounted roll-out grid assembly
- Shielded horizontal grab-bar handle

STANDARD CONSTRUCTION FEATURES:

- Satin finish stainless steel front
- Broiler interior high-temp aluminized finish
- Other surfaces painted black with electrolytic zinc undercoating
- Full width grease deflector under rollout grid
- Extra-large capacity removable grease drawer [for broiler]
- 3/4" NPT rear gas manifold connection
- Stainless steel stand with 4" (102mm) base and 21" (533mm) tubular legs
- Height-adjustable bullet feet
- Stainless steel bottom shelf

AGENCY APPROVALS

- NSF Listed
- CSA Design Certified to ANSI Z83.11 • CSA 1.8
- Australian Gas Association Certification Number 7466
- CE Approved EN 203-1



HDB-12 [Rev. 1/12]

LEGEND™ Heavy-Duty Gas Steakhouse Infrared Broiler with Top Sear Plate

Item No. _____

Project _____

Quantity _____

C36SHB or C45SHB Model

Dimensions in brackets are millimeters

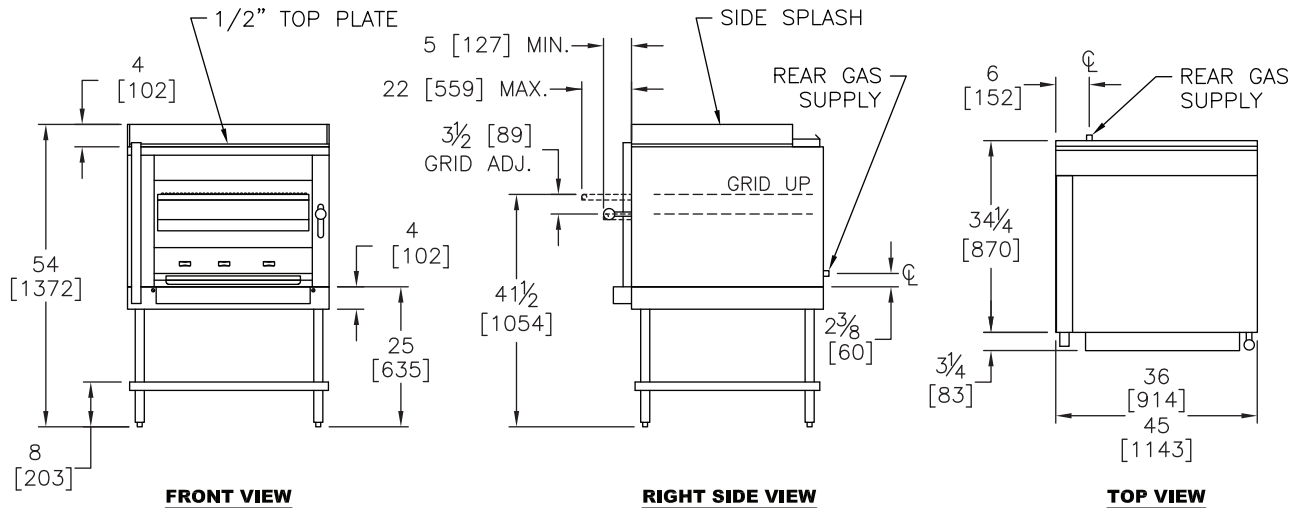

OPTIONS GUIDE:

Finish:

- Stainless steel full left side panel
- Stainless steel full right side panel
- Stainless steel back panel

General:

- Casters — set of four 5" (127mm) casters
- Flex Connector Kit [3/4"] or [1"] NPT:
 - 3' (914mm) long
 - 4' (1219mm) long

Searing Plate:

- Side Mounted grease containers holds 2 quarts

International Approvals:

- CE-Conformite Europeene
Includes Flame Failure Valve Option
- AGA-Australian Gas Association
Includes Flame Failure Valve Option
- Canadian Approval

INSTALLATION REQUIREMENTS & SHIPPING INFORMATION

- Broilers must be installed in accordance with local codes or in their absence with the National Fuel Gas Code: ANSI Z223.1; Natural Fuel Gas Code: CAN/CGA-B149.1 or Propane Installation Code: CAN/CGA-B149.2, as applicable. Compliance with codes is the responsibility of the Owner and Installer.
- An adequate ventilation system is required. Refer to National Fire Protection Association Standard No. 96, "Standard for Ventilation and Fire Protection of Commercial Cooking Operations."
- This appliance is intended for commercial use by professionally trained personnel. NOT intended for Residential Use.
- Specify installation elevation: _____ if above 2000 feet (610m).
- GAS INLET SIZE (All Models): 3/4" NPT left-rear inlet. A 3/4" NPT gas pressure regulator is provided and must be installed (by others) when unit is connected to gas supply.
- The incoming gas line pressure into the regulator should be 8"-14" w.c. for natural gas, and 12"-14" w.c. for propane gas.

Minimum Clearances	Combustible Construction	Noncombustible Construction
From Back Wall	6" (152mm)	0"
Left & Right Side	6" (152mm)	0"
With 21" (533mm) legs, suitable for use on combustible floor.		

Specify Type of Gas:		<input type="checkbox"/> Natural	<input type="checkbox"/> Propane	Shipping Weight	Shipping Class	Cube (Crated) ft ³ /m ³
Manifold Pressure:		6.0" WC	10.0" WC			
Models:	Burners	BTU/hr (kW)	BTU/hr (kW)			
C36SHB	2	84,000 (24.6)	84,000 (24.6)	483 lbs (219 kg)	85	35/1
C45SHB	3	126,000 (36.9)	126,000 (36.9)	638 lbs (289 kg)	85	47/1.3
Uncrated entry clearance: 33-1/2" (851mm)						

*Total, all burners



THE MONTAGUE COMPANY

1830 Stearman Avenue, Hayward, CA 94545

800 345-1830 • Fax: 510 785-3342

www.montaguecompany.com

Due to continuous product improvements, specifications are subject to change without notice.



HDB-12 [Rev. 1/12]