



# LEGEND™ Heavy-Duty Gas Counter-Top Planchas, Plancha Plus & Add-A-Units

Item No. \_\_\_\_\_

Project \_\_\_\_\_

Quantity \_\_\_\_\_

Photo Not Available

## SHORT/BID SPECIFICATION

Plancha shall be a Montague **Legend** Heavy Duty Counter-Top Model: C [Specify width: **18, 24 or 36"**] plus suffix:

- 8PL** for Spanish-style plancha (only) with raised 3/4" (19mm) thick precision ground cook surface, full perimeter grease trough and (3) 15,000 BTU/hr burner(s);
- 7PL** for 19" x 25" (483 x 635mm) Spanish-style plancha with raised 3/4" (19mm) thick precision ground cook surface, full perimeter grease trough and two 15,000 BTU/hr burners, plus one 12" (305mm) heavy-duty cast iron, precision ground open top grate, with two 30,000 BTU/hr star burners;
- 12PL** for 14" x 25" (356 x 635mm) Spanish-style plancha with raised 3/4" (19mm) thick precision ground cook surface, full perimeter grease trough and one 15,000 BTU/hr burner, plus one 35,000 BTU/hr, 18" (457mm) wide French Top with ring and cover in front of cast iron plate;
- 12EPL** for 14" x 25" (356 x 635mm) Spanish-style plancha with raised 3/4" (19mm) thick precision ground cook surface, full perimeter grease trough and one 15,000 BTU/hr burner, plus one 40,000 BTU/hr, 18" (457mm) wide Even Heat hot top;
- 13PL** for 14" x 25" (356 x 635mm) Spanish-style plancha with raised 3/4" (19mm) thick precision ground cook surface, full perimeter grease trough and one 15,000 BTU/hr burner, plus one 18" (457mm) heavy-duty cast iron, precision ground open top grate, with two 30,000 BTU/hr star burners;

...mounted on a heavy-duty base with stainless steel front, sides and bottom exterior, 4" (102mm) high flue riser and 3" (76mm) deep front rail standard; plus all the features listed and options/accessories checked:

## PLANCHA (SPANISH-STYLE GRIDDLE) FEATURES:

- 3/4" (19mm) thick precision-ground steel raised cook surface
- Full perimeter grease trough or gutter, with drain to:
- Two-quart hanging grease container
- 15,000 BTU/hr gas burners with standing pilots
- Individual gas control valves for zoned heating

## MODEL GUIDE

✓	Model No.	Overall Width	Plancha Plate Size	Additional burners/Tops
	C18-8PL	18" (457mm)	14" x 25" (356 x 635mm)	None
	C24-8PL	24" (610mm)	19" x 25" (483 x 635mm)	None
	C36-8PL	36" (914mm)	31" x 25" (787 x 635mm)	None
	C36-7PL	36" (914mm)	19" x 25" (483 x 635mm)	Two 12" (305mm) burners
	C36-12PL	36" (914mm)	14" x 25" (356 x 635mm)	One ring/cover top
	C36-12EPL	36" (914mm)	14" x 25" (356 x 635mm)	One 18" (457mm) hot top
	C36-13PL	36" (914mm)	14" x 25" (356 x 635mm)	Two 18" (457mm) burners

## PLUS ON -7PL & -13PL MODELS:

**12" wide x 31" (305 x 787mm) [-7PL] or 18" x 31" (457 x 787mm) deep [-13PL] open burner top, positioned right, with**

- Heavy-duty ribbed cast iron, surface-ground top grate
- Large diameter 30,000 BTU/hr lift off star burners with raised ports
- Automatic, standing pilots
- Drip pan positioned under burners

## PLUS ON -12PL MODELS:

**One 18" wide x 31" (457 x 787mm) deep French-Top positioned right, with:**

- Heavy-duty cast iron precision ground plate
- Front-positioned removable ring & cover
- Two banjo-type 35,000 BTU/hr burners
- Heat transfer studs cast in plate bottom
- Insulating partition between section
- Sloped, brick-lined flues for better heat transfer

## PLUS ON -12EPL MODELS:

**One 18" wide x 31" (457 x 787mm) deep Even Heat hot top positioned right, with:**

- Heavy-duty cast iron precision ground plate
- Two Even Heat 20,000 BTU/hr burners
- Heat transfer studs cast in plate bottom
- 2" (51mm) side and front flanges isolate heat under plate
- Insulating partition between top sections

## STANDARD BASE CONSTRUCTION:

- Satin finish stainless steel front, sides, with 3" (76mm) deep front rail
- Stainless steel exterior bottom
- Stainless steel 4" (102mm) rear flue riser
- 4" (102mm) adjustable nickel finish legs
- 1-1/4" front gas manifold with 1/2 union on each end

## AGENCY APPROVALS

- NSF Listed
- ETL Design Certified to ANSI Z83.11 • CSA 1.8
- CE Approved • EN 203-1



HDCS-14 [Rev. 1/12]

# LEGEND™ Heavy-Duty Gas Counter-Top Planchas, Plancha Plus & Add-A-Units

Item No. \_\_\_\_\_

Project \_\_\_\_\_

Quantity \_\_\_\_\_

Dimensions in brackets are millimeters

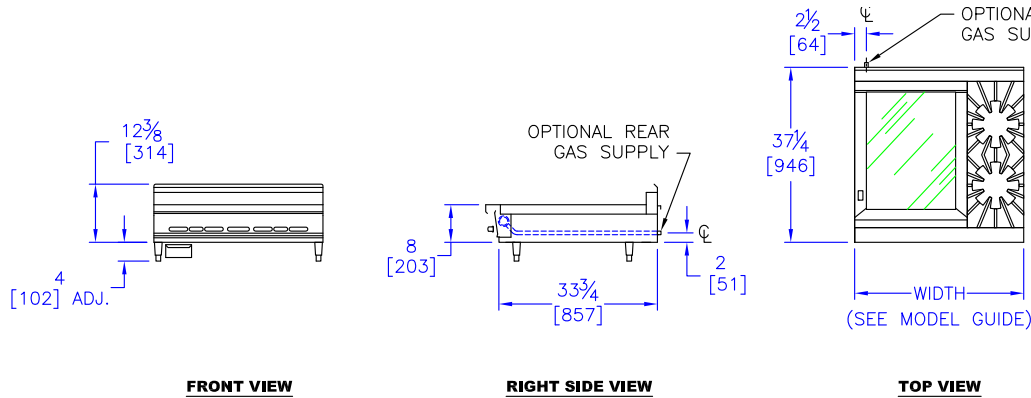

## OPTIONS GUIDE:

### General:

- Equipment Stand [Consult Factory]
- Cast iron ribbon grate - use 20,000 star burner
- 20,000 BTU/hr Star Burner:  front  back

### Flex Connector Kit [1"] NPT:

- 3' (914mm)  4' (1219mm)

### Security Options/Prison Package [Consult Factory]

### Back Panels/Shelves:

- 18" (457mm) high riser
- 6" (152mm) wide stainless steel plate shelf

### For Plancha:

- 20,000 BTU/hr burners with 550°F (288°C) thermostat(s) [Add suffix -T]

- 1" (25mm) thick plate
- Polished chrome-plated cooking surface (requires thermostat option)
- Top grooves to identify zoned heating areas

### Manifolds:

- [Specify left or right rear with pressure regulator]:
- 1" NPT up to 400,000 BTU/hr

### Manifold Cap:

- left side  right side

### Stainless Manifold Cover:

- left side  right side

**Controls:** \*Options include 304 stainless steel burner box assembly and lift out 304 stainless steel drip pans (Open tops only)[see Heavy Duty option page HDS-44]

- \*Electronic rangetop pilot ignition

- \*Flame failure rangetop safety valves
- \*Electronic rangetop pilot ignition & flame failure rangetop safety valves

### Finish:

- Stainless steel back panel
- Stainless steel side panels:
  - left side  right side

### Special Finish

[Consult Factory]

### International Approvals:

- CE - Conformance Européenne - EN203-1  
*Includes flame failure valve option*
- AGA - Australian Gas Association - AS 4563  
*Includes flame failure valve option*
- Canadian Approval

## INSTALLATION REQUIREMENTS & SHIPPING INFORMATION

- Plancha must be installed in accordance with local codes or in their absence with the National Fuel Gas Code: ANSI Z223.1; Natural Fuel Gas Code: CAN/CGA-B149.1 or Propane Installation Code: CAN/CGA-B149.2, as applicable. Compliance with codes is the responsibility of the Owner and Installer.
- An adequate ventilation system is required. Refer to National Fire Protection Association Standard No. 96, "Vapor Removal from Cooking Equipment."
- This appliance is intended for commercial use by professionally trained personnel. NOT intended for Residential Use.
- Specify installation elevation: \_\_\_\_\_ if above 610m.
- GAS INLET SIZE** (All Models): 1-1/4" (32mm) front manifold with 1/2" union on each end provided for battery connection. A properly sized gas pressure regulator must be furnished by the Installer.
- The incoming gas line pressure into the regulator should be 8"-14" w.c. for natural gas, and 12"-14" w.c. for propane gas.

Minimum Clearances	Combustible Construction	Noncombustible Construction
From Back Wall	2" (51mm)	0"
Left & Right Side	6" (152mm)*	0"
With or without 4" (102mm) legs	Suitable for installation on non-combustible counters ONLY	
<b>*15" (381mm) side clearance with open tops</b>		

Models:	Burners	Specify Type of Gas:		Shipping Weight	Shipping Class	Cube (Crated) ft <sup>3</sup> /m <sup>3</sup>	
		<input type="checkbox"/> Natural	<input type="checkbox"/> Propane				
		Manifold Pressure:	6.0" WC*	10.0" WC*			
			BTU/hr (kW)	BTU/hr (kW)			
<b>C18-8PL</b>	1		15,000 (4.4)	15,000 (4.4)	240 lbs (109 kg)	85	6/.2
<b>C24-8PL</b>	2		30,000 (8.8)	30,000 (8.8)	310 lbs (140 kg)	85	9/.25
<b>C36-8PL</b>	3		45,000 (13.2)	45,000 (13.2)	432 lbs (196 kg)	85	14/.4
<b>C36-7PL</b>	4		90,000 (26.4)	90,000 (26.4)	370 lbs (168 kg)	85	14/.4
<b>C36-12PL</b>	2		50,000 (14.6)	50,000 (14.6)	478 lbs (217 kg)	85	14/.4
<b>C36-12EPL</b>	3		55,000 (16.1)	55,000 (16.1)	478 lbs (217 kg)	85	14/.4
<b>C36-13PL</b>	3		75,000 (22)	75,000 (22)	512 lbs (232 kg)	85	14/.4

\*NOTE: Add 5,000 BTU/hr per burner for thermostatically controlled



## THE MONTAGUE COMPANY

1830 Stearman Avenue, Hayward, CA 94545  
800 345-1830 • Fax: 510 785-3342  
www.montaguecompany.com

Due to continuous product improvements, specifications are subject to change without notice.



HDCS-14 [Rev. 1/12]