



LEGEND™ Heavy-Duty Gas 12-36" (305-914mm) Counter-Top Griddle

Item No. _____

Project _____

Quantity _____



Model C24-8 shown

SHORT/BID SPECIFICATION

Counter-top Griddle shall be a Montague **Legend** Add-A-Unit **Model: C** _____ [Specify width: 12" (305mm), 18" (457mm), 24" (610mm) or 36" (914mm)] **-8** [for Manual Control(s)] or **-8T** [for Thermostat Control(s)], unit with a 3/4" (19mm) thick precision ground cook surface, 4" (102mm) high rear splash and tapered side splashes, 2-5/8" (67mm) wide front grease trough with drop to grease drawer and 15,000 BTU/hr or 20,000 BTU/hr (-T Models) burner(s); with stainless steel front, 4" (102mm) high flue riser and 3" (76mm) deep front rail standard; plus all the features listed and options/accessories checked:

STANDARD GRIDDLE FEATURES:

- 3/4" (19mm) thick precision-ground steel cook surface
- 4" (102mm) high backsplash and tapered side-splashes
- 2-5/8" (67mm) wide front grease trough pitched to the grease drop
- Bottom-mounted, slide-out 1-gallon capacity grease drawer - grease can on 12" models
- Standard 15,000 BTU/hr gas burners with standing pilot(s) & gas control valve(s)
- 20,000 BTU/hr gas burner(s) [-T Models] with: thermostat control(s)
- Adjusting bolts for changing griddle plate forward pitch
- Standard has 28" (711mm) deep frytop

STANDARD BASE CONSTRUCTION:

- Satin finish stainless steel front with 3" (76mm) deep front rail
- Stainless steel exterior bottom
- Stainless steel 4" (102mm) rear flue riser
- 4" (102mm) adjustable nickel finish legs
- 1-1/4" front gas manifold with 1/2 union on each end

MODEL GUIDE*

✓	Model No.	Overall Width	Controls	
			Type	Number
	C12-8T	12" (305mm)	Thermostat	1
	C12-8	12" (305mm)	Manual	1
	C18-8T	18" (457mm)	Thermostat	1
	C18-8	18" (457mm)	Manual	2
	C24-8T	24" (610mm)	Thermostat	1
	C24-8	24" (610mm)	Manual	3
	C36-8T	36" (914mm)	Thermostat	2
	C36-8	36" (914mm)	Manual	4

*For wider models see specification sheet HCG-4B

AGENCY APPROVALS

- NSF Listed
- ETL Design Certified to ANSI Z83.11 • CSA 1.8
- CE Approved • EN 203-1



HDCS-9 [Rev. 1/12]

LEGEND™ Heavy-Duty Gas 12-36" (305-914mm) Counter-Top Griddle

Item No. _____

Project _____

Quantity _____

Dimensions in brackets are millimeters

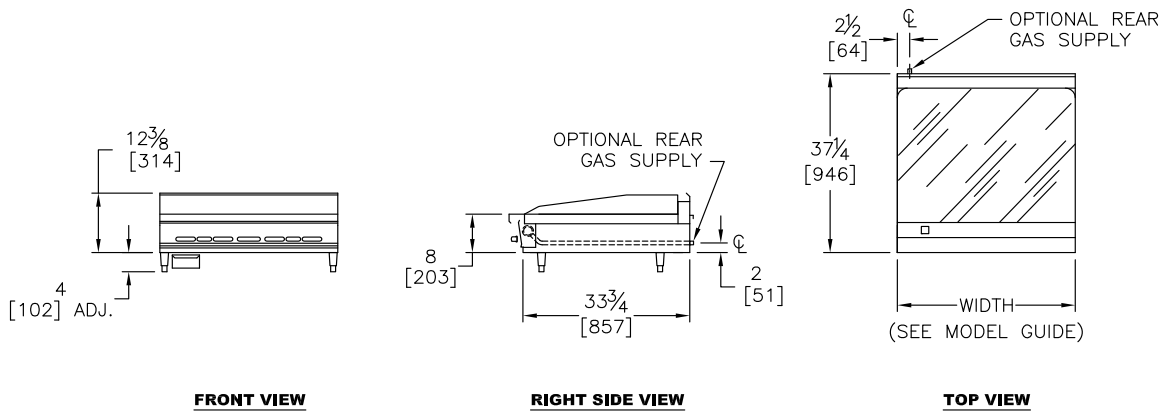

OPTIONS GUIDE:

General:

- 42" (1062mm) Griddle Depth [Add Suffix -40]
- 4" (102mm) special base with grease drawer [M Prefix]
- Equipment Stand [Consult Factory]

Flex Connector Kit [1" NPT]:

- 3' (914mm) 4' (1219mm)

Panels & Shelves:

- Stainless steel back panel
- 18" (547mm) high riser
- 6" (152mm) wide stainless steel plate shelf

Griddle/Fry Top:

- 1" (25mm) thick griddle plate
- 1" (25mm) thick grooved griddle plate

- 1" Chrome griddle (thermostats required)
- 34" (687mm) deep plate [Add Suffix -40]
STD depth 28" (711mm)
- Thermostatically controlled [Add Suffix -T]
- 450° or 550° thermostat options

Manifolds:

[Specify left or right rear with pressure regulator]:

- 1" NPT up to 400,000 BTU/hr

Manifold Cap:

- left side right side

Stainless Manifold Cover:

- left side right side

Controls: [see Heavy Duty option page HDS-44]

- Electronic rangetop pilot ignition
- Flame failure rangetop safety valves

- Electronic rangetop pilot ignition & flame failure rangetop safety valves

Finish:

- Stainless steel back panel
- Stainless steel side panels:
 - left side right side

Special Finish

[Consult Factory]

International Approvals:

- CE - Conformance Européenne - EN203-1
Includes flame failure valve option
- AGA - Australian Gas Association - AS 4563
Includes flame failure valve option
- Canadian Approval

INSTALLATION REQUIREMENTS & SHIPPING INFORMATION

- Griddle must be installed in accordance with local codes or in their absence with the National Fuel Gas Code: ANSI Z223.1; Natural Fuel Gas Code: CAN/CGA-B149.1 or Propane Installation Code: CAN/CGA-B149.2, as applicable. Compliance with codes is the responsibility of the Owner and Installer.
- An adequate ventilation system is required. Refer to National Fire Protection Association Standard No. 96, "Vapor Removal from Cooking Equipment."
- This appliance is intended for commercial use by professionally trained personnel. NOT intended for Residential Use.
- Specify installation elevation: _____ if above 2,000 ft (610m).
- GAS INLET SIZE (All Models): 1-1/4 (32mm) front manifold with 1/2 union on each end provided for battery connection. A properly sized gas pressure regulator must be furnished by the Installer.
- The incoming gas line pressure into the regulator should be 8"-14" w.c. for natural gas, and 12"-14" w.c. for propane gas.

Minimum Clearances	Combustible Construction	Noncombustible Construction
From Back Wall	2" (51mm)	0"
Left & Right Side	6" (152mm)	0"
With or without 4" (102mm) legs	Suitable for installation on non-combustible counters ONLY	

Models:	Burners	Specify Type of Gas:		Shipping Weight	Shipping Class	Cube (Crated) ft ³ /m ³
		<input type="checkbox"/> Natural 6.0" WC	<input type="checkbox"/> Propane 10.0" WC			
		BTU/hr (kW)	BTU/hr (kW)			
C12-8T	1	20,000 (5.9)	20,000 (5.9)	190 lbs (86 kg)	85	4/.1
C12-8	1	15,000 (4.4)	15,000 (4.4)	190 lbs (86 kg)	85	4/.1
C18-8T	2	40,000 (11.7)	40,000 (11.7)	240 lbs (109 kg)	85	7/.2
C18-8	2	30,000 (8.8)	30,000 (8.8)	240 lbs (109 kg)	85	7/.2
C24-8T	3	60,000 (17.6)	60,000 (17.6)	310 lbs (140 kg)	85	9/.25
C24-8	3	45,000 (13.2)	45,000 (13.2)	310 lbs (140 kg)	85	9/.25
C36-8T	4	80,000 (23.4)	80,000 (23.4)	432 lbs (196 kg)	85	14/.4
C36-8	4	60,000 (17.6)	60,000 (17.6)	432 lbs (196 kg)	85	14/.4

Due to continuous product improvements, specifications are subject to change without notice.



THE MONTAGUE COMPANY

1830 Stearman Avenue, Hayward, CA 94545
800 345-1830 • Fax: 510 785-3342
www.montaguecompany.com

