



LEGEND™

Heavy-Duty 24" (610mm) Add-A-Units

(-5,-5S,-559,-559S,-8,-8PL,-9E,-9G, S) Top Series

Item No. _____

Project _____

Quantity _____



Model 24S Shown
(Stainless Steel Work Top)

SHORT/BID SPECIFICATION

Range shall be a Montague **Legend** 24" (610mm) Cabinet Base Model [Specify one]:

- 24-5, 2-12" (305mm) Open Top;
- 24-5S, 2-12" (305mm) Open Top w/ Step-up;
- 24-559, 2-12" (305mm) Combination, Open Top/Hot Top;
- 24-559S, 2-12" (305mm) Combination, Open Top/Hot Top w/ Step-up;
- 24-8, 1-24" (610mm) Frytop, 3/4" thick, manual control;
- 24-8PL, 1-24" (610mm) Plancha, 3/4" thick, manual control;
- 24-9E, 2-12" (305mm) Hot Top, Even Heat;
- 24-9G, 2-12" (305mm) Hot Top, Even Heat;
- 24S, 1-24" (610mm) Stainless Steel Work Top;

OR

Range shall be a Montague **Legend** 24" (610mm) Modular Stand Model [Specify one]:

- M24-5, 2-12" (305mm) Open Top;
- M24-5S, 2-12" (305mm) Open Top w/ Step-up;
- M24-559, 2-12" (305mm) Combination, Open Top/Hot Top;
- M24-559S, 2-12" (305mm) Combination, Open Top/Hot Top w/ Step-up;
- M24-8, 1-24" (610mm) Frytop, 3/4" thick, manual control;
- M24-8PL, 1-24" (610mm) Plancha, 3/4" thick, manual control;
- M24-9E, 2-12" (305mm) Hot Top, Even Heat;
- M24-9G, 2-12" (305mm) Hot Top, Gradient Heat;
- M24S, 1-24" (610mm) Stainless Steel Work Top;

...a 24" (610mm) wide heavy-duty gas-fired Add-A-Unit offered in a wide variety of widths and tops to enhance your Montague Cooking Battery. These units match all Montague **Legend Series** Heavy-Duty Ranges; with stainless steel front, black painted sides and back or stainless steel modular stand, 4" (102mm) high flue riser and 3" (76mm) deep front rail standard; plus all the features listed and options/accessories checked:

MODEL GUIDE			
-5	-5S	-559	-559S
-8	-8PL	-9E & -9G	S

STANDARD CABINET BASE CONSTRUCTION FEATURES:

- Cabinet base with sides, back panel and two shelves
- Satin finish stainless steel front with 3" (76mm) deep front rail
- Other surfaces painted black with electrolytic zinc undercoating
- Even heat hot tops ("E" denotes even heat on hot tops)
- Gradient heat hot tops ("G" denotes front fired gradient heat on hot tops)
- 3/4" (19mm) thick frytops, manual control
- 30,000 BTU/hr open burners
- Stainless steel 4" (102mm) rear flue riser standard
- 6" (152mm) adjustable stainless steel legs standard
- 1-1/4" NPT front gas manifold with 1/2 union on each end

STANDARD MODULAR STAND CONSTRUCTION FEATURES:

- Satin finish stainless steel front with 3" (76mm) deep front rail
- Other surfaces painted black with electrolytic zinc undercoating
- Even heat hot tops ("E" denotes even heat on hot tops)
- Gradient heat hot tops ("G" denotes front fired gradient heat on hot tops)
- 3/4" (19mm) thick frytops, manual control
- 30,000 BTU/hr open burners
- Stainless steel 4" (102mm) rear flue riser standard
- 28" (711mm) high modular stand with stainless steel tubular legs with adjustable bullet feet
- 1-1/4" NPT front gas manifold with 1/2 union on each end

AGENCY APPROVALS:

- NSF Listed
- ETL Design Certified to ANSI Z83.11 • CSA 1.8
- CE Approved • EN 203-1



HDS-45 [Rev. 1/12]

Item No. _____

Project _____

Quantity _____

LEGEND™ Heavy-Duty 24" (610mm) Add-A-Units

(-5, -5S, -559, -559S, -8, -8PL, -9E, -9G, S) Top Series

Dimensions in brackets are millimeters

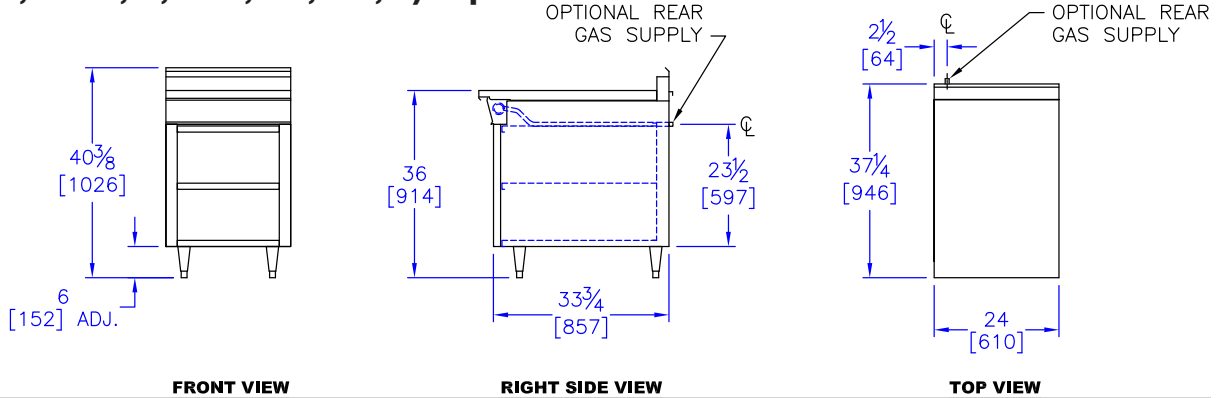

OPTIONS GUIDE:

Open Burner Top Sections:

- 30,000 BTU/hr front lift off star burner with rear 15,000 BTU/hr solid hot top [-59], positioned:
 - Left
 - Right

Top Range:

- 42" (1067mm) range depth [Add Suffix: -40]
- 304 stainless steel burner box assembly

Griddle:

- 450° Thermostatic Control [one for 24" griddle]
- 550° Thermostatic Control [one for 24" griddle]
- 1" (25mm) thick griddle plate
- 1" (25mm) thick grooved griddle plate
- 34" (864mm) deep plate [Add Suffix -40]
- Extending griddle over two ranges [72" max.]
- 42" (1067mm) range depth [Add Suffix: -40]

Back Panels/Shelves:

- 18" (457mm) high back

- Single high shelf
- Double high shelf
- 6" (152mm) wide stainless steel plate shelf
- 8" (203mm) wide stainless steel plate shelf

Manifolds: [Left rear with pressure regulator]:

- 1" NPT up to 400,000 BTU/hr

Manifold Cap:

- left side
- right side

Stainless Manifold Cover:

- left side
- right side

Finish:

- Stainless steel left side panel
- Stainless steel right side panel
- Stainless steel back panel
- Stainless steel shelves and sides

HIGH SHELVES ARE NOT RECOMMENDED FOR MODULAR STAND UNITS.

Special Finish: [Consult factory]

Controls: [see Heavy Duty option page HDS-46]

- Electronic rangetop pilot ignition
- Flame failure rangetop safety valves

General:

- Casters — set of four 5" (127mm) casters
- Flanged feet with holes

Flex Connector Kit [1" NPT]:

- 3' (914mm)
- 4' (1219mm)

Security Options/Prison Package [Consult Factory]

Doors:

- Stainless Steel door for cabinet base

International Approvals:

- CE - Conformance Européenne - EN203-1
Includes flame failure valve option
- Canadian Approval

INSTALLATION REQUIREMENTS & SHIPPING INFORMATION

1. Ranges must be installed in accordance with local codes or in their absence with the National Fuel Gas Code: ANSI Z223.1; Natural Fuel Gas Code: CAN/CGA-B149.1 or Propane Installation Code: CAN/CGA-B149.2, as applicable. Compliance with codes is the responsibility of the Owner and Installer.
2. An adequate ventilation system is required. Refer to National Fire Protection Association Standard No. 96, "Vapor Removal from Cooking Equipment."
3. This appliance is intended for commercial use by professionally trained personnel. NOT intended for Residential Use.
4. Specify installation elevation: _____ if above 2,000 ft (610m).
5. GAS INLET SIZE (All Models): 1-1/4 (32mm) front manifold with 1/2 union on each end provided for battery connection. A properly sized gas pressure regulator must be furnished by the Installer.

Minimum Clearances	Combustible Construction	Noncombustible Construction
From Back Wall*	2" (51mm)	0"
Left & Right Side	15" (381mm)	0"
With 6" (152mm) legs	Suitable for installation on combustible floors	

Models:	Burners	Specify Type of Gas:		Shipping Weight	Shipping Class	Cube (Crated) ft ³ /m ³
		<input type="checkbox"/> Natural Gas Delivery Pressure: 6.0" WC	<input type="checkbox"/> Propane 10.0" WC			
24-5 & M24-5	4	120,000 (35.1)	120,000 (35.1)	285 lbs (113 kg)	85	18.7/.5
24-5S & M24-5S	4	100,000 (29.3)	100,000 (29.3)	300 lbs (168 kg)	85	18.7/.5
24-559 & M24-559	4	90,000 (26.4)	90,000 (26.4)	300 lbs (168 kg)	85	18.7/.5
24-559S & M24-559S	4	90,000 (26.4)	90,000 (26.4)	310 lbs (123 kg)	85	18.7/.5
24-8 & M24-8	3	45,000 (13.2)	45,000 (13.2)	335 lbs (123 kg)	85	21.4/.6
24-8PL & M24-8PL	2	30,000 (8.8)	30,000 (8.8)	335 lbs (123 kg)	85	18.7/.5
24-9E & M24-9E	2	40,000 (11.7)	40,000 (11.7)	260 lbs (123 kg)	85	18.7/.5
24-9G & M24-9G	2	40,000 (11.7)	40,000 (11.7)	260 lbs (123 kg)	85	18.7/.5
24S & M24S	0	0	0	155 lbs (66 kg)	85	18.7/.5

*Add 15,000 BTU/hr (4.5 kW) for 42" (1067mm) deep Griddle Top [-40] and thermostatically controlled griddle. Entry Clearance: 30" (762mm) uncrated, with legs removed [All Models]



THE MONTAGUE COMPANY

1830 Stearman Avenue, Hayward, CA 94545

800 345-1830 • Fax: 510 785-3342

www.montaguecompany.com

Due to continuous product improvements, specifications are subject to change without notice.



HDS-45 [Rev. 1/12]