



# VECTAIRE™ Single Deck, Full-Size Gas Convection Oven

Item No. \_\_\_\_\_

Project \_\_\_\_\_

Quantity \_\_\_\_\_

## 70 & 115 Series



Model 115A Shown with optional casters

### SHORT/BID SPECIFICATION

Convection oven shall be a Montague **Vectaire** Model [Specify one]:

- 70** with 70,000 BTU/hr output
- 115** with 115,000 BTU/hr output

[Specify one]:

- A** conventional vertical doors
- Z** open up/down horizontal doors

[Specify one]:

- E** [Suffix] snap action 200-500°F (93-260°C) thermostat with burner-ON indicator light
- G** [Suffix] throttling-type gas 150-500°F (66-260°C) thermostat with burner-ON indicator light

...plus automatic fan shutoff, cool-down mode, momentary-ON light switch and 60 minute electric timer; and a porcelainized steel oven interior with: one speed fan, nine rack positions, five bright nickel racks with rack stops and no-tip guides standard; ball bearing mounted 50-50 split double doors with double pane viewing windows, and black gusseted-style legs; plus all the features listed and options/accessories checked:

### MODEL-PAN/RACK GUIDE:

Model No.	Door Type	Racks Positioned	Pan Loading		Rack Spacing	
			Length	Sideways	5-racks	9-racks
70A	Vertical	5/9	Yes	Yes	3-3/8" (86mm)	1-1/2" (38mm)
70Z	Horizontal	5/9	Yes	Yes	3-3/8" (86mm)	1-1/2" (38mm)
115A	Vertical	5/9	Yes	Yes	3-3/8" (86mm)	1-1/2" (38mm)
115Z	Horizontal	5/9	Yes	Yes	3-3/8" (86mm)	1-1/2" (38mm)

\*18" x 26" (457 x 660mm) sheet pans

### OVEN INTERIOR CONSTRUCTION:

- Porcelainized 16-gauge steel interior
- 27" (686mm) (Bakery Depth) interior accepts pans lengthwise or sideways
- Nine-position bright nickel rack guides
- Five bright nickel pan racks, with rack-stop and no-tip guides standard
- 4" (102mm) of insulation compressed to 2" (51mm) with metal sheathing
- Two covered interior lights

### BURNERS & BLOWER SYSTEMS:

- Indirect-heated "muffled oven" design
- Fully welded dual steel pipe and cast iron burner
- 16-gauge stainless steel removable burner baffle
- Dependable standing pilot ignition
- Blower with space saving, 3/4-horsepower single-speed pancake motor

### EXTERIOR CONSTRUCTION FEATURES:

- Satin finish stainless steel front
- Aluminized steel top, sides, back and flue deflector
- Choice of vertical [A] or horizontal [Z] 50-50 split doors
- Ball bearing mounted 50-50 split double doors
- Double pane thermal viewing windows [vertical doors only]
- Single tubular grab handle opens both doors
- Horizontal door models [Z] provide pan loading/unloading surface
- Black painted-steel gusset-type legs, with adjustable bullet feet
- 6' (1829mm) power cord with grounded NEMA 5-15P plug

### CONTROL FEATURES:

- Power/fan speed control (single speed fan)
- Automatic fan cutoff when door is opened (except in cool-down)
- Momentary-ON interior light switch
- 60-minute electric countdown timer with alarm
- E Suffix:**
  - Snap-action electric 150-500°F (66-260°C) thermostat
- G Suffix:**
  - Throttling-type gas thermostat with 150-500°F (66-260°C) range

### AGENCY APPROVALS

- NSF Listed
- CSA Design Certified to ANSI Z83.11 • CSA 1.8



VCO-5 [Rev. 1/12]

# VECTAIRE™ Single Deck, Full-Size Gas Convection Oven

Item No. \_\_\_\_\_

Project \_\_\_\_\_

Quantity \_\_\_\_\_

## 70 & 115 Series

Dimensions in brackets are millimeters

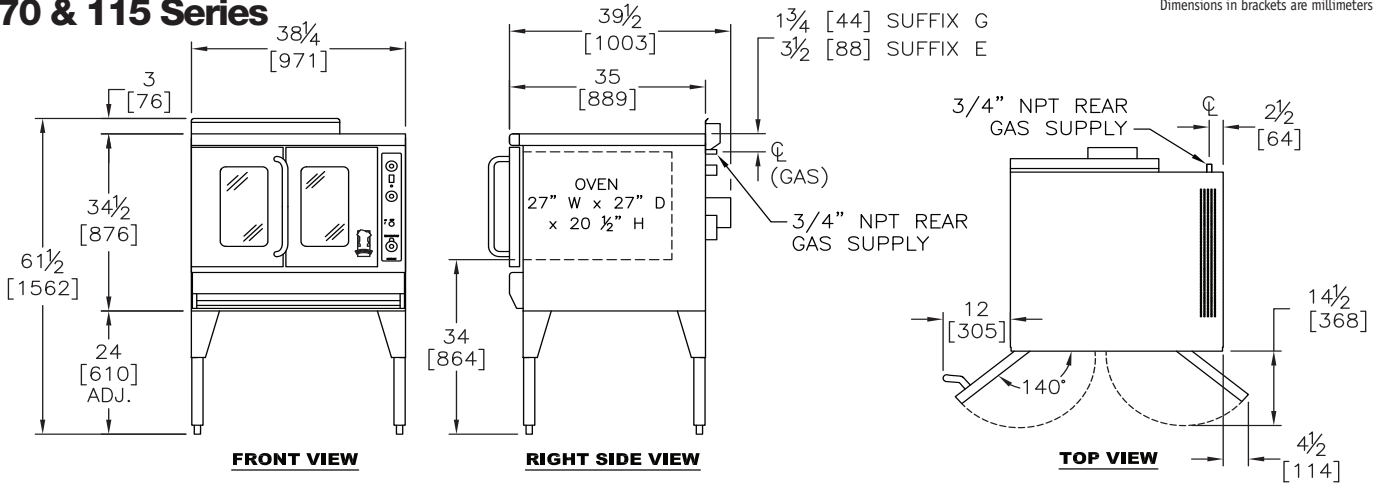

### OPTIONS GUIDE:

#### Installation Alternatives:

- Stacking Kit (for bottom unit)
- Stem casters for gusset-style legs; set of 4 ea., 5" (127mm)
- Modular Stand (open base) with 4" (102mm) frame, stainless steel front, lower shelf and 26" (660mm) stainless steel legs, plus:
  - Stem Casters 3-1/2" (89mm)
  - Side and back to match oven
  - 9-position removable pan slides for stand
- Heat Shield Kit [See minimum clearances]
- Flexible Gas Quick-Disconnect Kit [with restraint]
- Stainless steel downdraft diverter

#### Electric, Controls & Motor Alternatives:

- [\*Extra cost, includes 3-phase motor]
- Electronic ignition [Suffix -EI, A Models only]
- 2-speed motor [1-phase only]
- Solid state thermostat (vertical doors only)
- 120-volt, 1-Phase, 60 Hz 7.4 AMP w/6' (1.8m) cord
- 208-240-Volt, 1-Phase, 60 HZ, 4.1 AMP, 3-wire
- \*208-240-Volt, 3-phase, 60 HZ, 3.0 AMP, 4-wire
- \*440-480-Volt, 3-phase, 60 Hz, 1.4 AMP, 4-wire

#### Finish:

- Full stainless steel oven interior [-ASC suffix]
- Stainless steel flue deflector
- Stainless steel gusset-style legs
- Stainless steel louvered back panel

#### Racks & Security:

- Stainless steel drip tray
- Extra Racks: \_\_\_\_\_ ea. std. \_\_\_\_\_ ea. heavy-duty
- 11-position rack guides [set of two]
- Security Options [Consult Factory]
- Solid Doors [Vertical Doors Only]
- Independent doors

### INSTALLATION REQUIREMENTS & SHIPPING INFORMATION

- Ovens must be installed in accordance with local codes or in their absence with the National Fuel Gas Code: ANSI Z223.1; Natural Fuel Gas Code: CAN/CGA-B149.1 or Propane Installation Code: CAN/CGA-B149.2, as applicable. Compliance with codes is the responsibility of the Owner and Installer.
- An adequate ventilation system is required. Refer to National Fire Protection Association Standard No. 96, "Standard for Ventilation and Fire Protection of Commercial Cooking Operations."
- This appliance is intended for commercial use by professionally trained personnel. NOT intended for Residential Use.
- Specify installation elevation:** \_\_\_\_\_ if above 2000 feet (610m).
- GAS INLET SIZE (All Models):** One 3/4" NPT gas connections provided at left-rear. One 3/4" NPT gas pressure regulators are provided and must be installed (by others) when unit is connected to gas supply.
- The incoming gas line pressure into the regulator should be 8"-14" w.c. for natural gas, and 12"-14" w.c. for propane gas.

Minimum Clearances	Combustible Construction	Noncombustible Construction
From Back Wall	6" (152mm)	5" (127mm)
Left & Right Side	6" (152mm)	0"
With 24" (610mm) legs	Suitable for installation on combustible floors	

Specify Type of Gas:		<input type="checkbox"/> Natural	<input type="checkbox"/> Propane	Shipping Weight	Shipping Class	Cube (Crated) ft <sup>3</sup> /m <sup>3</sup>
Gas Delivery Pressure:		3.5" WC	10.0" WC			
Models:	Burners	BTU/hr (kW)	BTU/hr (kW)			
<b>70 Series</b>	1	70,000 (20.5)	70,000 (20.5)	560 lbs (254 kg)	70	37/1
<b>115 Series</b>	1	115,000 (33.7)	90,000 (26.4)	560 lbs (254 kg)	70	37/1
With Gusset style legs:				560 lbs (254 kg)	70	37/1
Modular Stand, shelf & rack add:				90 lbs (41 kg)	70	21/6

Entry Clearance: 34-3/4" (883mm) uncrated

Due to continuous product improvements, specifications are subject to change without notice.



## THE MONTAGUE COMPANY

1830 Stearman Avenue, Hayward, CA 94545  
 800 345-1830 • Fax: 510 785-3342  
 www.montaguecompany.com



VCO-5 [Rev. 1/12]