



VECTAIRE™ Half-Size Electric Convection Oven

Item No. _____

Project _____

Quantity _____

2EK8 Series



Model 2EK8(O)A

SHORT/BID SPECIFICATION

Convection oven(s) shall be a Montague *Vectaire* half-size electric Model [Specify one]:

- 2EK8(N)A** a double deck unit with left door swing and 6" (152mm) legs
- 2EK8(O)A** a double deck unit with right door swing and 6" (152mm) legs

...with three tubular heating elements (per section); a stainless steel oven interior with two speed fan, nine rack positions, five bright nickel racks with rack stops and no-tip guides standard; single door(s) with double pane viewing window; plus all the features listed and options/accessories checked:

OVEN INTERIOR CONSTRUCTION:

- All stainless steel oven interior
- Nine-position bright nickel rack guides
- Five bright nickel pan racks, with rack-stop and no-tip guides standard
- 4" (102mm) of insulation compressed to 2" (51mm) with metal sheathing

HEATING ELEMENTS & BLOWER SYSTEM:

- Three 2.6-kW heating elements (per section)
- Blower with 1/2-horsepower single-speed motor
- Double pane thermal viewing window

MODEL-DOOR SWING-PAN/RACK GUIDE:

✓	Model No.	Ovens	Door Swing	Racks/Positions	Rack Spacing	
					5-racks	9-racks
	2EK8(N)A	double	left	10/18	3-3/8" (86mm)	1-1/2" (38mm)
	2EK8(O)A	double	right	10/18	3-3/8" (86mm)	1-1/2" (38mm)

EXTERIOR CONSTRUCTION FEATURES:

- Satin finish stainless steel front, sides and top
- Ball bearing mounted single door, double pane thermal viewing window
- Tubular grab-bar handle with insulated comfort grip
- Durable, adjustable door gasket
- 4" (102mm) stainless steel base frame & 6" (152mm) legs with adjustable bullet feet

CONTROL FEATURES (EACH DECK):

- Power/fan oven cool-down mode switch (two speed fan)
- Snap-action electric thermostat with 200-500°F (93-260°C) range
- Power indicator light
- 60-minute electric countdown timer with alarm
- Burner indicator light
- Moisture vent

AGENCY APPROVALS

- NSF Listed
- UL Listed (ANSI/UL-197)



VC0-16 [Rev. 1/12]

Item No. _____

Project _____

Quantity _____

VECTAIRE™ Half-Size Electric Convection Oven

2EK8 Series

Dimensions in brackets are millimeters

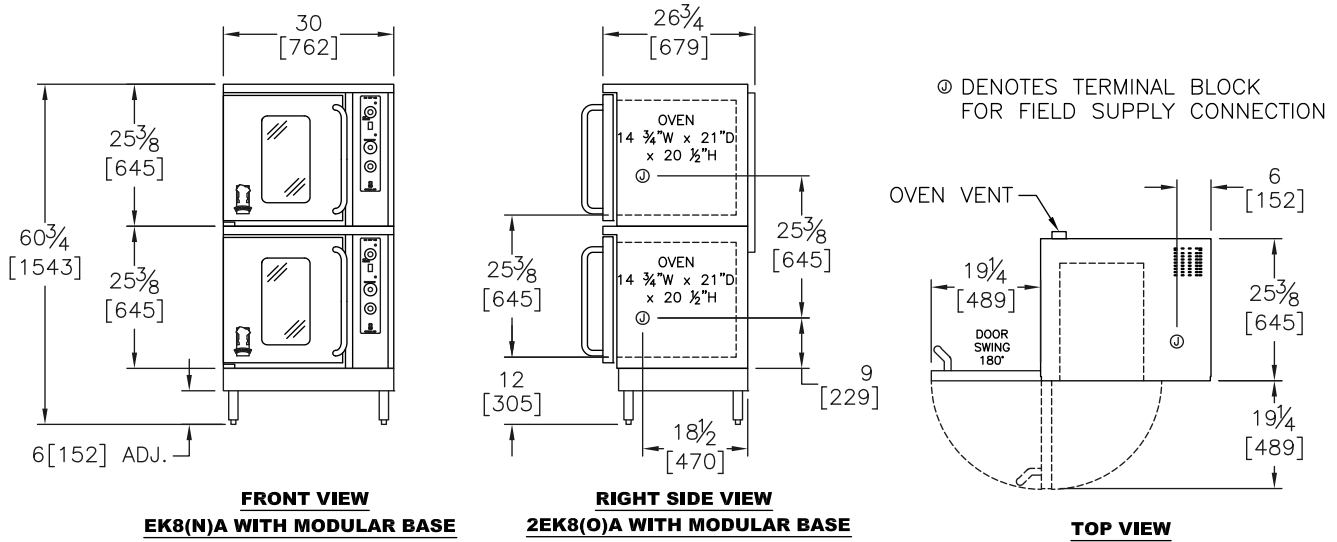

OPTIONS GUIDE:

Electric & Motor Alternatives:

- Two speed fan motor [208/240]

Racks & Security:

- Extra Racks: ____ ea.
- Rack guide for Gastronome Pans GN 1/1
- Solid Doors [in place of windows]
- Security Options [Consult Factory]
- 11-position rack guides

INSTALLATION REQUIREMENTS & SHIPPING INFORMATION

1. Oven must be installed in accordance with local codes or in their absence with the National Electric Code: ANSI/NFPA 70. Compliance with codes is the responsibility of the Owner and Installer.
2. An adequate ventilation system is required. Refer to National Fire Protection Association Standard No. 96, "Vapor Removal from Cooking Equipment."
3. This appliance is intended for commercial use by professionally trained personnel. NOT intended for Residential Use.
4. Two separate electric connections are required on double deck 2EK8 Models. Individual terminal blocks provided inside each oven. (See Diagram)

Minimum Clearances	Combustible Construction	Noncombustible Construction
From Back Wall	0"	0"
Left & Right Side*	0"	0"
With 6" (152mm) legs [2EK8]	Suitable for installation on combustible floors	

Electric Requirements* — Per Oven/Deck

Voltage	Phase	Hz	Total kW	Nominal AMP/Line			Minimum Circuit Capacity
				L1	L2	L3	
208	1	60	7.9	38			48
240	1	60	7.9	33			48
208	3	60	7.9	26	26	24	33
240	3	60	7.9	23	23	21	33

*Other Voltage/Hz models available. Consult factory.

Shipping Information:

Models	Weight	Shipping Class	Cube (Crated) ft ³ /m ³
2EK8	515 lbs (233 kg)	70	2 x 15/.4
Entry clearance 26" (660mm) uncrated			



THE MONTAGUE COMPANY

1830 Stearman Avenue, Hayward, CA 94545
800 345-1830 • Fax: 510 785-3342
www.montaguecompany.com

Due to continuous product improvements, specifications are subject to change without notice.

