



# VECTAIRE™ Double Deck, Bakery Depth Electric Convection Ovens

Item No. \_\_\_\_\_

Project \_\_\_\_\_

Quantity \_\_\_\_\_

## 2EK15A Series



Model 2EK15A

### SHORT/BID SPECIFICATION

Convection oven shall be Montague *Vectaire* full-size, double deck electric Model:

- 2EK15A** (six 2.5-kW heating elements grouped in two sets) — **bakery depth 15-kW** units with 6" (152mm) stainless steel legs

...with a porcelainized steel oven interiors with one-speed [bakery] or two-speed [standard] fan, nine rack positions, five bright nickel racks with rack stops and no-tip guides standard; ball bearing mounted 50-50 split doors with double pane viewing windows, plus all the features listed and options/accessories checked:

### OVEN INTERIOR CONSTRUCTION [EACH DECK]:

- Porcelainized steel cooking compartment
- Nine-position bright nickel rack guides
- Five bright nickel pan racks, with rack-stop and no-tip guides standard
- Two covered interior lights
- 4" (102mm) of insulation compressed to 2" (51mm) with metal sheathing

### HEATING ELEMENTS & BLOWER SYSTEM [EACH DECK]:

- Six 2.5-kW heating elements grouped in two sets
- Blower with 3/4-horsepower two-speed motor

### MODEL-PAN/RACK GUIDE (For Each Deck):

✓	Model No.	Oven Depth	Racks/ Positions	Rack Spacing	
				5-racks	9-racks
	<b>2EK15A</b>	Bakery*	5/9	3-3/8" (86mm)	1-1/2" (38mm)

\*18" x 26" (457 x 660mm) sheet pans length or sideways

### EXTERIOR CONSTRUCTION FEATURES:

- Satin finish stainless steel front, sides and top
- Ball bearing mounted 50-50 double doors
- Tubular grab-bar handle with insulated comfort grip
- Double pane thermal viewing windows
- Durable, adjustable door gasket
- 6" (152mm) height adjustable stainless steel legs

### CONTROL FEATURES (EACH DECK):

- Power/fan control
- Automatic fan cutoff when door is opened (except in cool-down)
- Power indicator light
- Momentary-ON interior light switch
- Snap-action electric thermostat with 200-500°F (93-260°C) range
- Burner indicator light
- 60-minute electric countdown timer with alarm
- Moisture vent

### AGENCY APPROVALS

- NSF Listed
- UL Listed (ANSI/UL-197)



VC0-11 [Rev. 1/12]

# VECTAIRE™ Double Deck, Full-Size, Bakery Depth Electric Convection Ovens

## 2EK15A Series

Item No. \_\_\_\_\_

Project \_\_\_\_\_

Quantity \_\_\_\_\_

Dimensions in brackets are millimeters

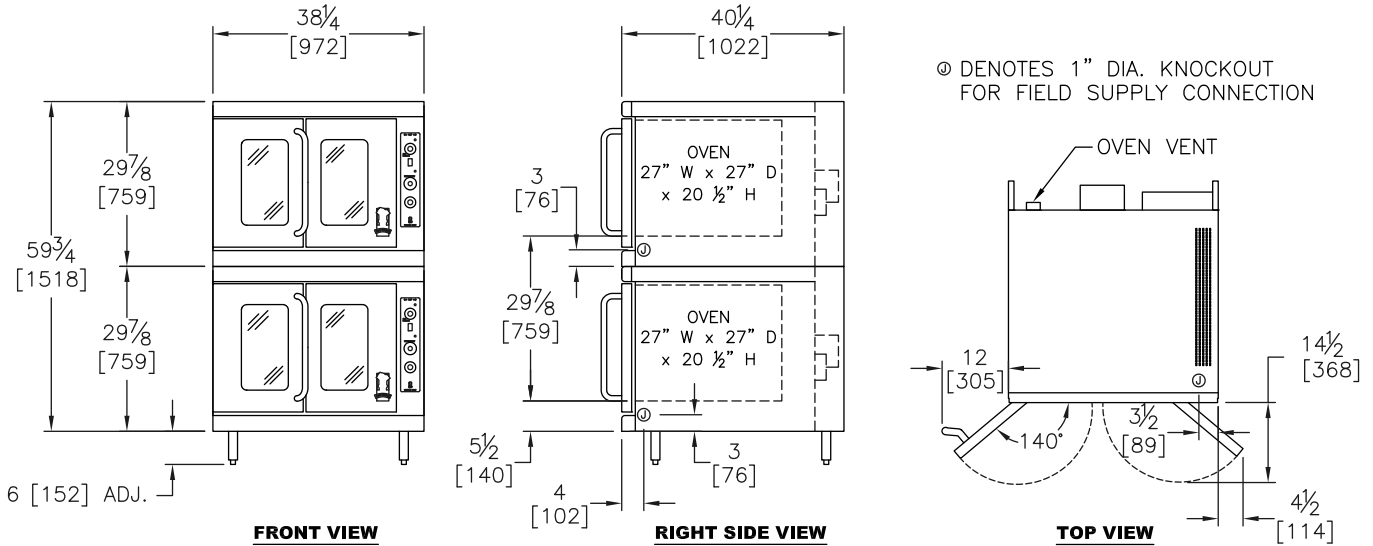

### OPTIONS GUIDE:

#### Installation Alternatives:

- Casters [Set of four]:
- Casters [Set of four 5" (127mm) plate casters]
- 3-1/2" (89mm)
- 1" (25mm) Toe base for curb mounting
- Independent doors

#### Finish:

- Full stainless steel oven interiors [-ASC suffix]
- Stainless steel exterior bottom
- Stainless steel louvered back panel

#### Racks & Security:

- Stainless steel drip trays: \_\_\_\_ ea.
- Extra Racks: \_\_\_\_ ea. std.;
- \_\_\_\_ ea. heavy-duty
- 11-position rack guides [set of four]
- Solid Doors [in place of windows]
- Security Options [Consult Factory]

### INSTALLATION REQUIREMENTS & SHIPPING INFORMATION

- Oven must be installed in accordance with local codes or in their absence with the National Electric Code: ANSI/NFPA 70. Compliance with codes is the responsibility of the Owner and Installer.
- Each oven deck requires a separate electric power connection. 1" (25mm) knockout provided.
- An adequate ventilation system is required. Refer to National Fire Protection Association Standard No. 96, "Vapor Removal from Cooking Equipment."
- This appliance is intended for commercial use by professionally trained personnel. NOT intended for Residential Use.

Minimum Clearances	Combustible Construction	Noncombustible Construction
From Back Wall	0"	0"
Left & Right Side	0"	0"
<b>Unit must be mounted on legs or casters.</b>		

#### Electric Requirements [For Each Deck]\*

Voltage	Phase	Hz	Total kW 2EK15A	Nominal AMP/Line 2EK15A			Minimum Circuit Capacity 2EK15A
				L1	L2	L3	
208	1	60	15.15	78			98
240	1	60	15.15	69			98
208	3	60	15.15	43	43	41	54
240	3	60	15.15	40	40	36	54
480	3	60	15.15	22	22	19	27

\*Other Voltage/Hz models available. Contact factory.

#### Shipping Information:

Models	Weight	Shipping Class	Cube (Crated) ft <sup>3</sup> /m <sup>3</sup>
<b>2EK15A</b>	930 lbs (422 kg)	70	2 x 37/1
Entry clearance 30" (762mm) uncrated			



## THE MONTAGUE COMPANY

1830 Stearman Avenue, Hayward, CA 94545  
 800 345-1830 • Fax: 510 785-3342  
 www.montaguecompany.com

Due to continuous product improvements, specifications are subject to change without notice.



VCO-11 [Rev. 1/12]