



# LEGEND™ Heavy-Duty Gas Infrared, Overfired Broiler on Oven Base

Item No. \_\_\_\_\_

Project \_\_\_\_\_

Quantity \_\_\_\_\_

## 136W36 or V136W36 Model



Model 136W36

### SHORT/BID SPECIFICATION

Broiler shall be a Montague *Legend* Heavy Duty Oven-Mounted Overfired Model:

- 136W36**, with a front-vented 40,000 BTU/hr conventional oven with counterweighted door, porcelainized steel interior, three-position rack guides and one wire pan rack standard
- V136W36**, with an indirect-fired 45,000 BTU/hr convection oven with counterweighted door, porcelainized steel interior, five-position rack guides and three wire pan racks standard

...supporting a gas-fired, infrared broiler with two 42,000 BTU/hr cast iron burners with individual controls, heating ceramic radiants mounted above a counter-balanced, height-adjustable, chrome-plated steel cooking grid that is drawer-mounted for easy pull-out access, with a full width grease deflector and large capacity left-front-mounted grease container; supporting a top-mounted warming/finishing oven heated by the broiler; plus all the features listed and options/accessories checked:

### BURNER/RADIANT SYSTEM FEATURES:

- 42,000 BTU/hr cast-iron burners
- Ceramic radiants for uniform infrared heating
- Individual burner controls
- Standing pilot for automatic ignition

### ROLL-OUT BROILER/GRID FEATURES:

- Two chrome-plated steel grid sections
- Counter-balanced grid assembly for easy height adjustment
- Infinite grid height adjustment from 2" to 5" (51 to 127mm)
- Positive locking lift handle with cool ball-style grip
- Quiet, ball bearing mounted pull-out grid assembly
- Shielded horizontal grab-bar handle

### MODEL GUIDE

✓	Model No.	Oven Type	Cooking Area
	136W36	With Standard Oven	27" x 27" (686 x 686mm)
	V136W36	With Convection Oven	27" x 27" (686 x 686mm)

### UPPER WARMING OVEN FEATURES [BOTH MODELS]:

- Handy warming/finishing oven mounted above broiler
- Efficiently uses broiler heat for warming
- 26-1/2" wide x 8" high x 24" deep (673 x 203 x 610mm) compartment
- High temperature aluminized compartment interior
- One nickel-plated rack
- Counter-balanced tilt-back door

### STANDARD (136W36 MODEL) OVEN FEATURES:

- 26 5/8" wide x 15" high x 28" deep (660 x 381 x 771mm) cooking compartment
- Accepts 18" x 26" (457 x 660mm) pans sideways or lengthwise
- Front-venting oven design for more even cooking
- Heavy-duty counterweighted oven door — no springs
- Three-position adjustable nickel-plated rack supports, with one rack standard
- Interior panels and door porcelain lined for long life & easy cleaning
- Low-to-500°F (260°C) thermostat mounted in insulated cool zone
- 40,000 BTU/hr cast iron burner with automatic ignition safety pilot

### VECTAIRE (V136W36 MODEL) OVEN FEATURES:

- 26 5/8" wide x 15" high x 22-1/4" deep (660 x 381 x 565mm) cooking compartment
- Muffled, indirect-fired design with blower, for fast, even cooking
- Heavy-duty counterweighted oven door — no springs
- Five-position adjustable nickel-plated rack supports, with three racks standard
- Interior panels and door porcelain lined for long life & easy cleaning
- Low-to-500°F (260°C) thermostat mounted in insulated cool zone
- 45,000 BTU/hr cast iron burner with automatic ignition safety pilot

### STANDARD CONSTRUCTION FEATURES:

- Satin finish stainless steel front & top
- Other surfaces painted black with electrolytic zinc undercoating
- 2" (51mm) high broiler flue riser
- Full width grease deflector under rollout grid
- Extra-large capacity front-hanging, removable grease container
- 6" (152mm) legs with height-adjustable bullet feet
- 1-1/4" NPT front gas manifold with 1/2 union on each end

### AGENCY APPROVALS

- CSA Design Certified to ANSI Z83.11 • CSA 1.8
- Australian Gas Association Certificate Number 7466
- NSF Listed
- CE Approved EN 203-1



HDB-14 [Rev. 1/12]

# LEGEND™ Heavy-Duty Gas Infrared, Overfired Broiler on Oven Base

Item No. \_\_\_\_\_

Project \_\_\_\_\_

Quantity \_\_\_\_\_

Dimensions in brackets are millimeters

## 136W36 or V136W36 Model [127] MIN.

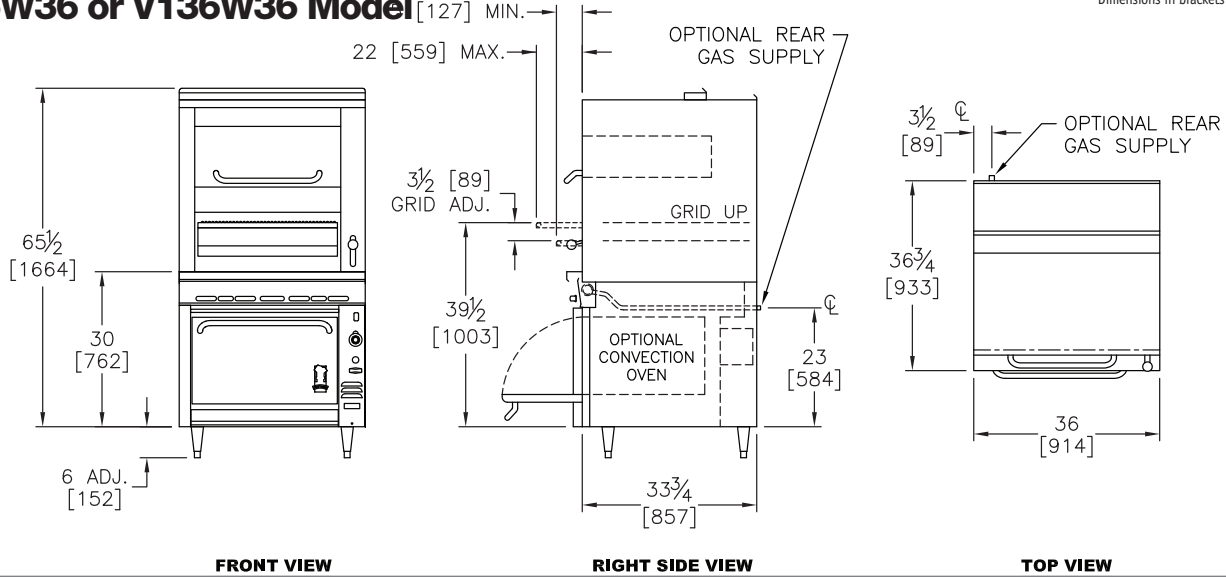

### OPTIONS GUIDE:

#### Finish:

- Stainless steel left side panel:
  - full  upper half
- Stainless steel right side panel:
  - full  upper half
- Stainless steel back panel
- Stainless steel top

#### General:

- Casters — set of four 5" (127mm) casters
- Flex Connector Kit [1"] NPT:

- 3' (914mm) long  4' (1219mm) long
- Security Options/Prison Package [Consult Factory]

#### International Approvals:

- CE-Conformite Europeene  
Includes Flame Failure Valve Option
- AGA-Australian Gas Association  
Includes Flame Failure Valve Option
- Canadian Approval

#### Oven:

- Cast iron oven bottom – 2-piece [136W36 only]
- Extra oven racks: \_\_\_\_ ea.
- 42" (1067mm) deep oven [Add Suffix: -40]

#### Manifolds: [Left rear with pressure regulator]:

- 1" NPT
- Manifold Cap:**  left side  right side
- Stainless Manifold Cover:**  left side  right side

### INSTALLATION REQUIREMENTS & SHIPPING INFORMATION

- Broilers must be installed in accordance with local codes or in their absence with the National Fuel Gas Code: ANSI Z223.1; Natural Fuel Gas Code: CAN/CGA-B149.1 or Propane Installation Code: CAN/CGA-B149.2, as applicable. Compliance with codes is the responsibility of the Owner and Installer.
- An adequate ventilation system is required. Refer to National Fire Protection Association Standard No. 96, "Standard for Ventilation and Fire Protection of Commercial Cooking Operations."
- This appliance is intended for commercial use by professionally trained personnel. NOT intended for Residential Use.
- Specify installation elevation: \_\_\_\_\_ if above 2000 feet (610m).
- GAS INLET SIZE (All Models):** 1-1/4" front manifold with 1/2 unions on each end provided for battery connection. A properly sized gas pressure regulator must be furnished by the Installer.
- The incoming gas line pressure into the regulator should be 8"-14" w.c. for natural gas, and 12"-14" w.c. for propane gas.

Minimum Clearances	Combustible Construction	Noncombustible Construction
From Back Wall	6" (152mm)	0"
Left & Right Side	6" (152mm)	0"
<b>With 6" (152mm) legs, suitable for use on combustible floor.</b>		

Specify Type of Gas:		<input type="checkbox"/> Natural	<input type="checkbox"/> Propane	Shipping Weight	Shipping Class	Cube (Crated) ft <sup>3</sup> /m <sup>3</sup>
Manifold Pressure:		6.0" WC	10.0" WC			
Models:	Burners	BTU/hr* (kW)	BTU/hr* (kW)			
<b>136W36</b>	3	124,000 (36.3)	124,000 (36.3)	816 lbs (370 kg)	85	65/1.8
<b>V136W36</b>	3	129,000 (37.8)	129,000 (37.8)	891 lbs (404 kg)	85	65/1.8

\*Total, broiler & oven burners

Uncrated entry clearance: 36-1/4" (921mm)

Due to continuous product improvements, specifications are subject to change without notice.



## THE MONTAGUE COMPANY

1830 Stearman Avenue, Hayward, CA 94545

800 345-1830 • Fax: 510 785-3342

www.montaguecompany.com



HDB-14 [Rev. 1/12]