



LEGEND™ Heavy-Duty 36" (914 mm) Stainless Steel Work Top

Item No. _____

Project _____

Quantity _____

136S, V136S, 36S, M36S



Model 136S shown

SHORT/BID SPECIFICATION

Unit shall be a Montague **Legend** Stainless Steel Work Top Model [Specify one]:

- 136S**, with front vented 40,000 BTU/hr standard oven with counterweighted door, porcelainized steel interior, four-position rack guides and one wire pan rack standard;
- V136S**, with indirect-fired 45,000 BTU/hr convection oven with counterweighted door, porcelainized steel interior, five-position rack guides and three wire pan racks standard;
- 36S**, with open front cabinet base with two shelves;
- M36S**, with 28" (711mm) high modular stand with stainless steel tubular legs;

...a 36" (914 mm) wide heavy duty range match unit with stainless steel work top and stainless steel front, black painted sides and back, or stainless steel modular stand, 4" (102 mm) high flue riser; plus all the features listed and options/accessories checked:

WORK TOP FEATURES:

One 36" wide x 31" deep (914 mm x 787mm) work top:

- Heavy-duty one-piece stainless steel work top

MODEL GUIDE			
✓	Model No.	Base Style/Type	Top
	136S	Standard Oven	Stainless Steel Work Top
	V136S	Convection Oven	Stainless Steel Work Top
	36S	Cabinet Base	Stainless Steel Work Top
	M36S	Modular Stand	Stainless Steel Work Top

STANDARD (136S MODEL) OVEN FEATURES:

- 26" wide x 28-1/4" deep x 15" high (660 x 718 x 381 mm) cooking compartment
- Accepts 18" x 26" (457 x 660 mm) pans sideways or lengthwise
- Front venting oven design for more even cooking
- Heavy duty counterweighted oven door — no springs!
- Four-position adjustable nickel-plated rack guides, with one rack standard
- Interior panels and door porcelain lined for long life & easy cleaning
- Low-to-500°F (260°C) thermostat mounted in insulated cool zone
- 45,000 BTU/hr cast iron burner with automatic ignition safety pilot
- 1-1/4" NPT front gas manifold with 1/2 union on each end

CONVECTION (V136S MODEL) OVEN FEATURES:

- 26-5/8" wide x 22-1/4" deep x 15" high (676 x 565 x 381 mm) cooking compartment
- Muffled, indirect fired design with blower for fast-even cooking
- Heavy duty counterweighted oven door — no springs!
- Five position adjustable nickel-plated rack guides, with three racks standard
- Interior panels and door porcelain lined for long life & easy cleaning
- Low-to-500°F (260°C) thermostat mounted in insulated cool zone
- 45,000 BTU/hr cast iron burner with automatic ignition safety pilot
- 1-1/4" NPT front gas manifold with 1/2 union on each end

CABINET BASE (36S) CONSTRUCTION FEATURES:

- Satin finish stainless steel front
- Heavy one-piece stainless steel work top
- Other surfaces painted black with electrolytic zinc undercoating
- Stainless steel 4" (102 mm) rear flue riser standard
- 6" (152 mm) stainless steel legs with adjustable bullet feet
- 28" (711mm) stainless steel tubular legs standard with M36-16 Model
- 1-1/4" NPT front gas manifold with 1/2 union on each end

MODULAR STAND (M36S) CONSTRUCTION FEATURES:

- Satin finish stainless steel front
- Heavy one-piece stainless steel work top
- Other surfaces painted black with electrolytic zinc undercoating
- Stainless steel 4" (102 mm) rear flue riser standard
- 6" (152 mm) stainless steel legs with adjustable bullet feet
- 1-1/4" NPT front gas manifold with 1/2 union on each end

STANDARD WARRANTY:

- One Year, Parts & Labor
- Lifetime Warranty on Oven Door

AGENCY APPROVALS

- NSF Listed
- ETL Design Certified to ANSI Z83.11



HDS-33 [Rev. 01/10]

LEGEND™ Heavy-Duty 36" (914 mm) Stainless Steel Work Top

136S, V136S, 36S, M36S

Item No. _____

Project _____

Quantity _____

Dimensions in brackets are millimeters

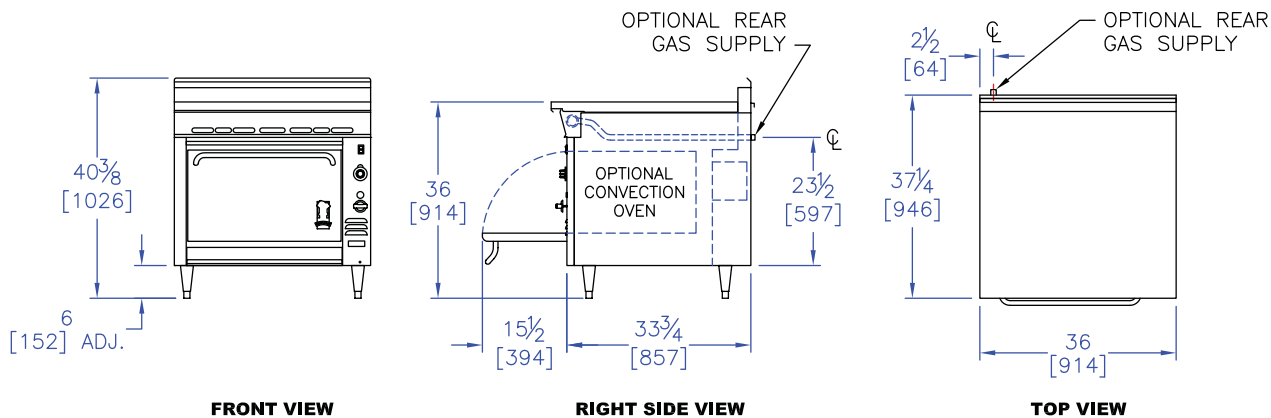

OPTIONS GUIDE:

Finish:

- Stainless steel left side panel
- Stainless steel right side panel
- Stainless steel back panel
- Stainless steel exterior bottom

Back Panels/Shelves:

- 18" (457 mm) high back
- Single high shelf
- Double high shelf

- 6" (152 mm) wide stainless steel plate shelf
- 8" (203 mm) wide stainless steel plate shelf

General:

- Casters — set of four 5" (127 mm) casters
- Flex Connector Kit [1"]:** NPT
 - 3" (914 mm)
 - 4" (1219 mm)
- Curb mounting:** Security Options/Prison Package [Consult Factory]

Oven:

- Cast iron oven bottom [136S Model only]
- Extra oven racks: ____ ea.

Manifolds: [Right rear with pressure regulator]:

- 1" NPT
- Manifold Cap: left side right side
- Stainless Manifold Cover: left side right side

INSTALLATION REQUIREMENTS & SHIPPING INFORMATION

- Ovens must be installed in accordance with local codes or in their absence with the National Fuel Gas Code: ANSI Z223.1; Natural Fuel Gas Code: CAN/CGA-B149.1 or Propane Installation Code: CAN/CGA-B149.2, as applicable. Compliance with codes is the responsibility of the Owner and Installer.
- An adequate ventilation system is required. Refer to National Fire Protection Association Standard No. 96, "Vapor Removal from Cooking Equipment."
- This appliance is intended for commercial use by professionally trained personnel. NOT intended for Residential Use.
- Specify installation elevation: _____ if above 2,000 ft (610m).
- GAS INLET SIZE (All Models):** 1-1/4 NPT front manifold with 1/2 union on each end provided for battery connection. A properly sized gas pressure regulator must be furnished by the Installer.
- The incoming gas line pressure into the regulator should be 8"-14" w.c. for natural gas, and 12"-14" w.c. for propane gas.

Minimum Clearances	Combustible Construction	Noncombustible Construction
From Back Wall*	2" (51 mm)	0"
Left & Right Side	6" (152 mm)	0"
With 6" (152 mm) legs	Suitable for installation on combustible floors	
*V136 models require 2" (51 mm) for motor clearance at rear		

Specify Type of Gas:		<input type="checkbox"/> Natural	<input type="checkbox"/> Propane	Shipping Weight	Shipping Class	Cube (Crated) ft ³ /m ³
Manifold Pressure:		6.0" WC	10.0" WC			
Models:	Burners	BTU/hr (kW)	BTU/hr (kW)			
136S	1	40,000 (11.8)	40,000 (11.8)	403 lbs (183 kg)	85	32/.9
V136S	1	45,000 (13.2)	45,000 (13.2)	478 lbs (217 kg)	85	32/.9
36S	0	n/a	n/a	478 lbs (217 kg)	85	32/.9
M36S	0	n/a	n/a	478 lbs (217 kg)	85	32/.9

Entry Clearance: 30" (762 mm) uncrated, with legs removed [All Models]

Due to continuous product improvements, specifications are subject to change without notice.



THE MONTAGUE COMPANY
1830 Stearman Avenue, Hayward, CA 94545
800 345-1830 • Fax: 510 785-3342
www.montaguecompany.com



HDS-33 [Rev. 01/10]