



LEGEND™ Heavy-Duty 36" (914mm) Gas Low-Boy Oven

Item No. _____

Project _____

Quantity _____

136LB or V136LB



Model 136LB shown with UFLC-36R

SHORT/BID SPECIFICATION

Oven shall be a Montague **Legend** Low-Boy Range-Base Model [Specify one]:

- 136LB**, with front vented 40,000 BTU/hr conventional oven with counterweighted door, porcelainized steel interior, three-position rack supports and one wire pan rack standard
- V136LB**, with indirect-fired 45,000 BTU/hr convection oven with counterweighted door, porcelainized steel interior, five-position adjustable nickel-plated rack supports and three wire pan racks standard

...a 36" (914mm) wide heavy duty gas-fired unit with stainless steel top; stainless steel front and exterior bottom, black painted sides and back, 1" (25mm) high flue riser and 3" (76mm) deep front rail standard; plus all the features listed and options/accessories checked:

STANDARD (136LB MODEL) OVEN FEATURES:

- 26" wide x 28" deep x 15" high (660 x 711 x 381mm) cooking compartment
- Accepts 18" x 26" (457 x 660mm) pans sideways or lengthwise
- Front venting oven design for more even cooking
- Heavy duty counterweighted oven door — no springs!
- Three position adjustable nickel-plated rack supports, with one rack standard
- Interior panels and door porcelain lined for long life & easy cleaning
- Low-to-500°F (260°C) thermostat mounted in insulated cool zone
- 40,000 BTU/hr cast iron burner with automatic ignition safety pilot

MODEL GUIDE

✓	Model No.	Base Style/Type	Top
	136LB	With Standard Oven	Stainless steel
	V136LB	With Convection Oven	Stainless steel

CONVECTION (V136LB MODEL) OVEN FEATURES:

- 26" wide x 22-1/4" deep x 15" high (660 x 565 x 381mm) cooking compartment
- Muffled, indirect fired design with blower, for fast-even cooking
- Heavy duty counterweighted oven door — no springs!
- Five position adjustable nickel-plated rack supports, with three racks standard
- Interior panels and door porcelain lined for long life & easy cleaning
- Low-to-500°F (260°C) thermostat mounted in insulated cool zone
- 45,000 BTU/hr cast iron burner with automatic ignition safety pilot
- 6' (1829mm) cord with 3-prong plug (grounding NEMA 5-15P)

STANDARD CONSTRUCTION FEATURES:

- Satin finish stainless steel front and exterior bottom
- Stainless steel top
- Other surfaces painted black with electrolytic zinc undercoating
- Stainless steel 1" (25mm) rear flue riser standard
- 6" stainless steel legs with adjustable bullet feet
- 3/4" NPT right-rear gas inlet & 3/4" NPT gas pressure regulator

AGENCY APPROVALS:

- NSF Listed
- ETL Design Certified to ANSI Z83.11 • CSA 1.8
- CE Approved • EN 203-1



HDS-50 [Rev. 1/12]

LEGEND™ Heavy-Duty 36" (914mm) Gas Low-Boy Oven

Item No. _____

Project _____

Quantity _____

136LB or V136LB

Dimensions in brackets are millimeters

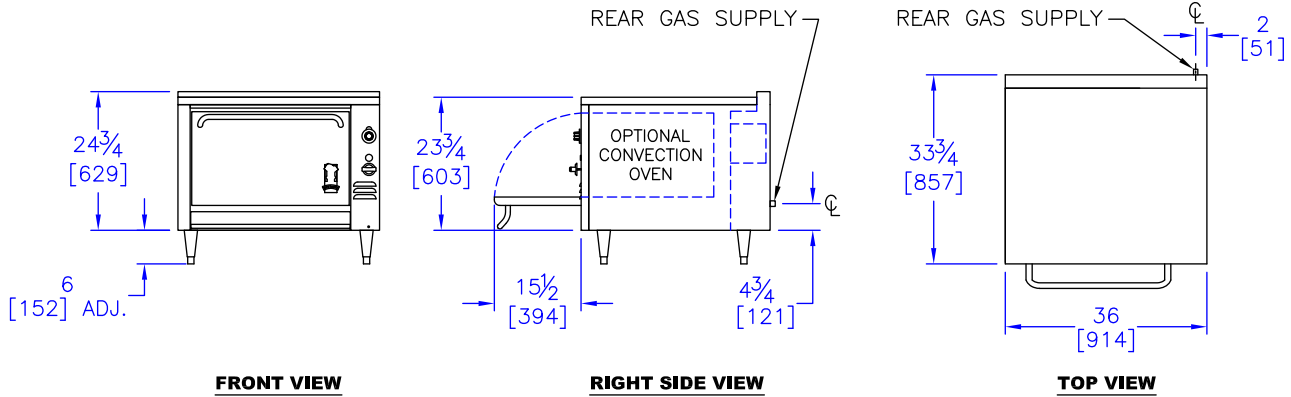

OPTIONS GUIDE:

Finish:

- Stainless steel left side panel
- Stainless steel right side panel
- Stainless steel back panel

Special Finish: [Consult factory]

Controls: [see Heavy Duty option page HDS-44]

- Electronic oven control (V136 & 136 ovens only)

Oven:

- Cast iron oven bottom [136LB Model only]
- Extra oven racks: _____ea.

Electrical (V136):

- 120 V, 1-phase, 60 Hz, 3.4 A (standard, with 6' (1.8m) NEMA 5-15P power cord)
- 208-240 V, 1-phase, 60 Hz, 1.7 A

General:

- Casters — set of four 5" (127 mm) casters
- Flanged feet with holes

Flex Connector Kit

[3/4"] or [1"] NPT

- 3' (910 mm)
- 4' (1219 mm)

Security Options/Prison Package

[Consult factory]

International Approvals:

- CE - Conformance Européenne - EN203-1
Includes flame failure valve option
- AGA - Australian Gas Association - AS 4563
Includes flame failure valve option
- Canadian Approval

INSTALLATION REQUIREMENTS & SHIPPING INFORMATION

- Ovens must be installed in accordance with local codes or in their absence with the National Fuel Gas Code: ANSI Z223.1; Natural Fuel Gas Code: CAN/CGA-B149.1 or Propane Installation Code: CAN/CGA-B149.2, as applicable. Compliance with codes is the responsibility of the Owner and Installer.
- An adequate ventilation system is required. Refer to National Fire Protection Association Standard No. 96, "Standard for Ventilation and Fire Protection of Commercial Cooking Operations."
- This appliance is intended for commercial use by professionally trained personnel. NOT intended for Residential Use.
- Specify installation elevation: _____ if above 2,000 ft (610m).
- GAS INLET SIZE (All Models): 3/4" NPT gas connection provided at right-rear. A 3/4" NPT gas pressure regulator is provided and must be installed (by others) when unit is connected to gas supply.
- The incoming gas line pressure into the regulator should be 8"-14" w.c. for natural gas, and 12"-14" w.c. for propane gas.

Minimum Clearances	Combustible Construction	Noncombustible Construction
From Back Wall*	2" (51mm)	0"
Left & Right Side	6" (152mm)*	0"
With 6" (152mm) legs	Suitable for installation on combustible floors	
*V136 models require 2" (51mm) for motor clearance at rear		

Models	Burners	Specify Type of Gas:		Electrical	Shipping Weight	Shipping Class	Cube (Crated) ft ³ /m ³
		<input type="checkbox"/> Natural	<input type="checkbox"/> Propane				
		Manifold Pressure:	6.0" WC	10.0" WC	120V		
			BTU/hr (kW)	BTU/hr (kW)	Amperage		
136LB	1		40,000 (11.8)	40,000 (11.8)	---	403 lbs (183 kg)	85
V136LB	1		45,000 (13.2)	45,000 (13.2)	3.4	478 lbs (217 kg)	85

Entry Clearance: 30" (762mm) uncrated, with legs removed [All Models]



THE MONTAGUE COMPANY

1830 Stearman Avenue, Hayward, CA 94545
 800 345-1830 • Fax: 510 785-3342

www.montaguecompany.com

Due to continuous product improvements, specifications are subject to change without notice.



HDS-50 [Rev. 1/12]