



LEGEND™ Heavy-Duty 36" (914mm) Gas Range

Item No. _____

Project _____

Quantity _____

(-9E) Top Series



Model 136-9E

SHORT/BID SPECIFICATION

Range shall be a Montague **Legend** Model [Specify one]:

- 136-9E**, with front-vented 40,000 BTU/hr conventional oven with counterweighted door, porcelainized steel interior, three-position rack guides and one wire pan rack standard
- V136-9E**, with indirect-fired 45,000 BTU/hr convection oven with counterweighted door, porcelainized steel interior, five-position rack guides and three wire pan racks standard
- 36-9E**, with open front cabinet base with two shelves;
- M36-9E**, with 28" (711mm) high modular stand with stainless steel tubular legs;

...a 36" (914mm) wide heavy-duty gas-fired unit with three Even-Heat 20,000 BTU/hr 12" (305mm) wide solid hot tops with one-piece cast iron plate, provided with individual burner controls and automatic standing pilots; with stainless steel front and exterior bottom, black painted sides and back, 4" (102mm) high flue riser and 3" (76mm) deep front rail standard; plus all the features listed and options/accessories checked:

RANGE TOP FEATURES:

Three 12" wide x 31" deep (305 x 787mm) Hot Tops with:

- Heavy-duty cast iron precision-ground plates
- Cast iron EVEN HEAT 20,000 BTU/hr burners
- Heat transfer studs cast in plate bottoms
- 2" (51mm) side and front flanges isolate heat under plates
- Insulating partition between top sections

MODEL GUIDE			
✓	Model No.	Base Style/Type	-9E Range Top
	136-9E	With Standard Oven	
	V136-9E	With Convection Oven	
	36-9E	With Cabinet Base	
	M36-9E	With Modular Stand	

STANDARD (136-9E MODEL) OVEN FEATURES:

- 26" wide x 22-1/4" deep x 15" high (660 x 711 x 381mm) cooking compartment
- Accepts 18" x 26" (457 x 660mm) pans sideways or lengthwise
- Front-venting oven design for more even cooking
- Heavy-duty counterweighted oven door — no springs
- Three-position adjustable nickel-plated rack supports, with one rack standard
- Interior panels and door porcelain lined for long life & easy cleaning
- Low-to-500°F (260°C) thermostat mounted in insulated cool zone
- 40,000 BTU/hr cast iron burner with automatic ignition safety pilot

CONVECTION (V136-9E MODEL) OVEN FEATURES:

- 26" wide x 22-1/4" deep x 15" high (660 x 565 x 381mm) cooking compartment
- Muffled, indirect-fired design with blower, for fast, even cooking
- Heavy-duty counterweighted oven door — no springs
- Five-position adjustable nickel-plated rack supports, with three racks standard
- Interior panels and door porcelain lined for long life & easy cleaning
- Low-to-500°F (260°C) thermostat mounted in insulated cool zone
- 45,000 BTU/hr cast iron burner with automatic ignition safety pilot
- 6' (1829mm) cord with 3-prong plug (grounding NEMA 5-15P)

STANDARD CONSTRUCTION FEATURES:

- Satin finish stainless steel front and exterior bottom with 3" (76mm) deep front rail
- Other surfaces painted black with electrolytic zinc undercoating
- Stainless steel 4" (102mm) rear flue riser standard
- 6" (152mm) adjustable stainless steel legs standard (Except M36-9E Model)
- 28" (711mm) stainless steel tubular legs standard with M36-9E Model
- Cabinet base with sides, back panel and two shelves on 36-9E Model
- 1-1/4" NPT front gas manifold with 1/2 union on each end

AGENCY APPROVALS:

- NSF Listed
- ETL Design Certified to ANSI Z83.11 • CSA 1.8
- CE Approved • EN 203-1



HDS-24 [Rev. 1/12]

Item No. _____

Project _____

Quantity _____

LEGEND™ Heavy-Duty 36" (914mm) Gas Range

(-9E) Top Series

Dimensions in brackets are millimeters

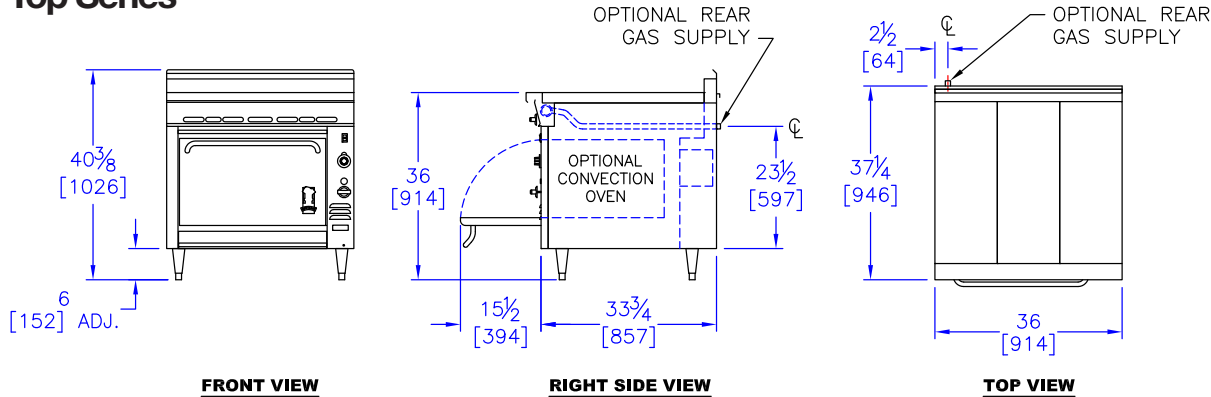

OPTIONS GUIDE:

Top Range:

- 42" (1067mm) range depth [Add Suffix: -40]

Oven:

- Cast iron oven bottom
- Extra oven racks: ____ea.
- 650°F (343°C) finishing oven with cast iron oven bottom-*includes cast iron oven bottom option* [see Heavy Duty option page HDS-46]

Back Panels/Shelves:

- 18" (457mm) high back
- Single high shelf
- Double high shelf
- 6" (152mm) wide stainless steel plate shelf
- 8" (203mm) wide stainless steel plate shelf

Finish:

- Stainless steel left side panel
- Stainless steel right side panel
- Stainless steel back panel
- Stainless steel shelves and sides [36-9E Cabinet Model]

Special Finish: [Consult Factory]

Manifolds: [Left rear with pressure regulator]:

- 1" NPT up to 400,000 BTU/hr
- Manifold Cap:** left side right side
- Stainless Manifold Cover:** left side right side

Electrical (V136):

- 120 V, 1-phase, 60 Hz, 3.4 A (standard, with 6' (1.8m) NEMA 5-15P power cord)
- 208-240 V, 1-phase, 60 Hz, 1.7 A

Controls: [see Heavy Duty option page HDS-46]

- Electronic rangetop pilot ignition; electronic oven control (V136 & 136 ovens only)
- Flame failure rangetop safety valves
- Electronic rangetop pilot ignition & flame failure rangetop safety valves; electronic oven control (V136 & 136 ovens only)

General:

- Casters — set of four 5" (127mm) casters
- Flanged feet with holes

Flex Connector Kit [1"] NPT:

- 3' (914mm) 4' (1219mm)

Security Options/Prison Package

[Consult Factory]

International Approvals:

- CE - Conformance Européenne - EN203-1
- Includes flame failure valve option*
- Canadian Approval

INSTALLATION REQUIREMENTS & SHIPPING INFORMATION

1. Ovens & ranges must be installed in accordance with local codes or in their absence with the National Fuel Gas Code: ANSI Z223.1; Natural Fuel Gas Code: CAN/CGA-B149.1 or Propane Installation Code: CAN/CGA-B149.2, as applicable. Compliance with codes is the responsibility of the Owner and Installer.
2. An adequate ventilation system is required. Refer to National Fire Protection Association Standard No. 96, "Vapor Removal from Cooking Equipment."
3. This appliance is intended for commercial use by professionally trained personnel. NOT intended for Residential Use.
4. Specify installation elevation: _____ if above 2,000 ft (610m).
5. GAS INLET SIZE (All Models): 1-1/4 NPT front manifold with 1/2 union on each end provided for battery connection. A properly sized gas pressure regulator must be furnished by the Installer.
6. The incoming gas line pressure into the regulator should be 8"-14" w.c. for natural gas, and 12"-14" w.c. for propane gas.

Minimum Clearances	Combustible Construction	Noncombustible Construction
From Back Wall*	2" (51mm)	0"
Left & Right Side	6" (152mm)	0"
With 6" (152mm) legs	Suitable for installation on combustible floors	
*V136-9E Model requires 2" (51mm) for motor clearance at rear		

Specify Type of Gas:		<input type="checkbox"/> Natural	<input type="checkbox"/> Propane	Electrical	Shipping Weight	Shipping Class	Cube (Crated) ft ³ /m ³
Gas Delivery Pressure:		6.0" WC	10.0" WC	120V			
Models:	Burners	BTU/hr (kW)	BTU/hr (kW)	Amperage			
136-9E	4	100,000 (29.3)	100,000 (29.3)	---	568 lbs (257 kg)	85	27/.75
V136-9E	4	105,000 (30.8)	105,000 (30.8)	3.4	580 lbs (263 kg)	85	27/.75
36-9E	3	60,000 (17.6)	60,000 (17.6)	---	420 lbs (190 kg)	85	27/.75
M36-9E	3	60,000 (17.6)	60,000 (17.6)	---	395 lbs (179 kg)	85	13/.4

Entry Clearance: 30" (762mm) uncrated, with legs removed [All Models]

Due to continuous product improvements, specifications are subject to change without notice.



THE MONTAGUE COMPANY
 1830 Stearman Avenue, Hayward, CA 94545
 800 345-1830 • Fax: 510 785-3342
 www.montaguecompany.com



HDS-24 [Rev. 1/12]