



LEGEND™

Heavy-Duty 36" (914mm) Gas Range

Item No. _____

Project _____

Quantity _____

(-7) Top Series



Model M36-7

SHORT/BID SPECIFICATION

Range shall be a Montague *Legend* Model [Specify one]:

- 136-7**, with front-vented 40,000 BTU/hr conventional oven with counterweighted door, porcelainized steel interior, three-position rack guides and one wire pan rack standard
- V136-7**, with indirect-fired 45,000 BTU/hr convection oven with counterweighted door, porcelainized steel interior, five-position rack guides and three wire pan racks standard
- 36-7**, with open front cabinet base with two shelves;
- M36-7**, with 28" (711mm) high modular stand with stainless steel tubular legs;

...a 36" (914mm) wide heavy-duty gas-fired unit with a 24" (610mm) wide griddle with 3/4" (19mm) thick precision-ground cook surface, 2" (102mm) high tapered splash next to open burners, 2-5/8" (67mm) wide front grease trough with drop to grease receptacle and three 15,000 BTU/hr burners; plus one 12" (305mm) heavy-duty cast iron, precision-ground open top grate, over two 30,000 BTU/hr lift off star burners, provided with individual burner controls and automatic standing pilots; with stainless steel front and exterior bottom, black painted sides, 4" (102mm) high flue riser and 3" (76mm) deep front rail standard; plus all the features listed and options/accessories checked:

RANGE TOP FEATURES:

One 24" wide x 28" deep (610mm x 711mm) griddle, positioned left, with:

- 3/4" (19mm) thick precision-ground steel cook surface
- 2" (51mm) high backsplash and tapered side-splashes
- 2-5/8" (67mm) wide grease trough pitched to grease receptacle
- Built-in 2-1/8" (54mm) hanging grease receptacle
- Three 15,000 BTU/hr gas burners with standing pilots & gas control valves
- Adjusting bolts for changing griddle forward pitch

MODEL GUIDE		
✓ Model No.	Base Style/Type	-7 Range Top
136-7	With Standard Oven	
V136-7	With Convection Oven	
36-7	With Cabinet Base	
M36-7	With Modular Stand	

One 12" wide x 31" deep (305mm x 787mm) open burner top, positioned right, with:

- Heavily ribbed cast iron, surface-ground top grates
- Two large diameter 30,000 BTU/hr lift off star burners with raised ports
- Automatic, standing pilots
- Drip pan positioned under burners

STANDARD (136-7 MODEL) OVEN FEATURES:

- 26" wide x 28" deep x 15 high (660mm x 711mm x 381mm) cooking compartment
- Accepts 18" x 26" (457mm x 660mm) pans sideways or lengthwise
- Front-venting oven design for more even cooking
- Heavy-duty counterweighted oven door — no springs
- Three-position adjustable nickel-plated rack supports, with one rack standard
- Interior panels and door porcelain lined for long life & easy cleaning
- Low-to-500°F (260°C) thermostat mounted in insulated cool zone
- 40,000 BTU/hr cast iron burner with automatic ignition safety pilot

CONVECTION (V136-7 MODEL) OVEN FEATURES:

- 26" wide x 22-1/4" deep x 15" high (660mm x 565mm x 381mm) cooking compartment
- Muffled, indirect fired design with blower, for fast-even cooking
- Heavy-duty counterweighted oven door — no springs
- Five-position adjustable nickel-plated rack supports, with three racks standard
- Interior panels and door porcelain lined for long life & easy cleaning
- Low-to-500°F (260°C) thermostat mounted in insulated cool zone
- 45,000 BTU/hr cast iron burner with automatic ignition safety pilot

STANDARD CONSTRUCTION FEATURES:

- Satin finish stainless steel front with 3" (76mm) deep front rail
- Other surfaces painted black with electrolytic zinc undercoating
- Stainless steel 4" (102mm) rear flue riser standard
- 6" (152mm) adjustable stainless steel legs standard (Except M36-7 Model)
- 28" (711mm) stainless steel tubular legs standard with M36-7 Model
- Cabinet base with sides, back panel and two shelves on 36-7 Model
- 1-1/4" NPT front gas manifold with 1/2 union on each end

STANDARD WARRANTY:

- One Year, Parts & Labor
- Lifetime Warranty on Oven Door

AGENCY APPROVALS

- NSF Listed
- ETL Design Certified to ANSI Z83.11



HDS-13 [Rev. 01/10]

Item No. _____

Project _____

Quantity _____

LEGEND™ Heavy-Duty 36" (914mm) Gas Range

(-7) Top Series

Dimensions in brackets are millimeters

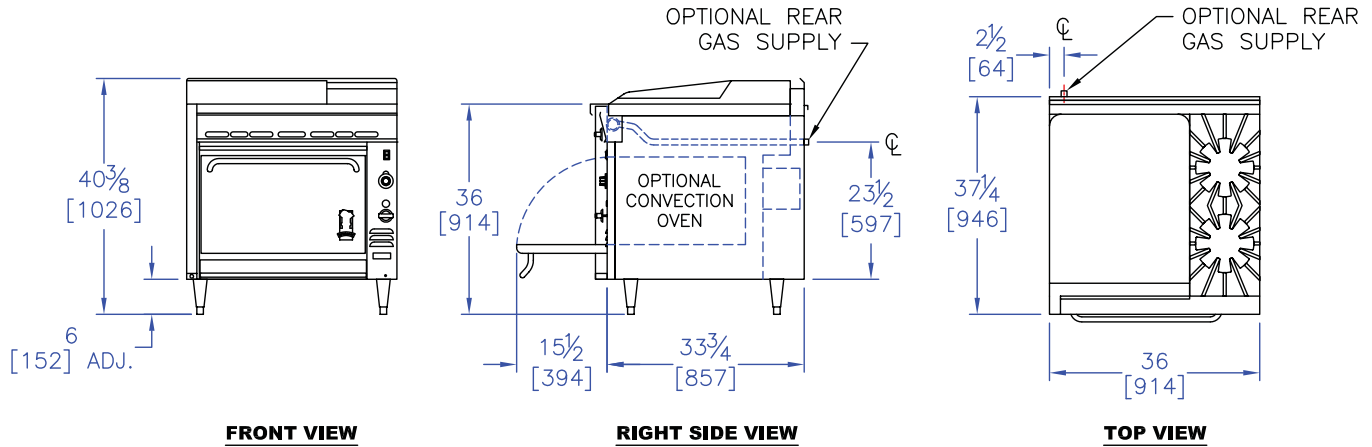

OPTIONS GUIDE:

Open Burner Top Section:

- 30,000 BTU/hr lift off star burner with raised ports with 15,000 BTU/hr rear solid hot top [-59]
- Cast Iron Ribbon Grate, (for use with 20,000 BTU/hr burners only)
- 20,000 BTU/hr lift off star burner (2)
- 42" (1067mm) range depth [Add Suffix: -40]
- 304 stainless steel burner box assembly

Back Panels/Shelves:

- 18" (457mm) high back
- Single high shelf
- Double high shelf
- 6" (152mm) wide stainless steel plate shelf
- 8" (203mm) wide stainless steel plate shelf

24" Griddle/Fry Top:

- 450°F (232°C) Thermostatic Control [-T Suffix]
- 1" (25mm) thick griddle plate
- 1" (25mm) thick grooved griddle plate
- 34" (864mm) range depth [Add Suffix -40]

Oven:

- Cast iron oven bottom
- Extra oven racks: _____ ea.

Manifolds: [Left rear with pressure regulator]:

- 1" NPT up to 400,000 BTU/hr
- Manifold Cap:** left side right side
- Stainless Manifold Cover:** left side right side

Finish:

- Stainless steel left side panel
- Stainless steel right side panel
- Stainless steel back panel
- Stainless steel exterior bottom
- Stainless steel shelves and sides [36-7 Cabinet Model]

General:

- Casters — set of four 5" (127mm) casters
- Flex Connector Kit** [1"/25 mm]: 3' (914mm) 4' (1219mm)
- Security Options/Prison Package** [Consult Factory]

INSTALLATION REQUIREMENTS & SHIPPING INFORMATION

- Ovens & ranges must be installed in accordance with local codes or in their absence with the National Fuel Gas Code: ANSI Z223.1; Natural Fuel Gas Code: CAN/CGA-B149.1 or Propane Installation Code: CAN/CGA-B149.2, as applicable. Compliance with codes is the responsibility of the Owner and Installer.
- An adequate ventilation system is required. Refer to National Fire Protection Association Standard No. 96, "Vapor Removal from Cooking Equipment."
- This appliance is intended for commercial use by professionally trained personnel. NOT intended for Residential Use.
- Specify installation elevation: _____ if above 2,000 ft (610m).
- GAS INLET SIZE (All Models):** 1-1/4 NPT front manifold with 1/2 union on each end provided for battery connection. A properly sized gas pressure regulator must be furnished by the Installer.
- The incoming gas line pressure into the regulator should be 8"-14" w.c. for natural gas, and 12"-14" w.c. for propane gas.

Minimum Clearances	Combustible Construction	Noncombustible Construction
From Back Wall*	2" (51mm)	0"
Left & Right Side**	15" (381mm)	0"
With 6" (152mm) legs	Suitable for installation on combustible floors	
*V136 Models require 2" (51 mm) for motor clearance at rear		

Specify Type of Gas:		<input type="checkbox"/> Natural	<input type="checkbox"/> Propane	Shipping Weight	Shipping Class	Cube (Crated) ft ³ /m ³
Gas Delivery Pressure:		6.0" WC	10.0" WC			
Models:	Burners	BTU/hr* (kW)	BTU/hr* (kW)			
136-7	6	145,000 (42.5)	145,000 (42.5)	636 lbs (288 kg)	85	32/.9
V136-7	6	150,000 (44.0)	150,000 (44.0)	660 lbs (299 kg)	85	32/.9
36-7	5	105,000 (30.8)	105,000 (30.8)	450 lbs (204 kg)	85	32/.9
M36-7	5	105,000 (30.8)	105,000 (30.8)	390 lbs (177 kg)	85	18/.5

For thermostatically controlled fry top add 15,000 BTU/hr (4.4 kW).

Entry Clearance: 30" (762mm) uncrated, with legs removed [All Models]

Due to continuous product improvements, specifications are subject to change without notice.



THE MONTAGUE COMPANY
 1830 Stearman Avenue, Hayward, CA 94545
 800 345-1830 • Fax: 510 785-3342
 www.montaguecompany.com



HDS-13 [Rev. 01/10]