



# LEGEND™ Heavy-Duty 36" (914 mm) Gas Range

Item No. \_\_\_\_\_

Project \_\_\_\_\_

Quantity \_\_\_\_\_

## (-559) Top Series



Model 136-559

### SHORT/BID SPECIFICATION

Range shall be a Montague **Legend** Model [Specify one]:

- 136-559**, with front-vented 40,000 BTU/hr conventional oven with counterweighted door, porcelainized steel interior, three-position rack guides and one wire pan rack standard
- V136-559**, with indirect-fired 45,000 BTU/hr convection oven with counterweighted door, porcelainized steel interior, five-position rack guides and three wire pan racks standard
- 36-559**, with open front cabinet base with two shelves;
- M36-559**, with 28" (711 mm) high modular stand with stainless steel tubular legs;

...a 36" (914 mm) wide heavy-duty gas-fired unit with a three 12" (305 mm) combination open burner/hot tops, with front heavy-duty cast iron, precision ground open top grate, over a 30,000 BTU/hr lift off star burner and rear 15,000 BTU/hr solid cast iron hot top, provided with individual burner controls and automatic standing pilots; with stainless steel front and exterior bottom, black painted sides and back, 4" (102 mm) high flue riser and 3" (76 mm) deep front rail standard; plus all the features listed and options/accessories checked:

### RANGE TOP FEATURES:

Three 12" wide x 15-1/2" deep (305 mm x 394 mm) combination open/hot burner tops, with:

- Heavily ribbed cast iron, surface-ground top grates
- Large diameter 30,000 BTU/hr lift off star burners with raised ports in front
- Automatic, standing pilots
- Drip pans positioned under star burners
- Solid hot top in back with 15,000 BTU/hr burner

### MODEL GUIDE

✓ Model No.	Base Style/Type	-559 Range Top
136-559	With Standard Oven	
V136-559	With Convection Oven	
36-559	With Cabinet Base	
M36-559	With Modular Stand	

### STANDARD (136-559 MODEL) OVEN FEATURES:

- 26" wide x 28" deep x 15" high (660 mm x 711 mm x 381 mm) cooking compartment
- Accepts 18" x 26" (457 mm x 26 mm) pans sideways or lengthwise
- Front venting oven design for more even cooking
- Heavy duty counterweighted oven door — no springs
- Three position adjustable nickel-plated rack supports, with one rack standard
- Interior panels and door porcelain-lined for long life & easy cleaning
- Low-to-500°F (260°C) thermostat mounted in insulated cool zone
- 40,000 BTU/hr cast iron burner with automatic ignition safety pilot

### CONVECTION (V136-559 MODEL) OVEN FEATURES:

- 26" wide x 22-1/4" deep x 15" high (660 mm x 565 mm x 381mm) cooking compartment
- Muffled, indirect fired design with blower, for fast, even cooking
- Heavy duty counterweighted oven door — no springs
- Five position adjustable nickel-plated rack supports, with three racks standard
- Interior panels and door porcelain lined for long life & easy cleaning
- Low-to-500°F (260°C) thermostat mounted in insulated cool zone
- 45,000 BTU/hr cast iron burner with automatic ignition safety pilot

### STANDARD CONSTRUCTION FEATURES:

- Satin finish stainless steel front with 3" (76 mm) deep front rail
- Other surfaces painted black with electrolytic zinc undercoating
- Stainless steel 4" (102 mm) rear flue riser standard
- 6" (152 mm) adjustable stainless steel legs standard (Except M36-559 Model)
- 28" (711 mm) stainless steel tubular legs standard with M36-559 Model
- Cabinet base with sides, back panel and two shelves on 36-559 Model
- 1-1/4" NPT front gas manifold with 1/2 union on each end

### STANDARD WARRANTY:

- One Year, Parts & Labor
- Lifetime Warranty on Oven Door

### AGENCY APPROVALS

- NSF Listed
- ETL Design Certified to ANSI Z83.11



HDS-9 [Rev. 01/10]

Item No. \_\_\_\_\_

Project \_\_\_\_\_

Quantity \_\_\_\_\_

# LEGEND™ Heavy-Duty 36" (914 mm) Gas Range

## (-559) Top Series

Dimensions in brackets are millimeters

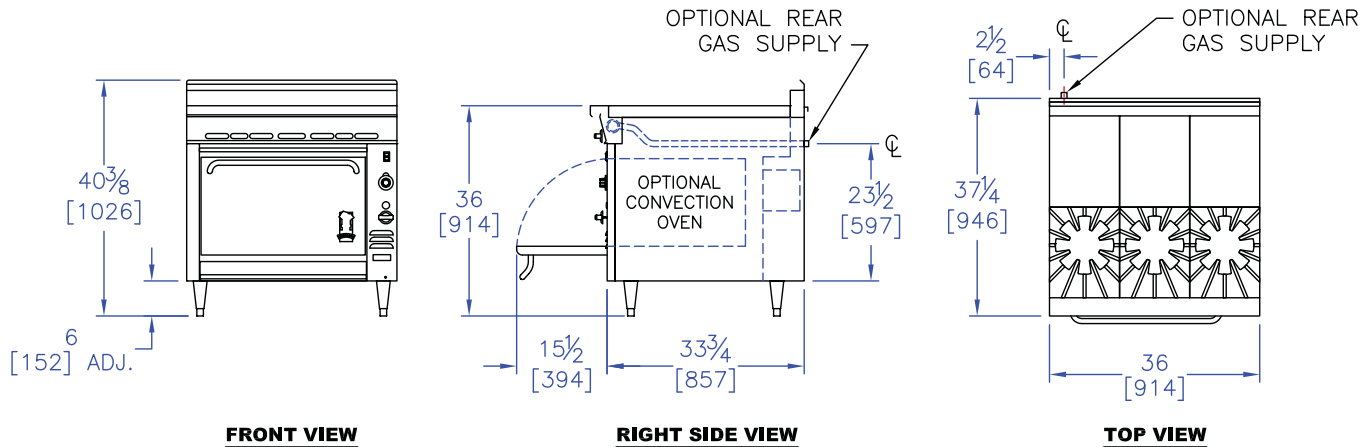

### OPTIONS GUIDE:

#### Open Burners Top Section:

- 42" (1067 mm) range depth [Add Suffix: -40]
- 304 stainless steel burner box assembly

#### Back Panels/Shelves:

- 18" (457 mm) high back
- Single high shelf
- Double high shelf
- 6" (152 mm) wide stainless steel plate shelf
- 8" (203 mm) wide stainless steel plate shelf

#### Oven:

- Cast iron oven bottom
- Extra oven racks: \_\_\_\_\_ea.

#### Manifolds: [Left rear with pressure regulator]:

- 1" NPT up to 400,000 BTU/hr
- Manifold Cap:**  left side  right side
- Stainless Manifold Cover:**  left side  right side

#### Finish:

- Stainless steel left side panel
- Stainless steel right side panel
- Stainless steel back panel
- Stainless steel exterior bottom
- Stainless steel shelves and sides [36-559 Cabinet Model]

#### General:

- Casters — set of four 5" (127 mm) casters
- Flex Connector Kit**  [1"] NPT:  3' (914 mm)  4' (1219 mm)
- Security Options/Prison Package** [Consult Factory]

### INSTALLATION REQUIREMENTS & SHIPPING INFORMATION

1. Ovens & ranges must be installed in accordance with local codes or in their absence with the National Fuel Gas Code: ANSI Z223.1; Natural Fuel Gas Code: CAN/CGA-B149.1 or Propane Installation Code: CAN/CGA-B149.2, as applicable. Compliance with codes is the responsibility of the Owner and Installer.
2. An adequate ventilation system is required. Refer to National Fire Protection Association Standard No. 96, "Vapor Removal from Cooking Equipment."
3. This appliance is intended for commercial use by professionally trained personnel. NOT intended for Residential Use.
4. Specify installation elevation: \_\_\_\_\_ if above 2,000 ft (610m).
5. GAS INLET SIZE (All Models): 1-1/4 (32mm) front manifold with 1/2 union on each end provided for battery connection. A properly sized gas pressure regulator must be furnished by the Installer.
6. The incoming gas line pressure into the regulator should be 8"-14" w.c. for natural gas, and 12"-14" w.c. for propane gas.

Minimum Clearances	Combustible Construction	Noncombustible Construction
From Back Wall*	2" (51 mm)	0"
Left & Right Side**	15" (381 mm)	0"
With 6" (152 mm) legs	Suitable for installation on combustible floors	
*V136 Models require 2" (51 mm) for motor clearance at rear		

Specify Type of Gas:		<input type="checkbox"/> Natural	<input type="checkbox"/> Propane	Shipping Weight	Shipping Class	Cube (Crated) ft <sup>3</sup> /m <sup>3</sup>
Gas Delivery Pressure:		6.0" WC	10.0" WC			
Models:	Burners	BTU/hr* (kW)	BTU/hr* (kW)			
136-559	7	175,000 (51.3)	175,000 (51.3)	560 lbs (254 kg)	85	32/.9
V136-559	7	180,000 (52.8)	180,000 (52.8)	580 lbs (263 kg)	85	32/.9
36-559	6	135,000 (39.6)	135,000 (39.6)	385 lbs (175 kg)	85	27/.75
M36-559	6	135,000 (39.6)	135,000 (39.6)	322 lbs (146 kg)	85	18/.5

Entry Clearance: 30" (762 mm) uncrated, with legs removed [All Models]

Due to continuous product improvements, specifications are subject to change without notice.



**THE MONTAGUE COMPANY**  
 1830 Stearman Avenue, Hayward, CA 94545  
 800 345-1830 • Fax: 510 785-3342  
 www.montaguecompany.com



HDS-9 [Rev. 01/10]