



**LEGEND™**

**Heavy-Duty 36" (914 mm) Gas Range**

Item No. \_\_\_\_\_

Project \_\_\_\_\_

Quantity \_\_\_\_\_

**(-1E) Top Series**



Model 136-1E

**SHORT/BID SPECIFICATION**

Range shall be a Montague **Legend** Model [Specify one]:

- 136-1E**, with front-vented 40,000 BTU/hr conventional oven with counterweighted door, porcelainized steel interior, three-position rack guides and one wire pan rack standard
- V136-1E**, with indirect-fired 45,000 BTU/hr convection oven with counterweighted door, porcelainized steel interior, five-position rack guides and three wire pan racks standard
- V36-1E**, with open front cabinet base with two shelves;
- M36-1E**, with 28" (711 mm) high modular stand with stainless steel tubular legs;

... a 36" (914 mm) wide heavy-duty gas-fired unit with a 12" (305 mm) wide griddle with 3/4" (19 mm) thick precision-ground cook surface, 2" (51 mm) high splash, 2-5/8" (67 mm) wide front grease trough with drop to grease receptacle and one 15,000 BTU/hr burner; plus two Even-Heat 20,000 BTU/hr 12" (305 mm) wide solid hot tops with one-piece cast iron plate, provided with individual burner controls and automatic standing pilots; with stainless steel front and exterior bottom, black painted sides and back, 4" (102 mm) high flue riser and 3" (76 mm) deep front rail standard; plus all the features listed and options/accessories checked:

**RANGE TOP FEATURES:**

**One 12" wide x 28" (305 mm x 711 mm) deep griddle, positioned left, with**

- 3/4" (19 mm) thick precision-ground steel cook surface
- 2" (102 mm) high backsplash and tapered side-splashes
- 2-5/8" (67 mm) front grease trough pitched to grease receptacle
- Built-in 2-1/8" (54 mm) hanging grease receptacle
- One 15,000 BTU/hr gas burner with standing pilot & gas control valve
- Adjusting bolts for changing griddle forward pitch

MODEL GUIDE		
Model No.	Base Style/Type	-1E Range Top
136-1E	With Standard Oven	
V136-1E	With Convection Oven	
36-1E	With Cabinet Base	
M36-1E	With Modular Stand	

**Two 12" wide x 31" deep (305 mm x 787 mm) Hot Tops positioned right, with:**

- Heavy cast iron precision-ground plate
- Cast iron EVEN HEAT 20,000 BTU/hr burners
- Heat transfer studs cast in plate bottom
- 2" (51 mm) side and front flanges to isolate heat under plate
- Insulating partition between top sections

**STANDARD (136-1E MODEL) OVEN FEATURES:**

- 26" wide x 28" deep x 15" high (660 mm x 711 mm x 381 mm) cooking compartment
- Accepts 18" x 26" (457 mm x 660 mm) pans sideways or lengthwise
- Front-venting oven design for more even cooking
- Heavy-duty counterweighted oven door - no springs
- Three position adjustable nickel-plated rack supports with one rack standard
- Interior panels and door porcelain-lined for long life & easy cleaning
- Low-to-500°F (260°C) thermostat mounted in insulated cool zone
- 40,000 BTU/hr cast iron burner with automatic ignition safety pilot

**CONVECTION (V136-1E MODEL) OVEN FEATURES:**

- 26" wide x 22-1/4" deep x 15" high (660 mm x 565 mm x 381 mm) cooking compartment
- Muffled, indirect fired design with blower, for fast-even cooking
- Heavy-duty counterweighted oven door - no springs
- Five-position adjustable nickel-plated rack supports with three racks standard
- Interior panels and door porcelain-lined for long life & easy cleaning
- Low-to-500°F (260°C) thermostat mounted in insulated cool zone
- 45,000 BTU/hr cast iron burner with automatic ignition safety pilot

**STANDARD CONSTRUCTION FEATURES:**

- Satin finish stainless steel front with 3" (76 mm) deep front rail
- Other surfaces painted black with electrolytic zinc undercoating
- Stainless steel 4" (102 mm) rear flue riser standard
- 6" (152 mm) adjustable stainless steel legs standard (Except M36-1E Model)
- 28" (711 mm) stainless steel tubular legs standard with M36-1E Model
- Cabinet base with sides, back panel and two shelves on 36-1E Model
- 1-1/4" NPT front gas manifold with 1/2 union on each end

**STANDARD WARRANTY:**

- One Year, Parts & Labor
- Lifetime Warranty on Oven Door

**AGENCY APPROVALS**

- NSF Listed
- ETL Design Certified to ANSI Z83.11



HDS-3 [Rev. 01/10]

Item No. \_\_\_\_\_

Project \_\_\_\_\_

Quantity \_\_\_\_\_

# LEGEND™ Heavy-Duty 36" (914 mm) Gas Range

## (-1E) Top Series

Dimensions in brackets are millimeters

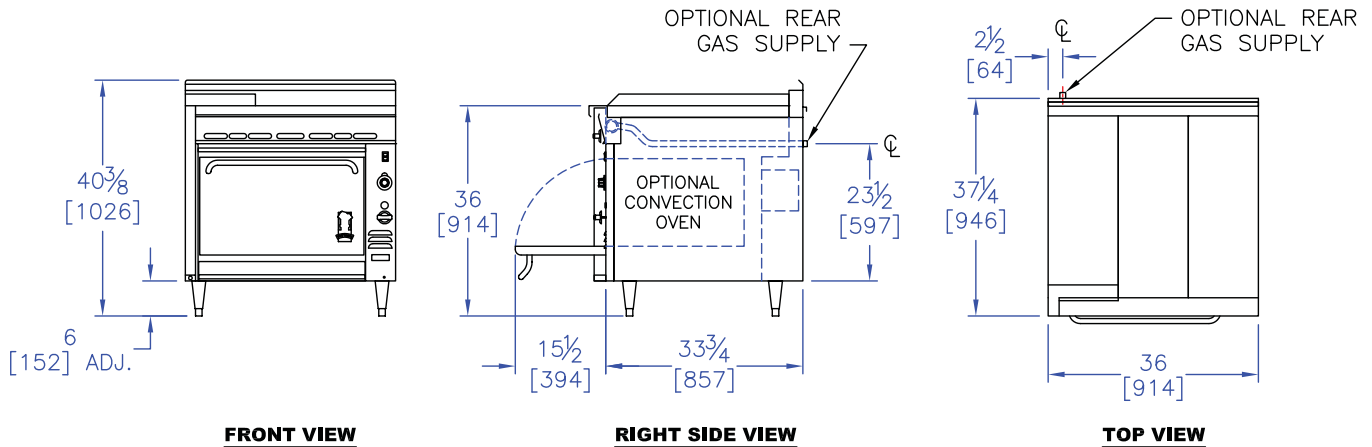

### OPTIONS GUIDE:

#### 12" (305mm) Griddle:

- 450° Thermostatic Control
- 550° Thermostatic Control
- 1" (25 mm) thick griddle plate
- 1" (25 mm) thick grooved griddle plate
- 34" (864 mm) deep plate [Add Suffix -40]
- 42" (1067 mm) range depth [Add Suffix: -40]

#### Back Panels/Shelves:

- 18" (457 mm) high back
- Single high shelf
- Double high shelf
- 6" (152 mm) wide stainless steel plate shelf
- 8" (203 mm) wide stainless steel plate shelf

#### Oven:

- Cast iron oven bottom
- Extra oven racks: \_\_\_\_\_ea.

#### Manifolds: [Left rear with pressure regulator]:

- 1" NPT up to 400,000 BTU/hr

#### Manifold Cap:

- left side  right side

#### Stainless Manifold Cover:

- left side  right side

#### Finish:

- Stainless steel left side panel
- Stainless steel right side panel
- Stainless steel back panel
- Stainless steel exterior bottom
- Stainless steel shelves and sides [36-1E Cabinet Model]

#### General:

- Casters — set of four 5" (127 mm) casters

#### Flex Connector Kit [1"] NPT:

- 3' (914 mm)  4' (1219 mm)

#### Security Options/Prison Package

[Consult Factory]

### INSTALLATION REQUIREMENTS & SHIPPING INFORMATION

1. Ovens & ranges must be installed in accordance with local codes or in their absence with the National Fuel Gas Code: ANSI Z223.1; Natural Fuel Gas Code: CAN/CGA-B149.1 or Propane Installation Code: CAN/CGA-B149.2, as applicable. Compliance with codes is the responsibility of the Owner and Installer.
2. An adequate ventilation system is required. Refer to National Fire Protection Association Standard No. 96, "Vapor Removal from Cooking Equipment."
3. This appliance is intended for commercial use by professionally trained personnel. NOT intended for Residential Use.
4. Specify installation elevation: \_\_\_\_\_ if above 2,000 ft (610m).
5. GAS INLET SIZE (All Models): 1-1/4 (32mm) front manifold with 1/2 union on each end provided for battery connection. A properly sized gas pressure regulator must be furnished by the Installer.
6. The incoming gas line pressure into the regulator should be 8"-14" w.c. for natural gas, and 12"-14" w.c. for propane gas.

Minimum Clearances	Combustible Construction	Noncombustible Construction
From Back Wall*	2" (51 mm)	0"
Left & Right Side	6" (152 mm)	0"
With 6" (152 mm) legs	Suitable for installation on combustible floors	
*V136 models require 2" (51 mm) for motor clearance at rear		

Models:	Burners	Specify Type of Gas:		Shipping Weight	Shipping Class	Cube (Crated) ft <sup>3</sup> /m <sup>3</sup>
		<input type="checkbox"/> Natural	<input type="checkbox"/> Propane			
Gas Delivery Pressure:		6.0" WC	10.0" WC			
		BTU/hr* (kW)	BTU/hr* (kW)			
136-1E	4	95,000 (27.8)	95,000 (27.8)	670 lbs (304 kg)	85	32/.9
V136-1E	4	100,000 (29.3)	100,000 (29.3)	700 lbs (317 kg)	85	32/.9
36-1E	3	55,000 (16.1)	55,000 (16.1)	440 lbs (199 kg)	85	32/.9
M36-1E	3	55,000 (16.1)	55,000 (16.1)	370 lbs (168 kg)	85	18/.5

\*Add 5,000 BTU/hr (1.5 kW) for 42" (1067 mm) deep Griddle Top [-40] and thermostatically controlled griddle.

Entry Clearance: 30" (762 mm) uncrated, with legs removed [All Models]



**THE MONTAGUE COMPANY**  
 1830 Stearman Avenue, Hayward, CA 94540  
 800 345-1830 • Fax: 510 785-3342  
 www.montaguecompany.com

Due to continuous product improvements, specifications are subject to change without notice.



HDS-3 [Rev. 01/10]