



LEGEND™ Heavy-Duty 36" (914mm) Gas Range

Item No. _____

Project _____

Quantity _____

(- 14) Top Series



Model 136-14

SHORT/BID SPECIFICATION

Range shall be a Montague **Legend** Model [Specify one]:

- 136-14**, with front-vented 40,000 BTU/hr conventional oven with counterweighted door, porcelainized steel interior, three-position rack guides and one wire pan rack standard
- V136-14**, with indirect-fired 45,000 BTU/hr convection oven with counterweighted door, porcelainized steel interior, five-position rack guides and three wire pan racks standard
- 36-14**, with open front cabinet base with two shelves;
- M36-14**, with 28" (711mm) high modular stand with stainless steel tubular legs;

...a 36" (914mm) wide heavy-duty gas-fired unit with one 18" (457mm) heavy-duty cast iron, precision-ground open top grate, over two 30,000 BTU/hr lift off star burners; and one 35,000 BTU/hr, 18" (457mm) wide (French style) hot top with ring and cover positioned at front of cast iron plate; provided with individual burner controls and automatic standing pilots; with stainless steel front and exterior bottom, black painted sides and back, 4" (102mm) high flue riser and 3" (76mm) deep front rail standard; plus all the features listed and options/accessories checked:

RANGE TOPSIDE FEATURES:

One 18" wide x 31" deep (457 x 787mm) open burner top positioned left with:

- Heavily ribbed cast iron, surface-ground top grate with:
- Two large-diameter 30,000 BTU/hr lift off star burners with raised ports
- Automatic, standing pilots
- Drip pan positioned under open burners

MODEL GUIDE		
✓ Model No.	Base Style/Type	-14 Range Top
136-14	With Standard Oven	
V136-14	With Convection Oven	
36-14	With Cabinet Base	
M36-14	With Modular Stand	

One 18" wide x 37" deep (457 x 787mm) French-type hot top positioned right with:

- Heavy-duty cast iron precision-ground plate
- Front-positioned removable ring & cover
- Front-fired, banjo-type 35,000 BTU/hr burner
- Heat transfer studs cast in plate bottom
- 2" (51mm) side and front flanges isolate heat under plate
- Insulating partition between top sections
- Sloped, brick-lined flues for better heat transfer

STANDARD (136-14 MODEL) OVEN FEATURES:

- 26" wide x 28" deep x 15" high (660 x 711 x 381mm) cooking compartment
- Accepts 18" x 26" (457 x 660mm) pans sideways or lengthwise
- Front-venting oven design for more even cooking
- Heavy-duty counterweighted oven door — no springs
- Three-position adjustable nickel-plated rack supports, with one rack standard
- Interior panels and door porcelain lined for long life & easy cleaning
- Low-to-500°F (260°C) thermostat mounted in insulated cool zone
- 40,000 BTU/hr cast iron burner with automatic ignition safety pilot

CONVECTION (V136-14 MODEL) OVEN FEATURES:

- 26" side x 22-1/4" deep x 15" high (660 x 565 x 381mm) cooking compartment
- Muffled, indirect-fired design with blower, for fast, even cooking
- Heavy duty counterweighted oven door — no springs
- Five-position adjustable nickel-plated rack supports, with three racks standard
- Interior panels and door porcelain lined for long life & easy cleaning
- Low-to-500°F (260°C) thermostat mounted in insulated cool zone
- 45,000 BTU/hr cast iron burner with automatic ignition safety pilot
- 6' (1829mm) cord with 3-prong plug (grounding NEMA 5-15P)

STANDARD CONSTRUCTION FEATURES:

- Satin finish stainless steel front and exterior bottom with 76mm deep front rail
- Other surfaces painted black with electrolytic zinc undercoating
- Stainless steel 4" (102mm) rear flue riser standard
- 6" (152mm) adjustable stainless steel legs standard (Except M36-14 Model)
- 28" (711mm) stainless steel tubular legs standard with M36-14 Model
- Cabinet base with sides, back panel and two shelves on 36-14 Model
- 1-1/4" NPT front gas manifold with 1/2 union on each end

AGENCY APPROVALS:

- NSF Listed
- ETL Design Certified to ANSI Z83.11 • CSA 1.8
- CE Approved • EN 203-1



HDS-38 [Rev. 1/12]

Item No. _____

Project _____

Quantity _____

LEGEND™ Heavy-Duty 36" (914mm) Gas Range

(-14) Top Series

Dimensions in brackets are millimeters

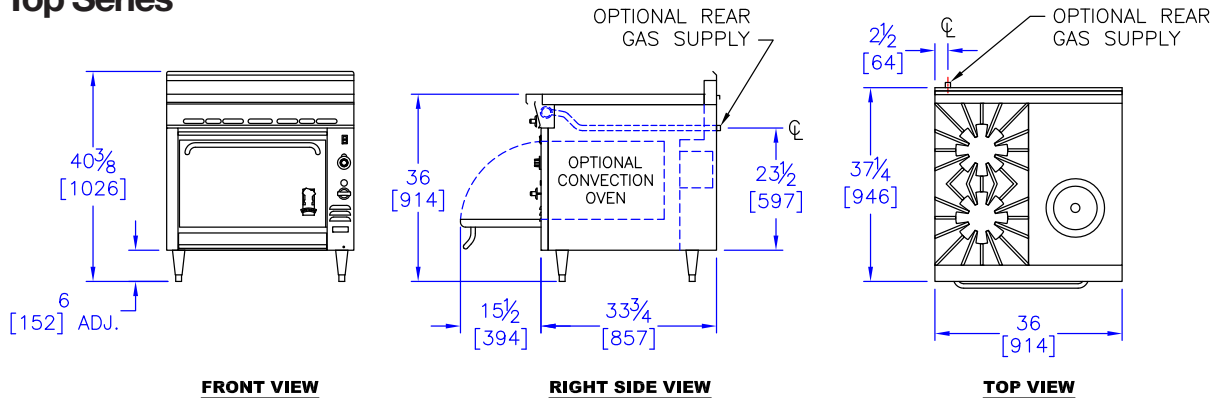

OPTIONS GUIDE:

Top Range:

- 42" (1067mm) range depth [Add Suffix: -40]
- 304 stainless steel burner box assembly

Oven:

- Cast iron oven bottom
- Extra oven racks: ____ ea.
- 650°F (343°C) finishing oven with cast iron oven bottom—includes cast iron oven bottom option [see Heavy Duty option page HDS-46]

Back Panels/Shelves:

- 18" (457mm) high back
- Single high shelf
- Double high shelf
- 6" (152mm) wide stainless steel plate shelf
- 8" (203mm) wide stainless steel plate shelf

Finish:

- Stainless steel left side panel
- Stainless steel right side panel
- Stainless steel back panel
- Stainless steel shelves and sides [36-14 Cabinet Model]

Special Finish: [Consult Factory]

Manifolds: [Left rear with pressure regulator]:

- 1" NPT up to 400,000 BTU/hr
- Manifold Cap:** left side right side

Stainless Manifold Cover:

- left side right side

Electrical (V136):

- 120 V, 1-phase, 60 Hz, 3.4 A (standard, with 6' (1.8m) NEMA 5-15P power cord)
- 208-240 V, 1-phase, 60 Hz, 1.7 A

Controls: [see Heavy Duty option page HDS-46]

- Electronic rangetop pilot ignition; electronic oven control (V136 & 136 ovens only)
- Flame failure rangetop safety valves
- Electronic rangetop pilot ignition & flame failure rangetop safety valves; electronic oven control (V136 & 136 ovens only)

General:

- Casters — set of four 5" (127mm) casters
- Flanged feet with holes

Flex Connector Kit [1"] NPT:

- 3' (914mm) 4' (1219mm)

Security Options/Prison Package

[Consult Factory]

International Approvals:

- CE - Conformance Européenne - EN203-1
- Includes flame failure valve option*
- Canadian Approval

INSTALLATION REQUIREMENTS & SHIPPING INFORMATION

- Ovens & ranges must be installed in accordance with local codes or in their absence with the National Fuel Gas Code: ANSI Z223.1; Natural Fuel Gas Code: CAN/CGA-B149.1 or Propane Installation Code: CAN/CGA-B149.2, as applicable. Compliance with codes is the responsibility of the Owner and Installer.
- An adequate ventilation system is required. Refer to National Fire Protection Association Standard No. 96, "Vapor Removal from Cooking Equipment."
- This appliance is intended for commercial use by professionally trained personnel. NOT intended for Residential Use.
- Specify installation elevation: _____ if above 2,000 ft (610m).
- GAS INLET SIZE (All Models):** 1-1/4" NPT front manifold with 1/2" union on each end provided for battery connection. A properly sized gas pressure regulator must be furnished by the Installer.
- The incoming gas line pressure into the regulator should be 8"-14" w.c. for natural gas, and 12"-14" w.c. for propane gas.

Minimum Clearances	Combustible Construction	Noncombustible Construction
From Back Wall*	2" (51mm)	0"
Left & Right Side	15" (381mm)	0"
With 6" (152mm) legs	Suitable for installation on combustible floors	
*V136 Models require 2" (51mm) for motor clearance at rear		

Specify Type of Gas:		<input type="checkbox"/> Natural	<input type="checkbox"/> Propane	Electrical	Shipping Weight	Shipping Class	Cube (Crated) ft ³ /m ³
Gas Delivery Pressure:		6.0" WC	10.0" WC	120V			
Models:	Burners	BTU/hr (kW)	BTU/hr (kW)	Amperage			
136-14	4	135,000 (39.6)	135,000 (39.6)	---	616 lbs (279 kg)	85	27/.75
V136-14	4	140,000 (41)	140,000 (41)	3.4	640 lbs (290 kg)	85	27/.75
36-14	3	95,000 (27.8)	95,000 (27.8)	---	430 lbs (195 kg)	85	27/.75
M36-14	3	95,000 (27.8)	95,000 (27.8)	---	360 lbs (163 kg)	85	13/.4

Entry Clearance: 30" (762mm) uncrated, with legs removed [All Models]



THE MONTAGUE COMPANY

1830 Stearman Avenue, Hayward, CA 94545

800 345-1830 • Fax: 510 785-3342

www.montaguecompany.com

Due to continuous product improvements, specifications are subject to change without notice.



HDS-38 [Rev. 1/12]