



LEGEND™

Heavy-Duty 36" (914mm) Gas Range

Item No. _____

Project _____

Quantity _____

(-13PL) Top Series



Model 136-13PL

SHORT/BID SPECIFICATION

Range shall be a Montague *Legend* Model [Specify one]:

- 136-13PL**, with front-vented 40,000 BTU/hr conventional oven with counterweighted door, porcelainized steel interior, three-position rack guides and one wire pan rack standard
- V136-13PL**, with indirect-fired 45,000 BTU/hr convection oven with counterweighted door, porcelainized steel interior, five-position rack guides and three wire pan racks standard
- 36-13PL**, with open front cabinet base with two shelves;
- M36-13PL**, with 28" (711mm) high modular stand with stainless steel tubular legs;

...a 36" (914mm) wide heavy-duty gas-fired unit with a 13" (330mm) wide Spanish-style plancha with raised 3/4" (19mm) thick precision-ground cook surface, full perimeter grease trough with drop to grease receptacle and one 15,000 BTU/hr burner; and one 18" (457mm) heavy-duty cast iron, precision-ground open top grate, over two 30,000 BTU/hr lift off star burners, each provided with individual burner controls and automatic standing pilots; with stainless steel front and exterior bottom, black painted sides and back, 4" (102mm) high flue riser and 3" (76mm) deep front rail standard; plus all the features listed and options/accessories checked:

RANGE TOP FEATURES:

One 13" wide x 25" deep (330mm x 635mm) Plancha [Spanish griddle] top, positioned left, with:

- Full perimeter grease trough
- Two-quart hanging grease receptacle
- One 15,000 BTU/hr gas burner with standing pilot & gas control valve

One 18" wide x 31" deep (457mm x 787mm) open burner top with:

- Heavily ribbed cast iron, surface-ground top grate positioned right
- Two large-diameter 30,000 BTU/hr lift off star burners with raised ports
- Automatic, standing pilots
- Drip pan positioned under burners

MODEL GUIDE		
Model No.	Base Style/Type	-13PL Range Top
136-13PL	With Standard Oven	
V136-13PL	With Convection Oven	
36-13PL	With Cabinet Base	
M36-13PL	With Modular Stand	

STANDARD (136-13PL MODEL) OVEN FEATURES:

- 26" wide x 28" deep x 15" high (660mm x 711mm x 381mm) cooking compartment
- Accepts 18" x 25" (457mm x 660mm) pans sideways or lengthwise
- Front-venting oven design for more even cooking
- Heavy-duty counterweighted oven door — no springs
- Three-position adjustable nickel-plated rack supports, with one rack standard
- Interior panels and door porcelain-lined for long life & easy cleaning
- Low-to-500°F (260°C) thermostat mounted in insulated cool zone
- 40,000 BTU/hr cast iron burner with automatic ignition safety pilot

CONVECTION (V136-13PL MODEL) OVEN FEATURES:

- 26" wide x 22-1/4" deep x 15" high (660mm x 565mm x 381mm) cooking compartment
- Muffled, indirect-fired design with blower, for fast, even cooking
- Heavy-duty counterweighted oven door — no springs
- Five-position adjustable nickel-plated rack supports, with three racks standard
- Interior panels and door porcelain lined for long life & easy cleaning
- Low-to-500°F (260°C) thermostat mounted in insulated cool zone
- 45,000 BTU/hr cast iron burner with automatic ignition safety pilot

STANDARD CONSTRUCTION FEATURES:

- Satin finish stainless steel front with 3" (76mm) deep front rail
- Other surfaces painted black with electrolytic zinc undercoating
- Stainless steel 4" (102mm) rear flue riser standard
- 6" (152mm) adjustable stainless steel legs standard (Except M36-13PL Model)
- 28" (711mm) stainless steel tubular legs standard with M36-13PL Model
- Cabinet base with sides, back panel and two shelves on 36-13PL Model
- 1-1/4" NPT front gas manifold with 1/2 union on each end

STANDARD WARRANTY:

- One Year, Parts & Labor
- Lifetime Warranty on Oven Door

AGENCY APPROVALS

- NSF Listed
- ETL Design Certified to ANSI Z83.11



HDS-28 [Rev. 01/10]

Item No. _____

Project _____

Quantity _____

LEGEND™ Heavy-Duty 36" (914mm) Gas Range

(-13PL) Top Series

Dimensions in brackets are millimeters

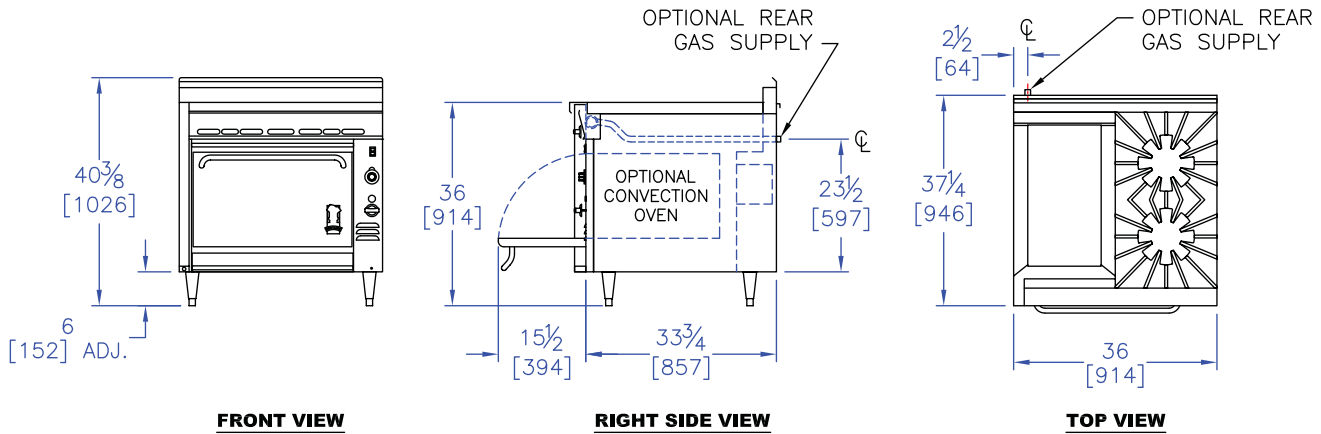

OPTIONS GUIDE:

Top Range:

- 42" (1067mm) range depth [Add Suffix: -40]
- 304 stainless steel burner box assembly

13" (330mm) Plancha:

- 20,000 BTU/hr burner with 550°F (288°C) thermostat
- 1" (25mm) thick plate
- Polished chrome-plated cooking surface (requires thermostat)

Oven:

- Cast iron oven bottom
- Extra oven racks: ____ ea.

Back Panels/Shelves:

- 18" (457 mm) high back
- Single high shelf
- Double high shelf
- 6" (152 mm) wide stainless steel plate shelf
- 8" (203 mm) wide stainless steel plate shelf

Manifolds: [Left rear with pressure regulator]:

- 1" NPT up to 400,000 BTU/hr
- Manifold Cap:** left side right side
- Stainless Manifold Cover:** left side right side

Finish:

- Stainless steel left side panel
- Stainless steel right side panel
- Stainless steel back panel
- Stainless steel exterior bottom
- Stainless steel shelves and sides [36-12E Cabinet Model]

General:

- Casters — set of four 5" (127 mm) casters
- Flex Connector Kit** [1"] NPT:
 - 3' (914 mm) 4' (1219 mm)
- Security Options/Prison Package** [Consult Factory]

INSTALLATION REQUIREMENTS & SHIPPING INFORMATION

1. Ovens & ranges must be installed in accordance with local codes or in their absence with the National Fuel Gas Code: ANSI Z223.1; Natural Fuel Gas Code: CAN/CGA-B149.1 or Propane Installation Code: CAN/CGA-B149.2, as applicable. Compliance with codes is the responsibility of the Owner and Installer.
2. An adequate ventilation system is required. Refer to National Fire Protection Association Standard No. 96, "Vapor Removal from Cooking Equipment."
3. This appliance is intended for commercial use by professionally trained personnel. NOT intended for Residential Use.
4. Specify installation elevation: _____ if above 2,000 ft (610m).
5. GAS INLET SIZE (All Models): 1-1/4 NPT front manifold with 1/2 union on each end provided for battery connection. A properly sized gas pressure regulator must be furnished by the Installer.
6. The incoming gas line pressure into the regulator should be 8"-14" w.c. for natural gas, and 12"-14" w.c. for propane gas.

Minimum Clearances	Combustible Construction	Noncombustible Construction
From Back Wall*	2" (51 mm)	0"
Left & Right Side	15" (381 mm)	0"
With 6" (152mm) legs	Suitable for installation on combustible floors	
*V136 Models require 2" (51mm) for motor clearance at rear		

Specify Type of Gas:		<input type="checkbox"/> Natural	<input type="checkbox"/> Propane	Shipping Weight	Shipping Class	Cube (Crated) ft ³ /m ³
Gas Delivery Pressure:		6.0" WC	10.0" WC			
Models:	Burners	BTU/hr* (kW)	BTU/hr* (kW)			
136-13PL	4	115,000 (33.7)	115,000 (33.7)	636 lbs (288 kg)	85	32/.9
V136-13PL	4	120,000 (35.2)	120,000 (35.2)	660 lbs (299 kg)	85	32/.9
36-13PL	3	75,000 (22)	75,000 (22)	450 lbs (204 kg)	85	32/.9
M36-13PL	3	75,000 (22)	75,000 (22)	390 lbs (177 kg)	85	18/.5

*Add 5,000 BTU/hr (1.5 kW) for thermostatically controlled plancha burner.

Entry Clearance: 30" (762mm) uncrated, with legs removed [All Models]

Due to continuous product improvements, specifications are subject to change without notice.



THE MONTAGUE COMPANY
 1830 Stearman Avenue, Hayward, CA 94545
 800 345-1830 • Fax: 510 785-3342
www.montaguecompany.com



HDS-28 [Rev. 01/10]