



LEGEND™

Heavy-Duty 36" (914mm) Gas Range

Item No. _____

Project _____

Quantity _____

(- 12) Top Series



Model 136-12

SHORT/BID SPECIFICATION

Range shall be a Montague **Legend** Model [Specify one]:

- 136-12**, with front-vented 40,000 BTU/hr conventional oven with counterweighted door, porcelainized steel interior, three-position rack guides and one wire pan rack standard
- V136-12**, with indirect-fired 45,000 BTU/hr convection oven with counterweighted door, porcelainized steel interior, five-position rack guides and three wire pan racks standard
- 36-12**, with open front cabinet base with two shelves;
- M36-12**, with 28" (711mm) high modular stand with stainless steel tubular legs;

...a 36" (914mm) wide heavy-duty gas-fired unit with a 18" (457mm) wide griddle with 3/4" (19mm) thick precision-ground cook surface, 4" (102mm) high splash, 2-5/8" (67mm) wide front grease trough with drop to grease receptacle and two 15,000 BTU/hr burners; and one 35,000 BTU/hr, 18" (457mm) wide (French style) hot top with ring and cover positioned at front of cast iron plate, each provided with individual burner controls and automatic standing pilots; with stainless steel front and exterior bottom, black painted sides and back, 4" (102mm) high flue riser and 3" (76mm) deep front rail standard; plus all the features listed and options/accessories checked:

RANGE TOP FEATURES:

One 18" wide x 28" deep (457mm x 711mm) griddle, positioned left, with

- 3/4" (19mm) thick precision-ground steel cook surface
- 4" (102mm) high backsplash and tapered side-splashes
- 2-5/8" (67mm) wide grease trough pitched to grease receptacle
- Built-in 2-1/8" (54mm) hanging grease receptacle
- Two 15,000 BTU/hr gas burners with standing pilots & gas control valves
- Adjusting bolts for changing griddle forward pitch

| MODEL GUIDE | | | |
|-------------|----------------------|---------------|--|
| Model No. | Base Style/Type | -12 Range Top | |
| 136-12 | With Standard Oven | | |
| V136-12 | With Convection Oven | | |
| 36-12 | With Cabinet Base | | |
| M36-12 | With Modular Stand | | |

One 18" wide x 31" deep (457mm x 787mm) French-style Hot Top positioned right with:

- Heavy-duty cast iron precision-ground plate
- Front-positioned removable ring & cover
- Front-fired, banjo-type 35,000 BTU/hr burner
- Heat transfer studs cast in plate bottom
- 2" (51mm) side and front flanges isolate heat under plate
- Insulating partition between top sections
- Sloped, brick-lined flues for better heat transfer

STANDARD (136-12 MODEL) OVEN FEATURES:

- 26" wide x 28" deep x 15" high (660mm x 711mm x 381mm) cooking compartment
- Accepts 28" x 36" (457mm x 660mm) pans sideways or lengthwise
- Front-venting oven design for more even cooking
- Heavy-duty counterweighted oven door — no springs
- Three-position adjustable nickel-plated rack supports, with one rack standard
- Interior panels and door porcelain-lined for long life & easy cleaning
- Low-to-500°F (260°C) thermostat mounted in insulated cool zone
- 40,000 BTU/hr cast iron burner with automatic ignition safety pilot

CONVECTION (V136-12 MODEL) OVEN FEATURES:

- 26" wide x 22-1/4" x 15" high (660mm x 565mm x 381mm) cooking compartment
- Muffled, indirect fired design with blower, for fast, even cooking
- Heavy duty counterweighted oven door — no springs
- Five-position adjustable nickel-plated rack supports, with three racks standard
- Interior panels and door porcelain lined for long life & easy cleaning
- Low-to-500°F (260°C) thermostat mounted in insulated cool zone
- 45,000 BTU/hr cast iron burner with automatic ignition safety pilot

STANDARD CONSTRUCTION FEATURES:

- Satin finish stainless steel front with 3" (76mm) deep front rail
- Other surfaces painted black with electrolytic zinc undercoating
- Stainless steel 4" (102mm) rear flue riser standard
- 6" (152mm) adjustable stainless steel legs standard (Except M36-12 Model)
- 28" (711mm) stainless steel tubular legs standard with M36-12 Model
- Cabinet base with sides, back panel and two shelves on 36-12 Model
- 1-1/4" NPT front gas manifold with 1/2 union on each end

STANDARD WARRANTY:

- One Year, Parts & Labor
- Lifetime Warranty on Oven Door

AGENCY APPROVALS

- NSF Listed
- ETL Design Certified to ANSI Z83.11



HDS-23 [Rev. 01/10]

Item No. _____

Project _____

Quantity _____

LEGEND™ Heavy-Duty 36" (914mm) Gas Range

(-12) Top Series

Dimensions in brackets are millimeters

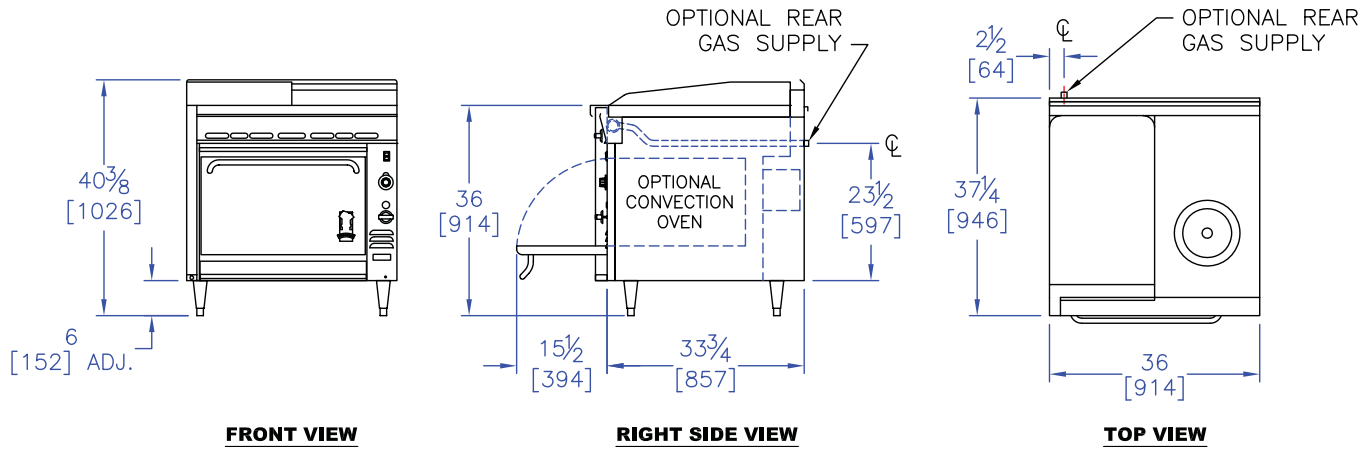

OPTIONS GUIDE:

Top Range:

- 42" (1067mm) range depth [Add Suffix: -40]

18" (457mm) Griddle:

- 450°F (232°C) Thermostatic Control [-T Suffix]
- 1" (25mm) thick griddle plate
- 1" (25mm) thick grooved griddle plate
- 34" (864mm) deep plate [Add Suffix -40]

Back Panels/Shelves:

- 18" (457 mm) high back
- Single high shelf
- Double high shelf
- 6" (152 mm) wide stainless steel plate shelf
- 8" (203 mm) wide stainless steel plate shelf

Oven:

- Cast iron oven bottom
- Extra oven racks: _____ea.

Manifolds: [Left rear with pressure regulator]:

- 1" NPT up to 400,000 BTU/hr
- Manifold Cap:** left side right side
- Stainless Manifold Cover:** left side right side

Finish:

- Stainless steel left side panel
- Stainless steel right side panel
- Stainless steel back panel
- Stainless steel exterior bottom
- Stainless steel shelves and sides [36-12 Cabinet Model]

General:

- Casters — set of four 5" (127 mm) casters
- Flex Connector Kit** [1"] NPT: 3' (914 mm) 4' (1219 mm)
- Security Options/Prison Package** [Consult Factory]

INSTALLATION REQUIREMENTS & SHIPPING INFORMATION

- Ovens & ranges must be installed in accordance with local codes or in their absence with the National Fuel Gas Code: ANSI Z223.1; Natural Fuel Gas Code: CAN/CGA-B149.1 or Propane Installation Code: CAN/CGA-B149.2, as applicable. Compliance with codes is the responsibility of the Owner and Installer.
- An adequate ventilation system is required. Refer to National Fire Protection Association Standard No. 96, "Vapor Removal from Cooking Equipment."
- This appliance is intended for commercial use by professionally trained personnel. NOT intended for Residential Use.
- Specify installation elevation: _____ if above 2,000 ft (610m).
- GAS INLET SIZE (All Models):** 1-1/4" NPT front manifold with 1/2" union on each end provided for battery connection. A properly sized gas pressure regulator must be furnished by the Installer.
- The incoming gas line pressure into the regulator should be 8"-14" w.c. for natural gas, and 12"-14" w.c. for propane gas.

| Minimum Clearances | Combustible Construction | Noncombustible Construction |
|--|---|-----------------------------|
| From Back Wall* | 2" (51 mm) | 0" |
| Left & Right Side | 6" (152 mm) | 0" |
| With 6" (152 mm) legs | Suitable for installation on combustible floors | |
| *V136 Models require 2" (51mm) for motor clearance at rear | | |

| Specify Type of Gas: | | <input type="checkbox"/> Natural | <input type="checkbox"/> Propane | Shipping Weight | Shipping Class | Cube (Crated) ft ³ /m ³ |
|------------------------|---------|----------------------------------|----------------------------------|------------------|----------------|---|
| Gas Delivery Pressure: | | 6.0" WC | 10.0" WC | | | |
| Models: | Burners | BTU/hr* (kW) | BTU/hr* (kW) | | | |
| 136-12 | 4 | 105,000 (30.8) | 105,000 (30.8) | 636 lbs (288 kg) | 85 | 32/.9 |
| V136-12 | 4 | 110,000 (32.2) | 110,000 (32.2) | 660 lbs (299 kg) | 85 | 32/.9 |
| 36-12 | 3 | 65,000 (19.1) | 65,000 (19.1) | 450 lbs (204 kg) | 85 | 32/.9 |
| M36-12 | 3 | 65,000 (19.1) | 65,000 (19.1) | 390 lbs (177 kg) | 85 | 18/.5 |

*For thermostatically controlled fry top add 10,000 BTU/hr (2.93) total kW.

Entry Clearance: 30" (762mm) uncrated, with legs removed [All Models]

Due to continuous product improvements, specifications are subject to change without notice.



THE MONTAGUE COMPANY
 1830 Stearman Avenue, Hayward, CA 94540
 800 345-1830 • Fax: 510 785-3342
 www.montaguecompany.com



HDS-23 [Rev. 01/10]